

10

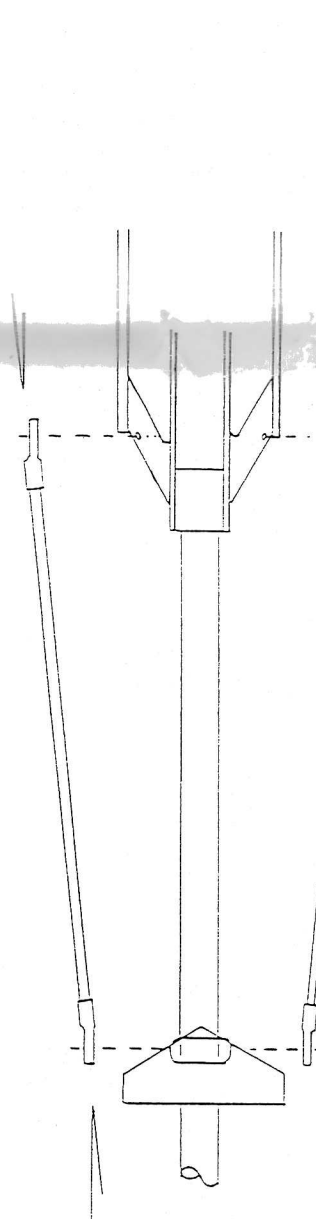

10

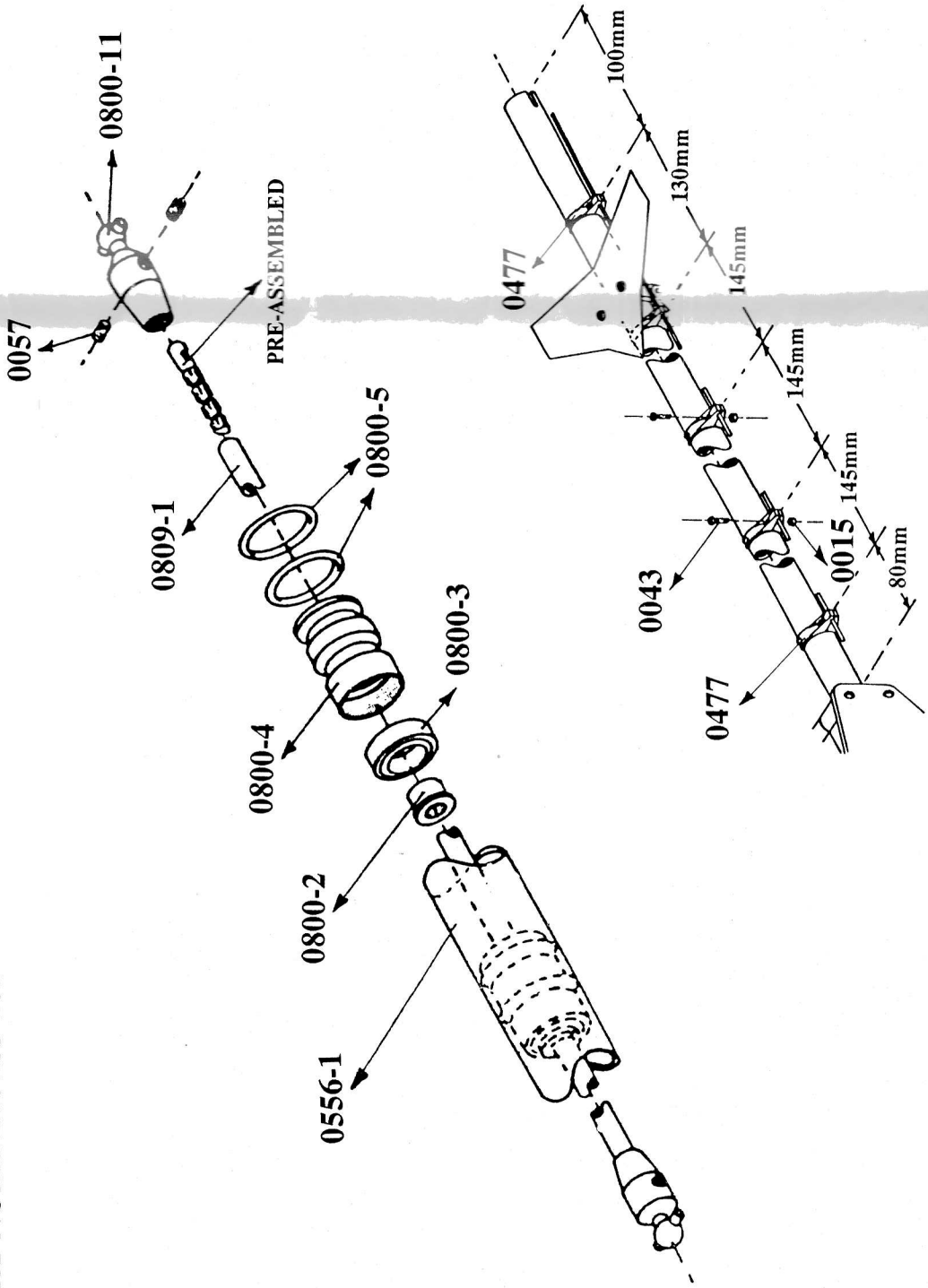
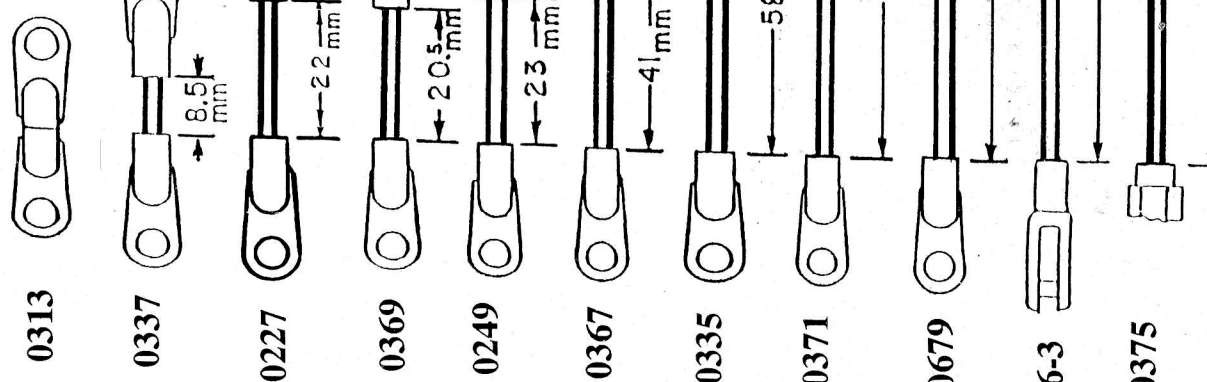
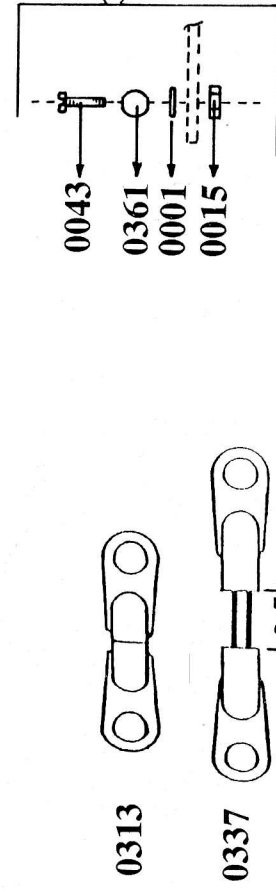
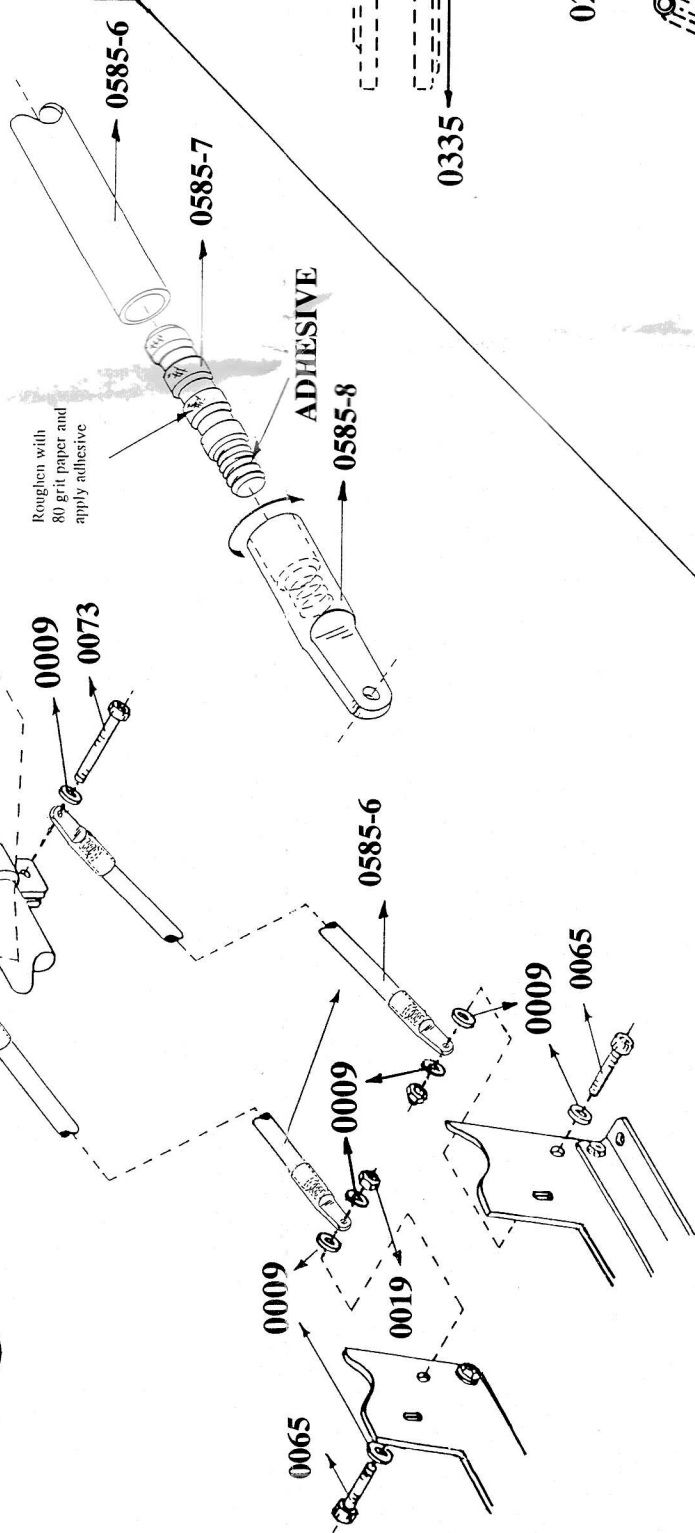

* Variable with servo choice and position.

11

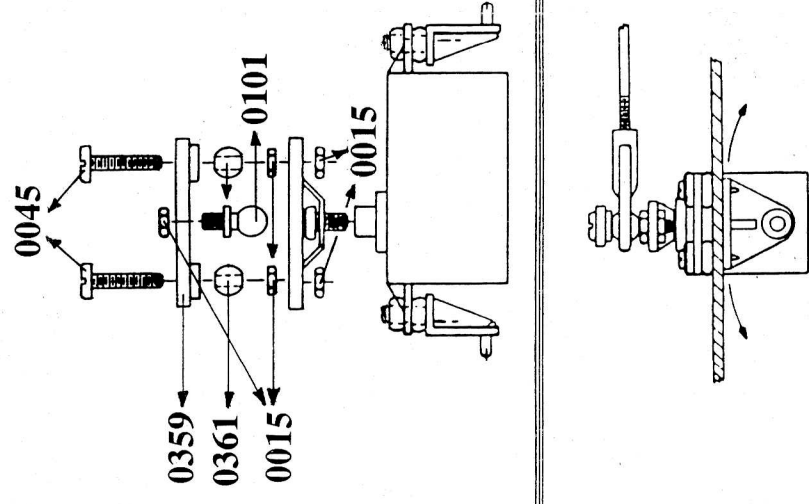

* Variable with servo choice and position.

12

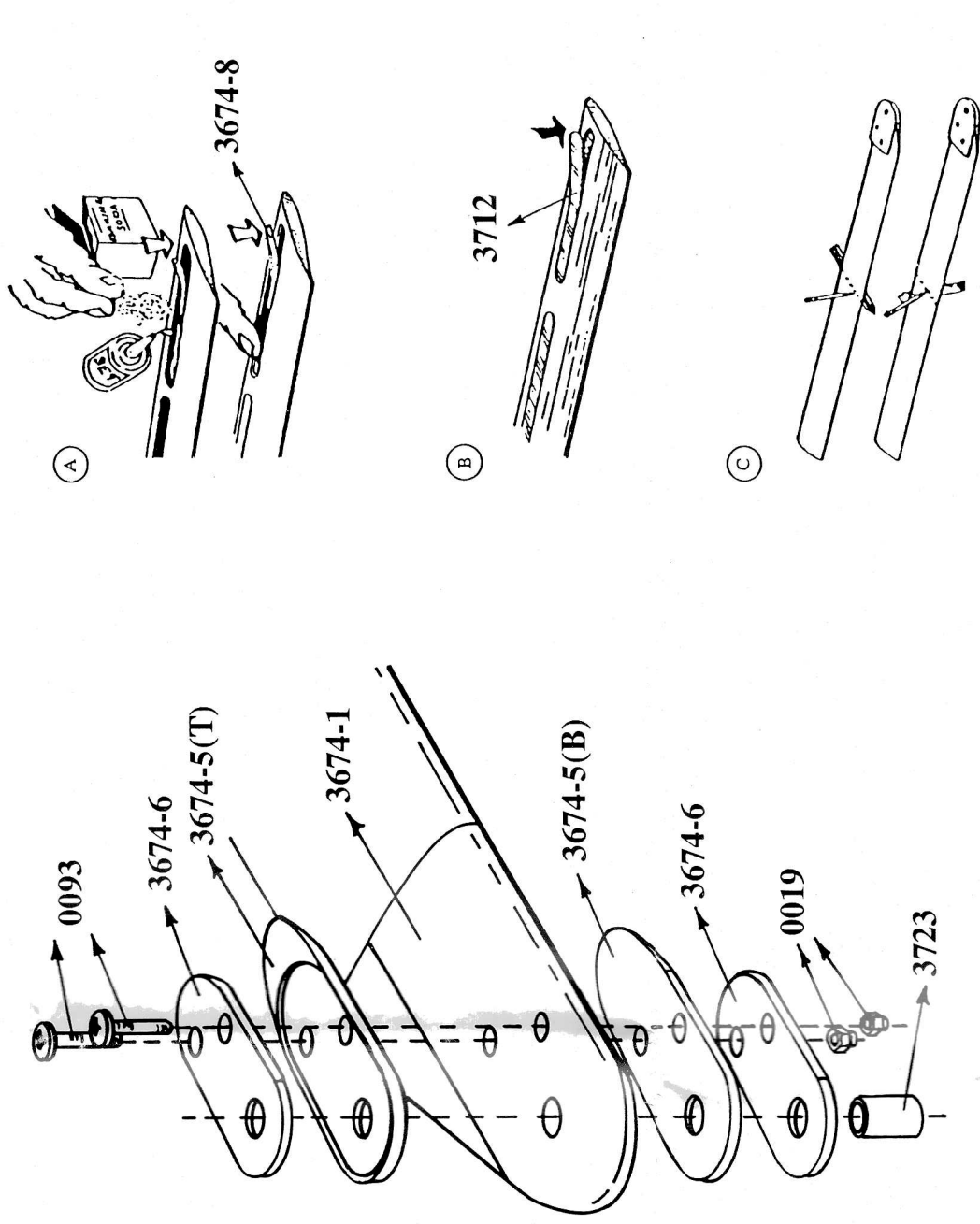
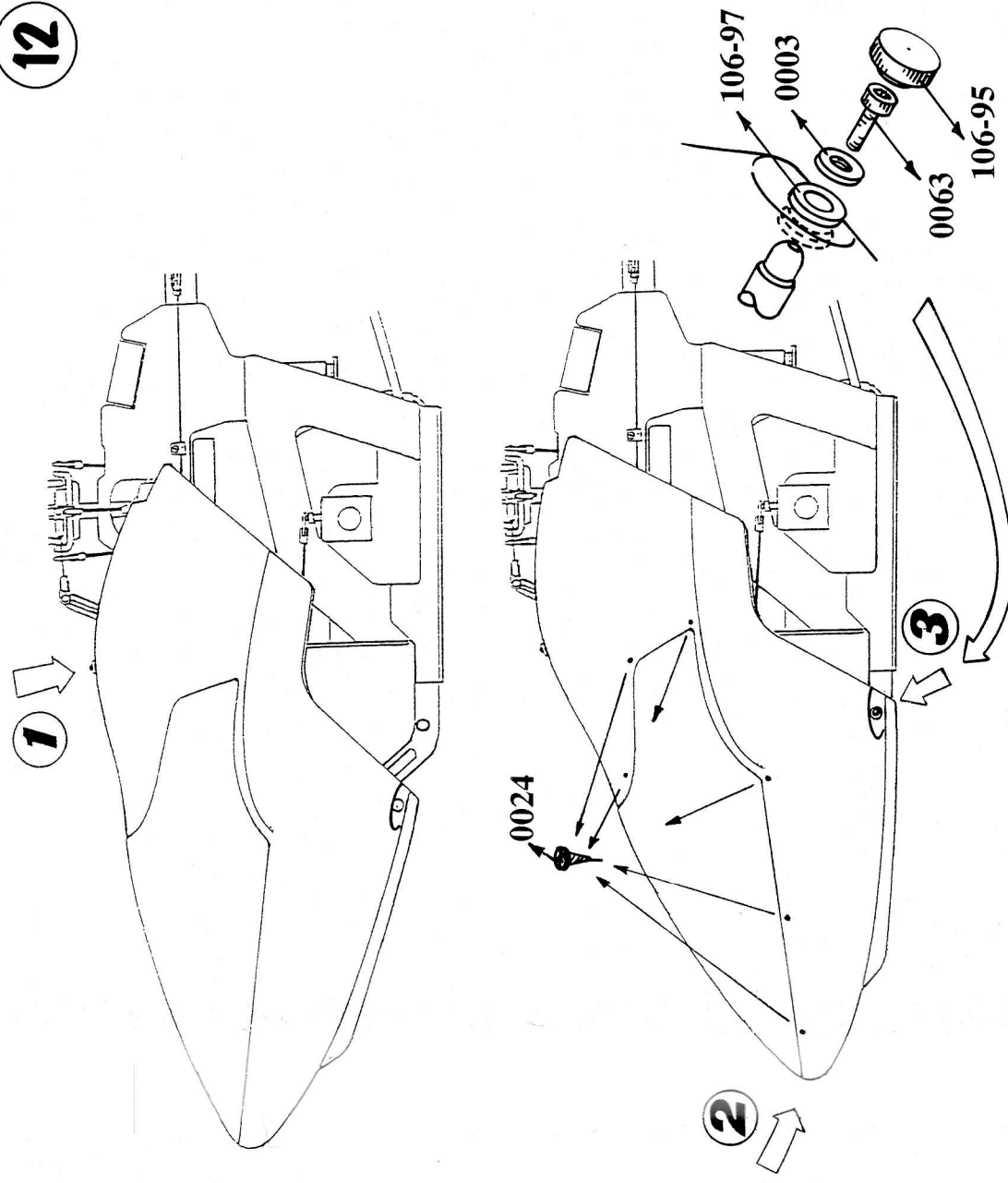

13

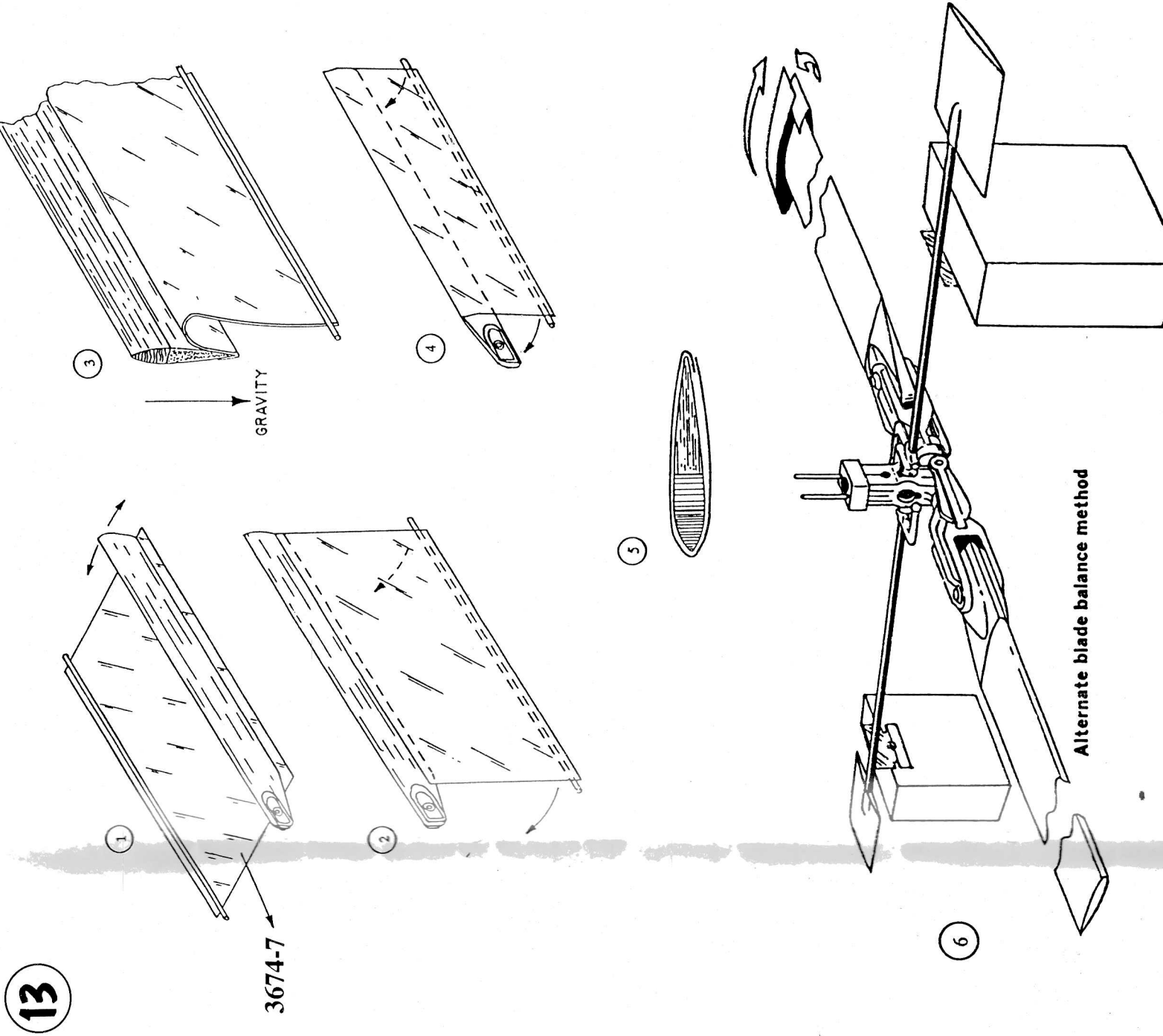

Alternate blade balance method

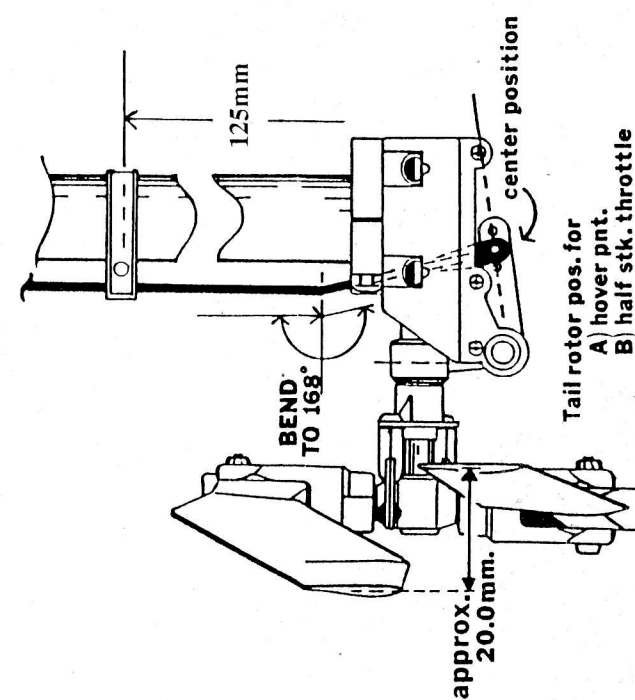
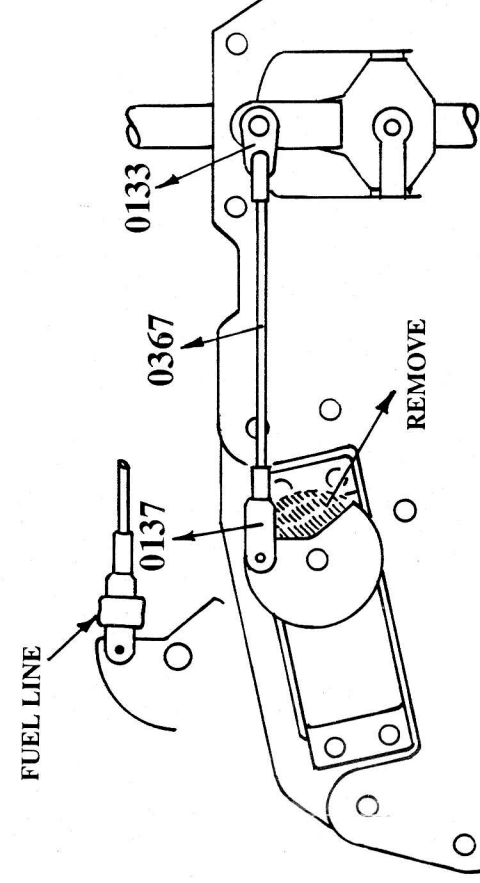
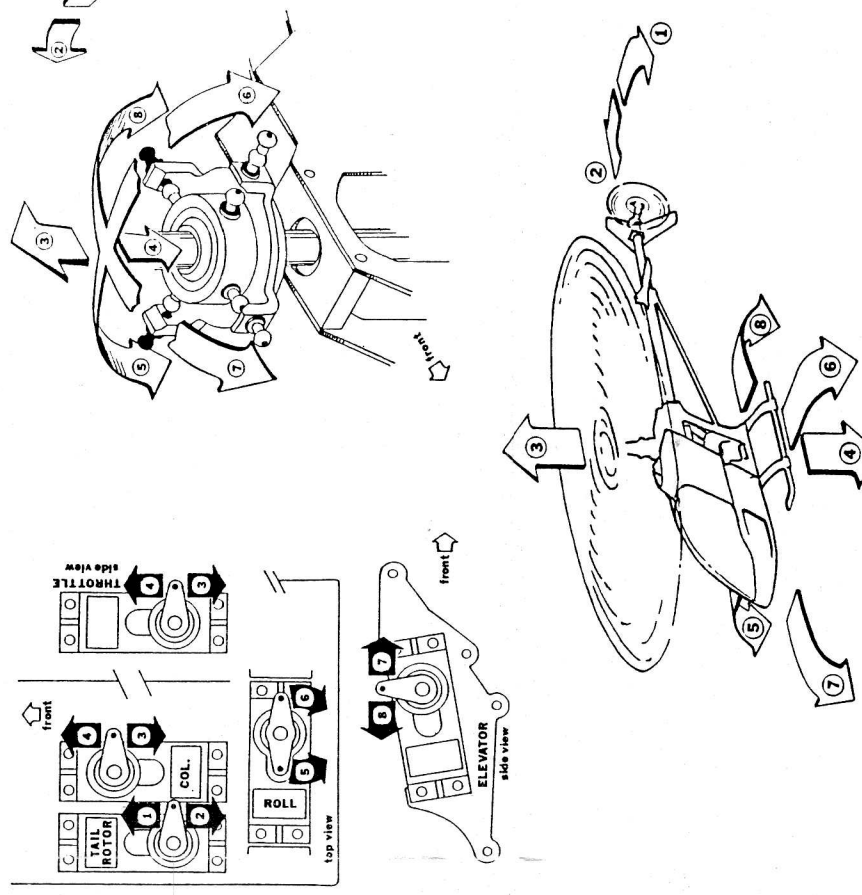
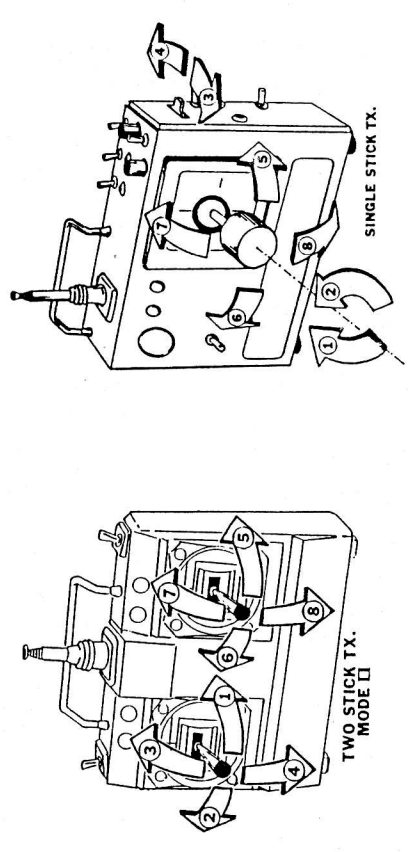
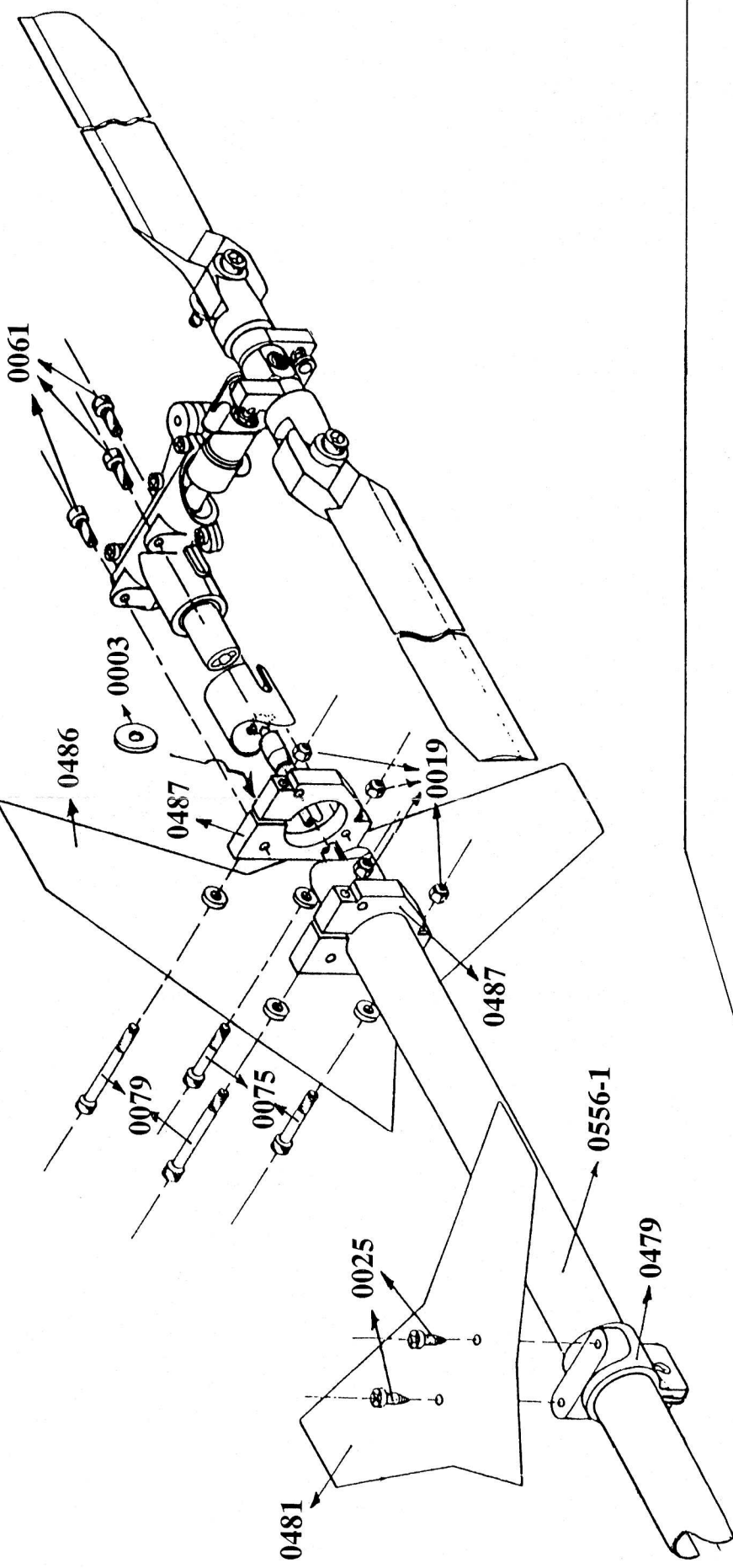

Tail rotor pos. for
A) lower pos.
B) center
C) A.T.S. on
D) neutral servo

* Variable with servo choice and position.