

組み立て説明書 ASSEMBLING INSTRUCTION

**FOR EXPORT**

# FALCON 707

ファルコン



主ローター直径	1,450mm
テールローター直径	280mm
胴体長	1,340mm
全備重量	3,700g
エンジン	49~50クラス
無線機	4ch

Main rotor dia.	57-2/25"
Tail rotor dia.	11-1/50"
Fuselage	52-3/4"
Full-equipped weight	8-4/25lbs.
Engine	49 - 50 class
Radio	4 channels

**ASSEMBLING SECTION**

**(1). Assembling DRIVE SECTION**

Symbol of screws  
 CS: Cap screw  
 SS: Set screw  
 PH: Pan head machine screw  
 TS: Tapping screw  
 FW: Flat washer  
 Brg.: Bearing

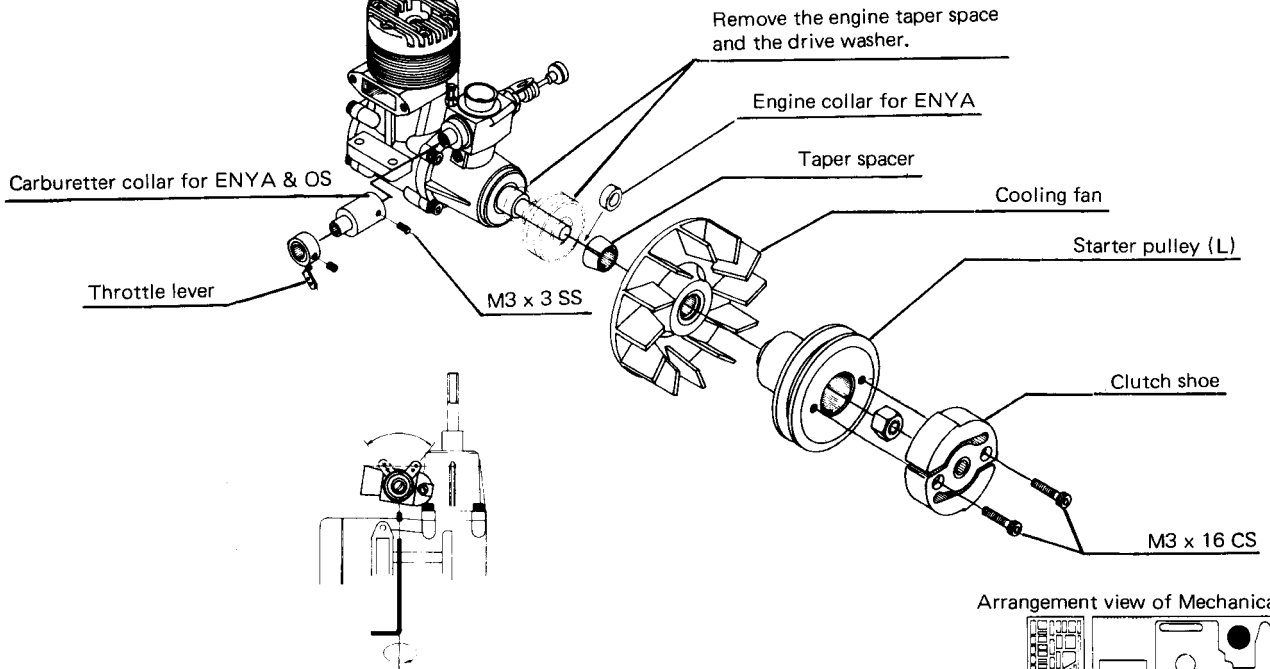

Arrangement view of Mechanical Cases

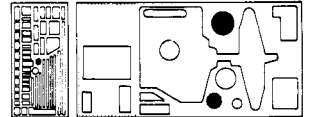

**(2). Mounting TAIL HOLDER**

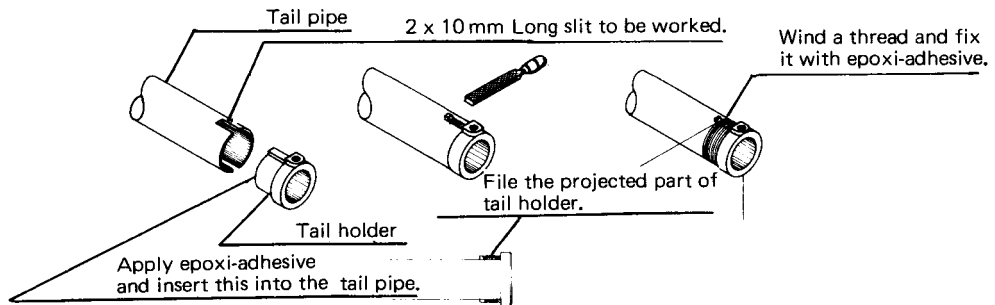

Mounting method of tail drive pipe

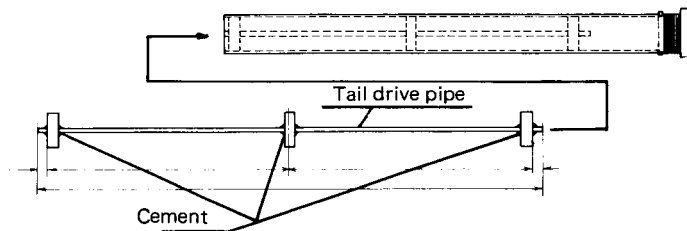

**(3). Assembling MAIN MISSION (Pre-assembled)**

**FOR 505**

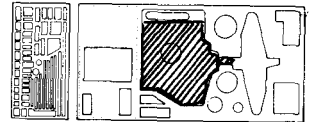
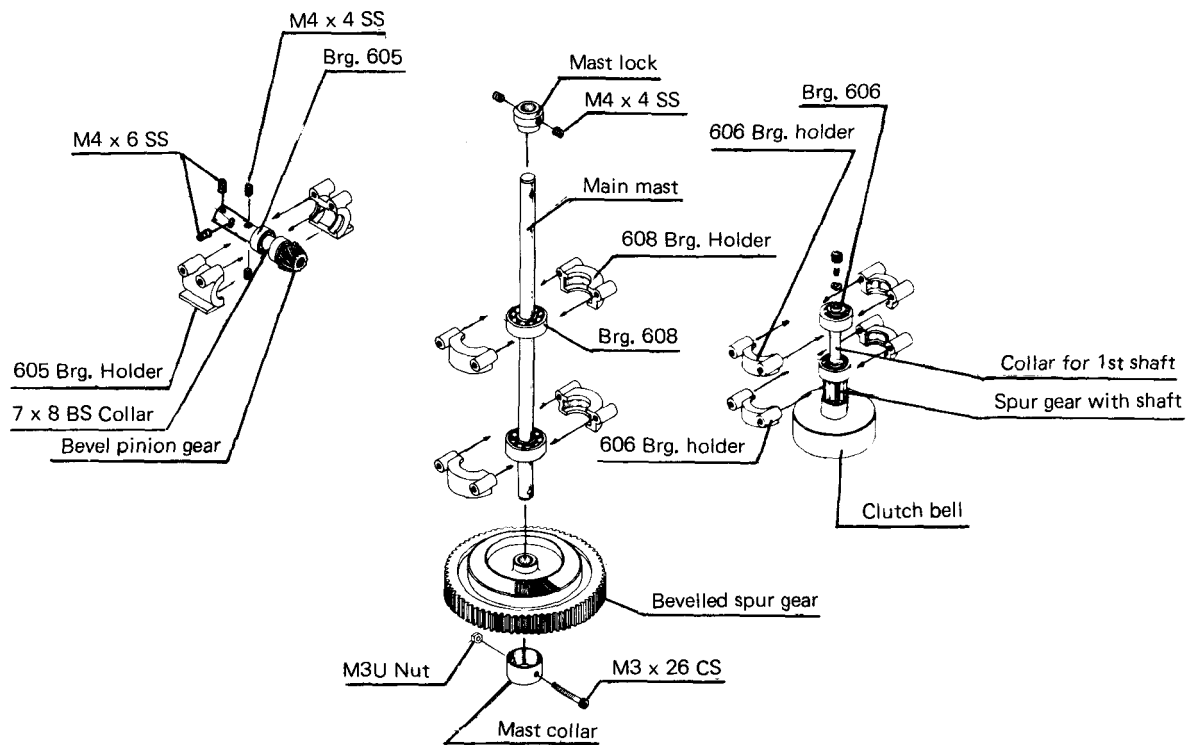

**(4). Assembling MAIN MISSION**

**FOR 707**

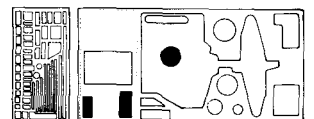
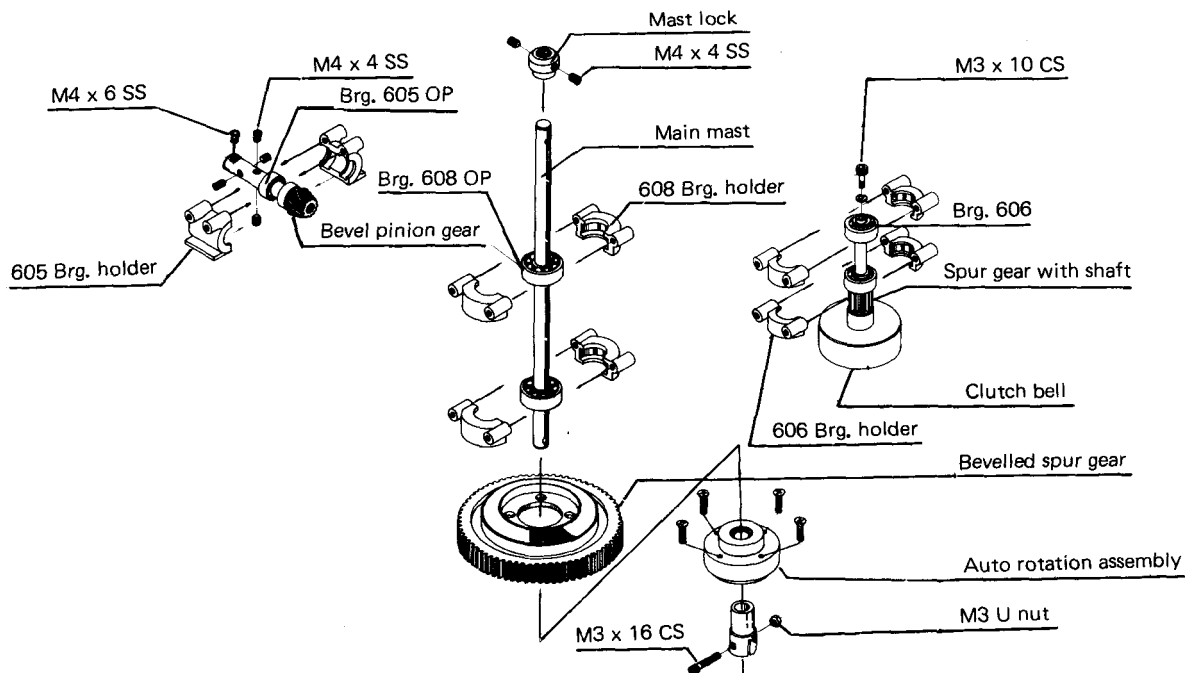

# (5). Assembling ROTOR HEAD

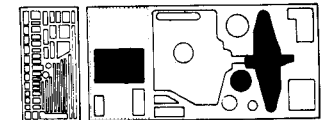
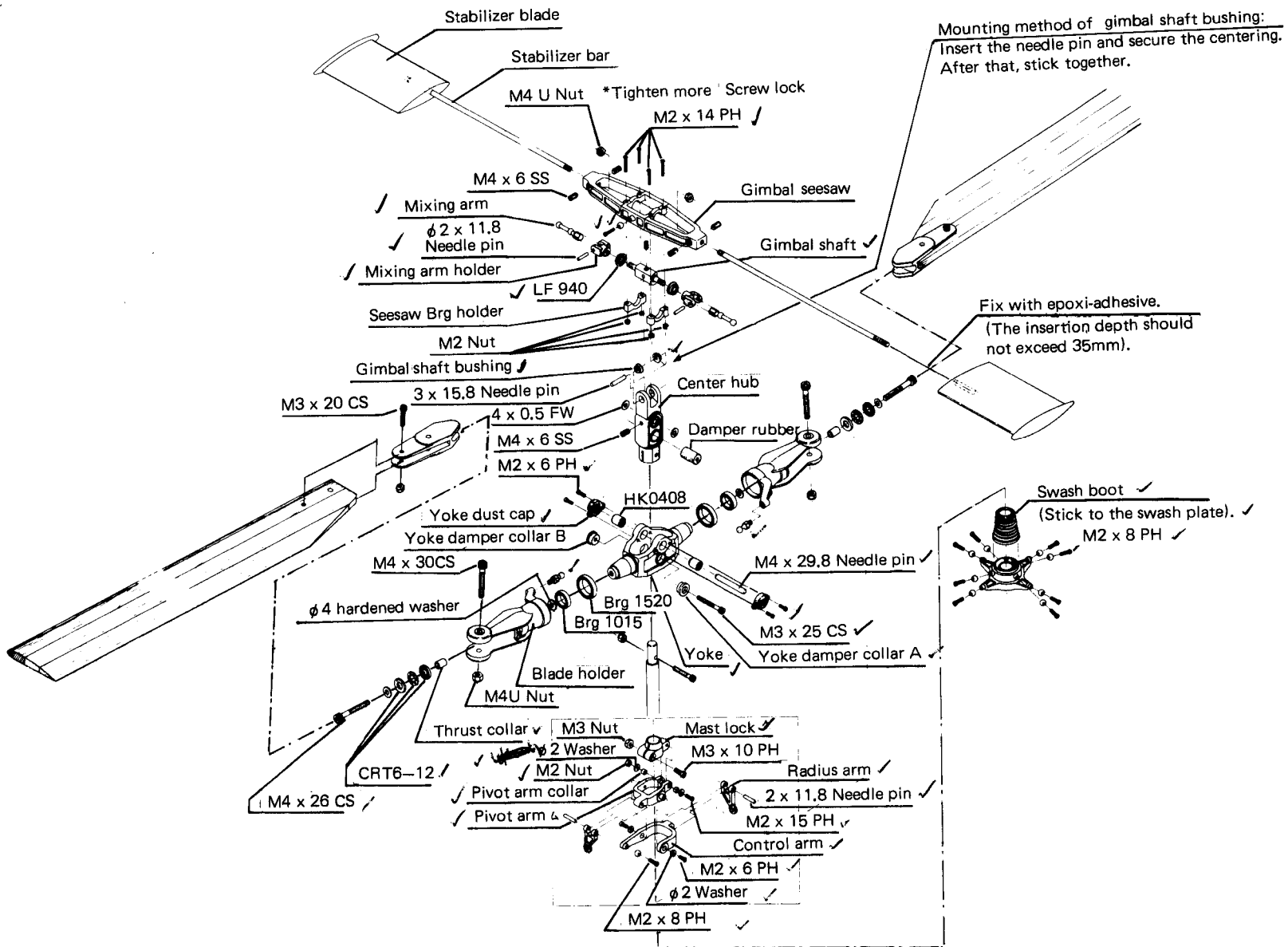

- 3 (K) -

(6). Assembled View of ROTOR HEAD

FOR 50F

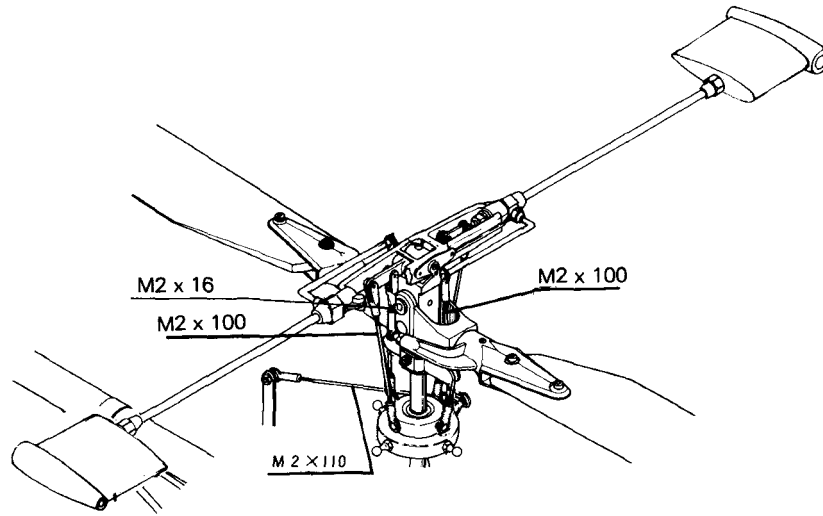

FOR 707

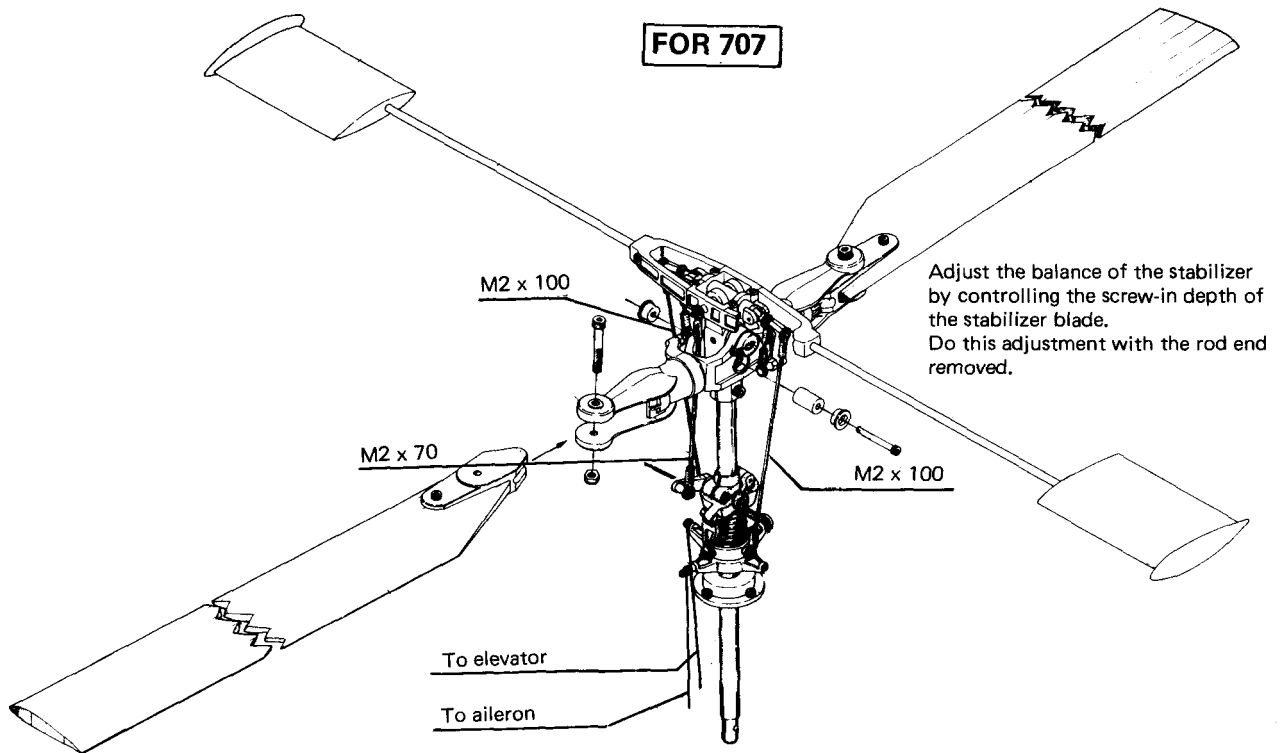

(7). Assembling TAIL MISSION

- 5 (U), (K) -

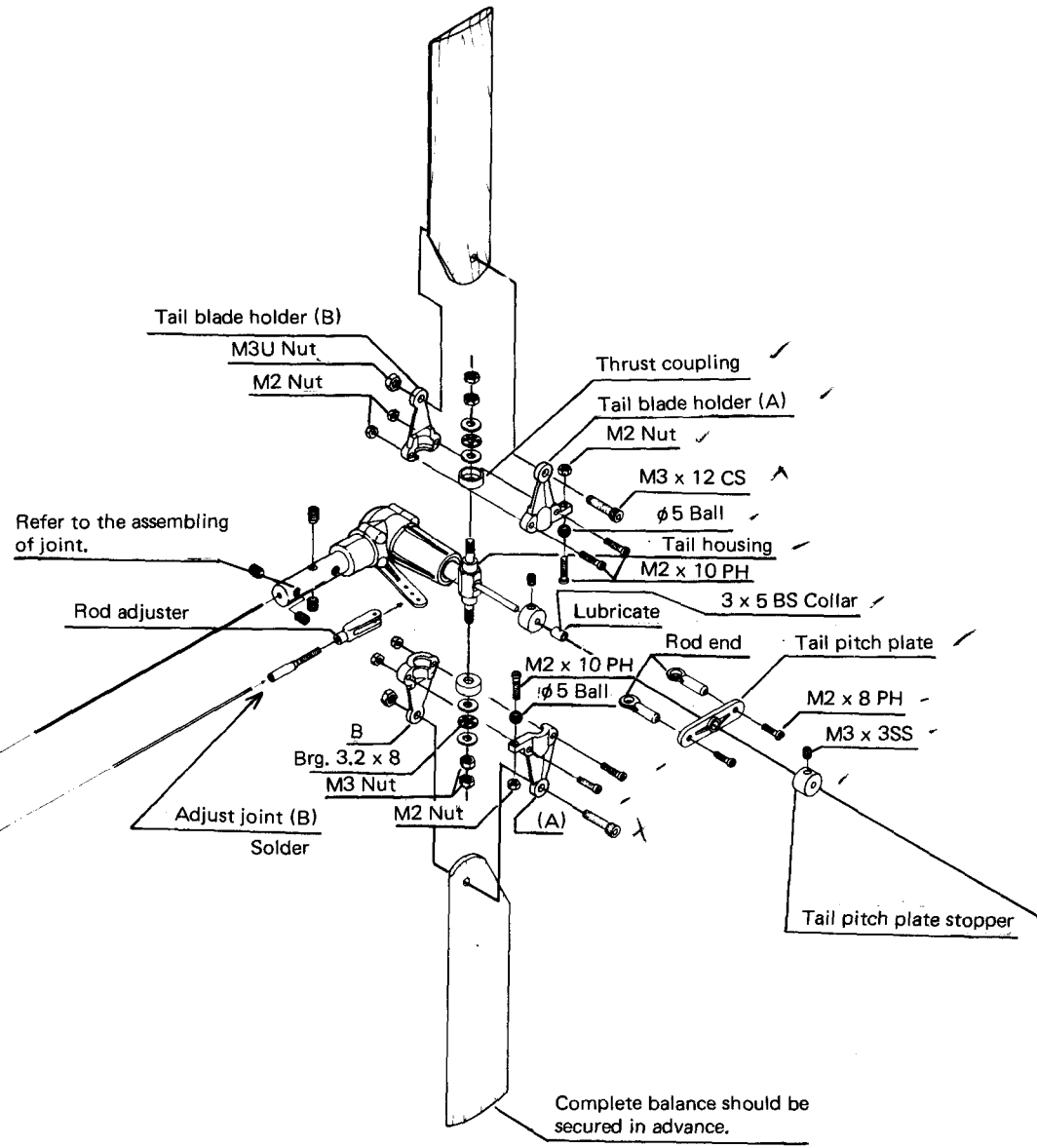

OPTION PARTS

W-type tail blade holder set

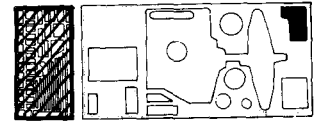
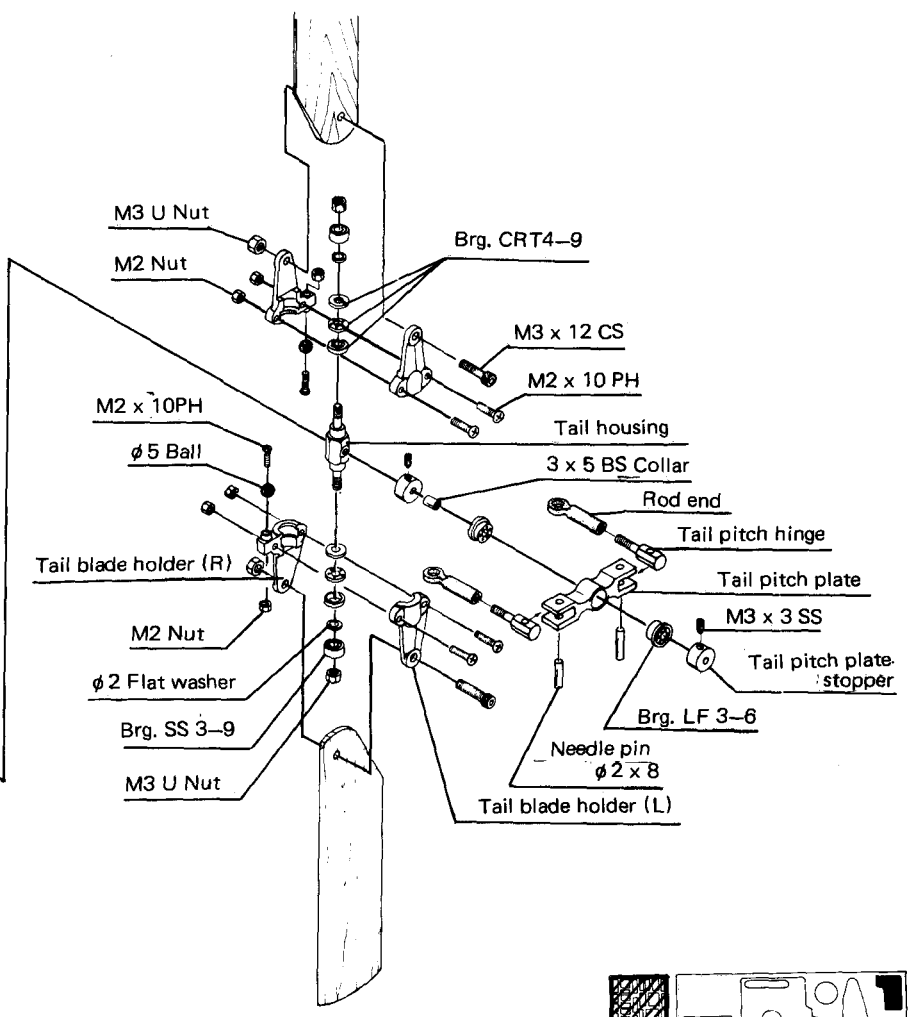

**(8). Assembling PITCH UP SECTION**

**FOR 505**

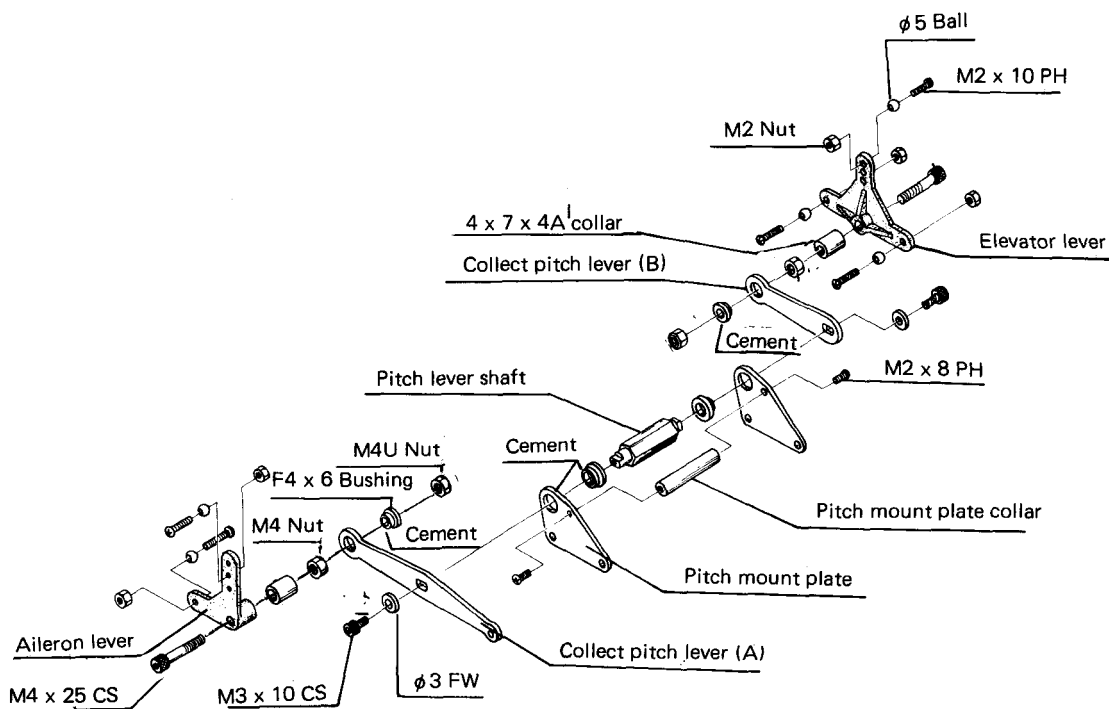

**FOR 707**

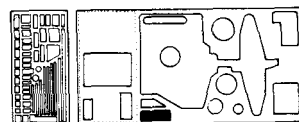
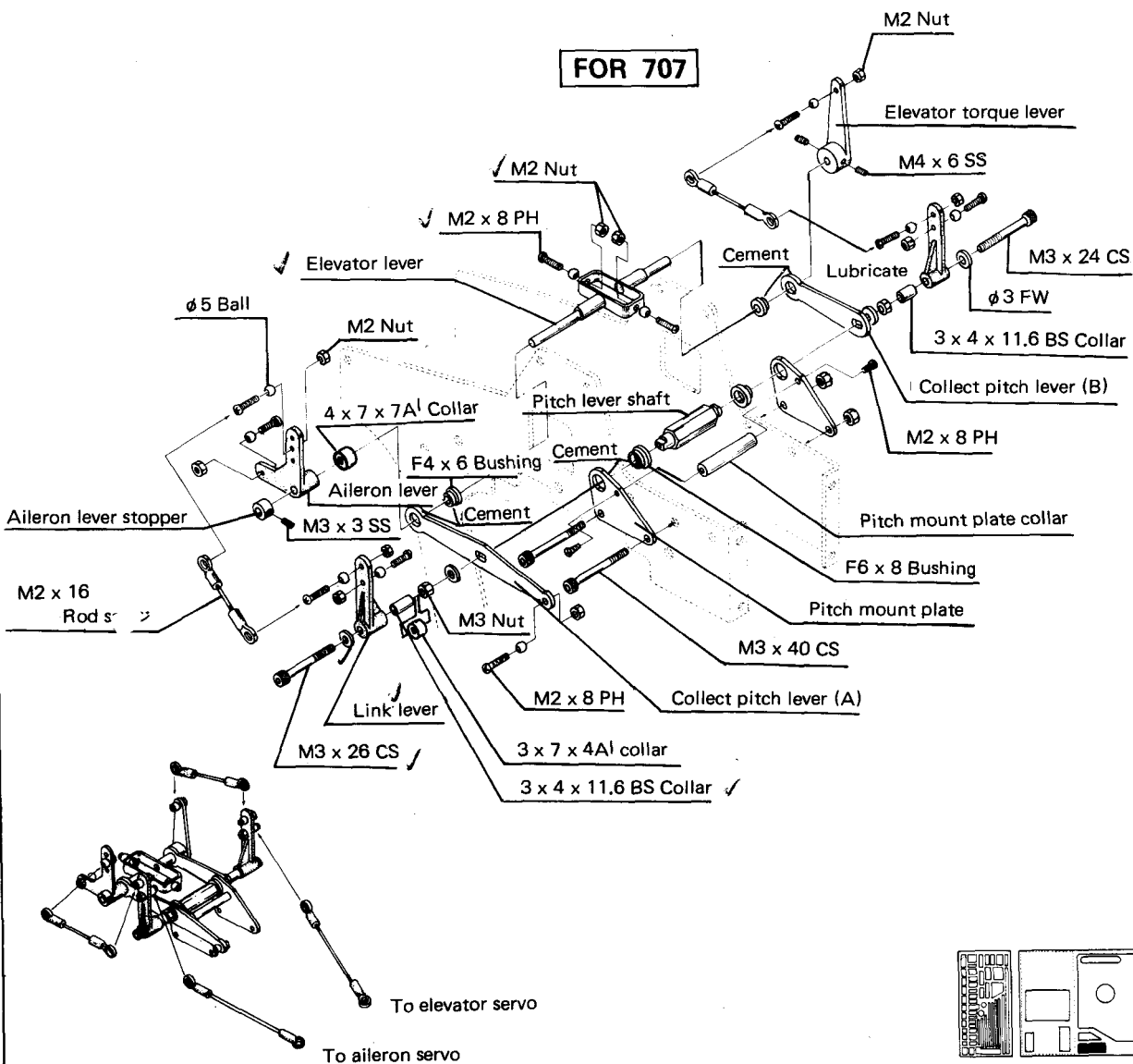

(9). Mounting FRAME (I)

(The illustration below shows 707).

[ The frame for 505 is pre-assembled ]

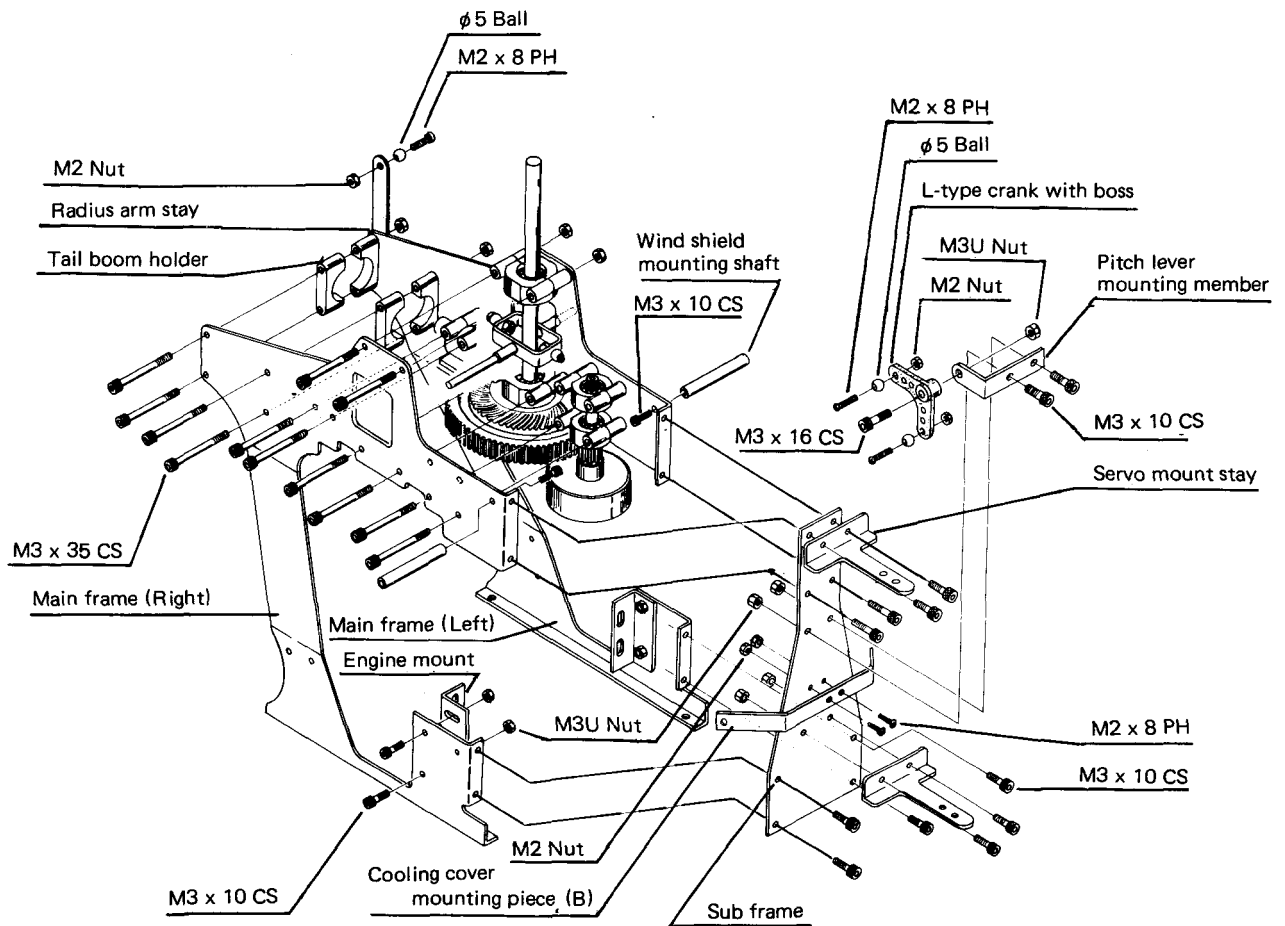

NB:  
Tighten the whole section more  
after the engagement of the bevelled  
spur gears is sufficiently checked.

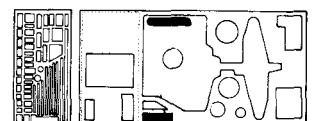



(10). Assembling FRAME (II)

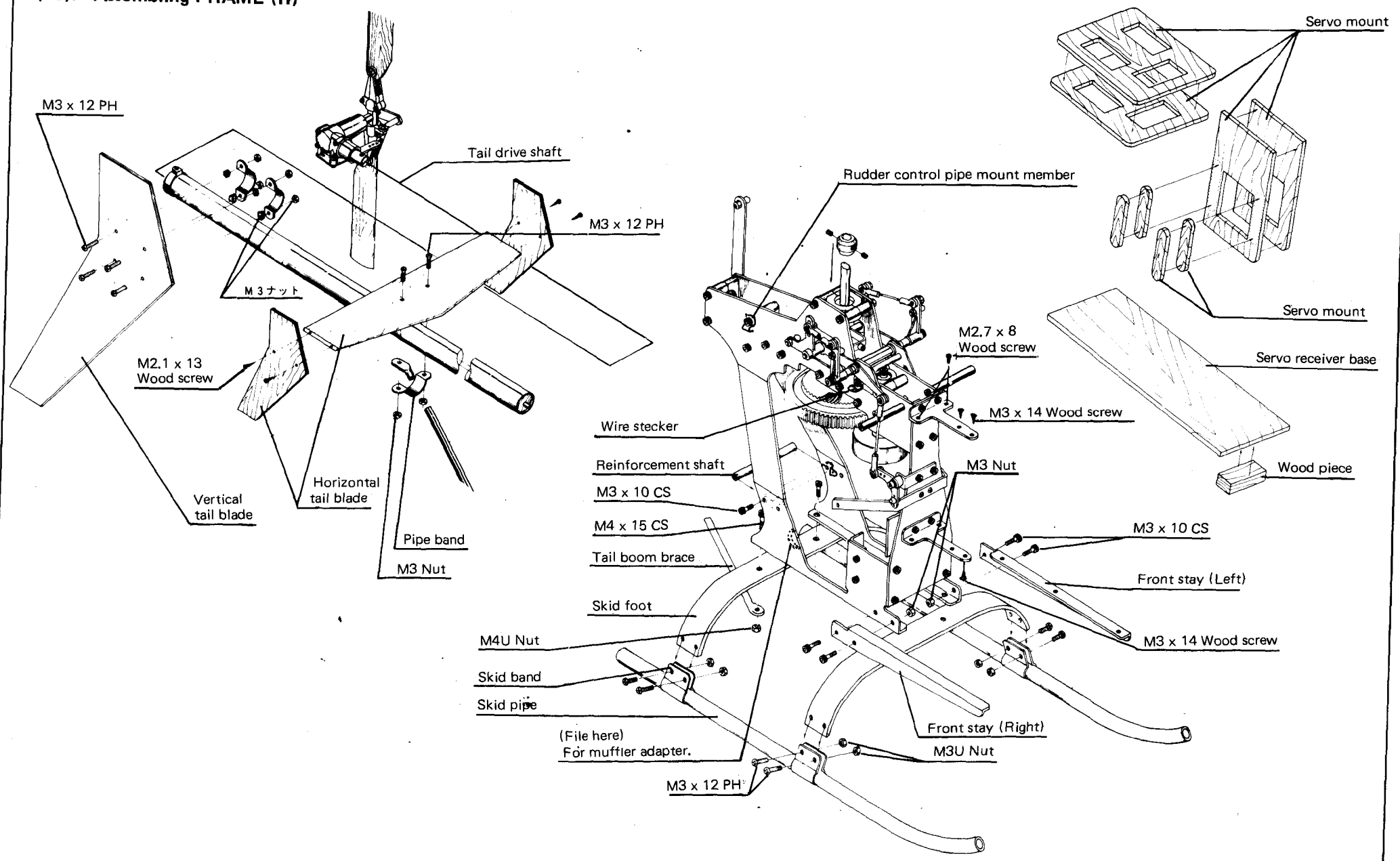

- 8 (K) -

**(11). Mounting ENGINE**

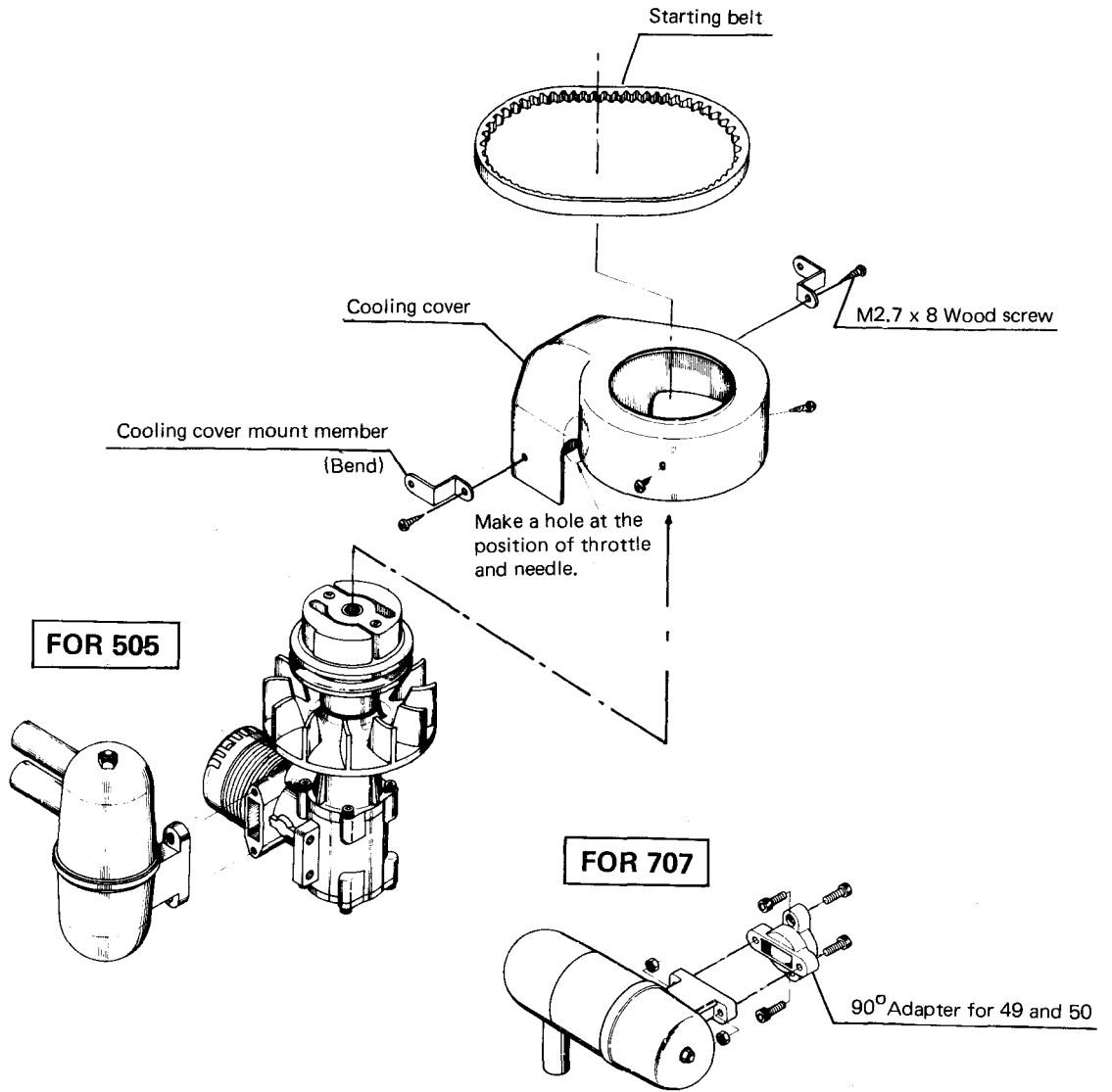

**(12). Balance adjustment of BLADE**

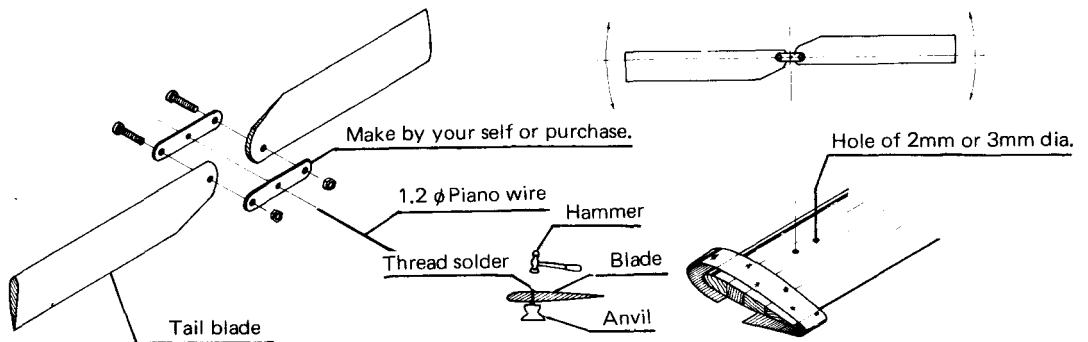

### Arrangement View of servoes for FALCON 505 & 707

A: in case of 4 servoes:

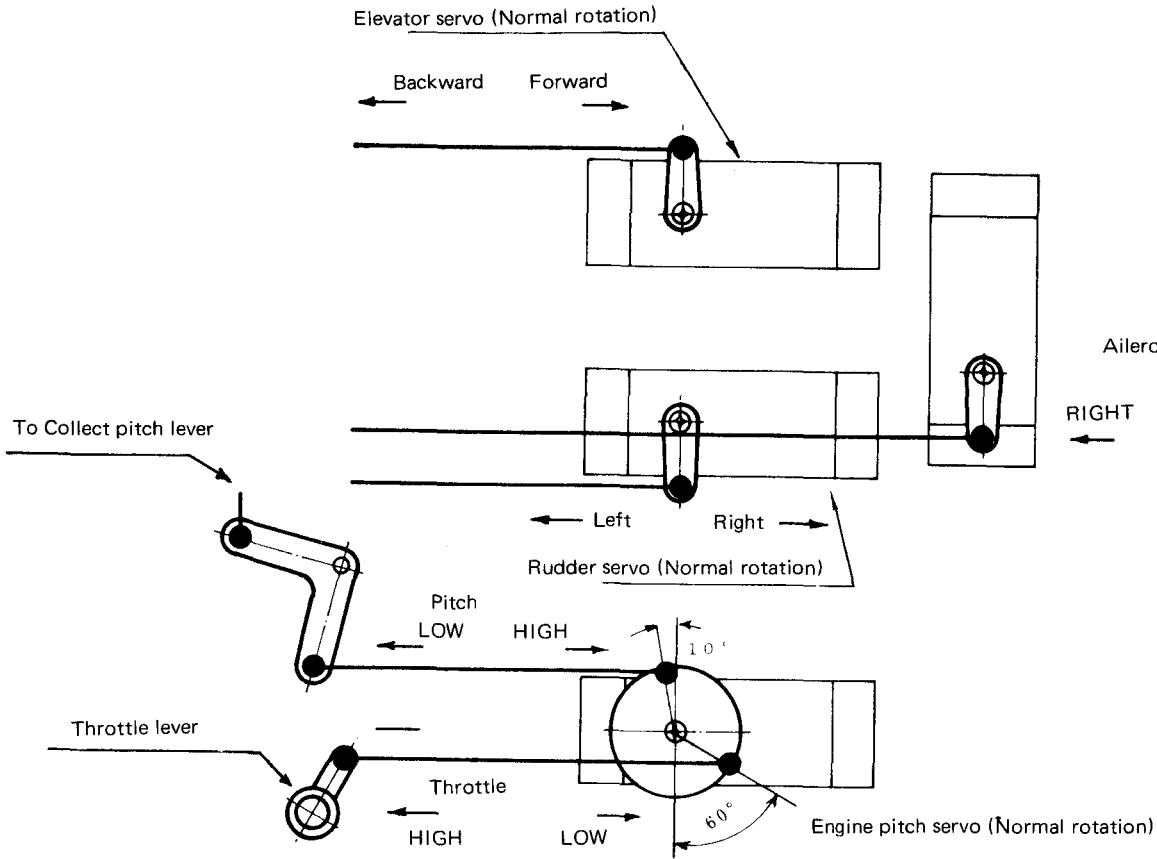

B: In case of 5 servoes:

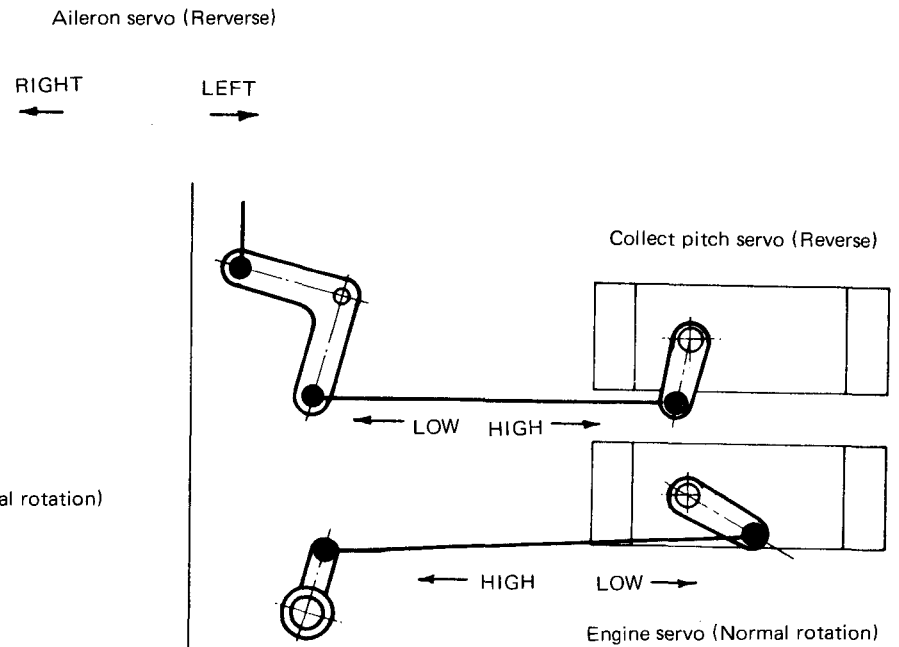

# Servo Linkage for FALCON 505 & 707

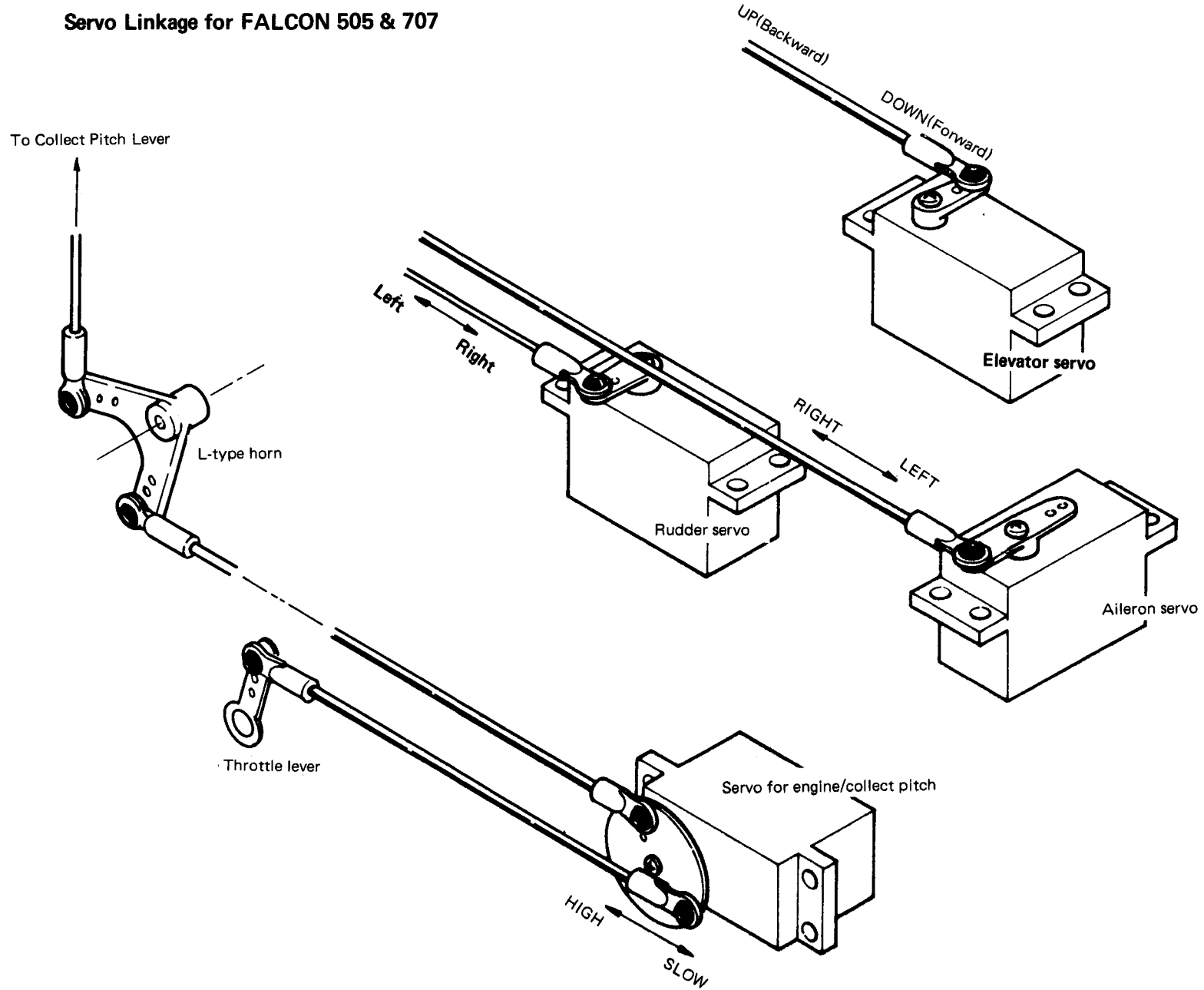

## ADJUSTMENT OF MAIN BLADE PITCH MIXING

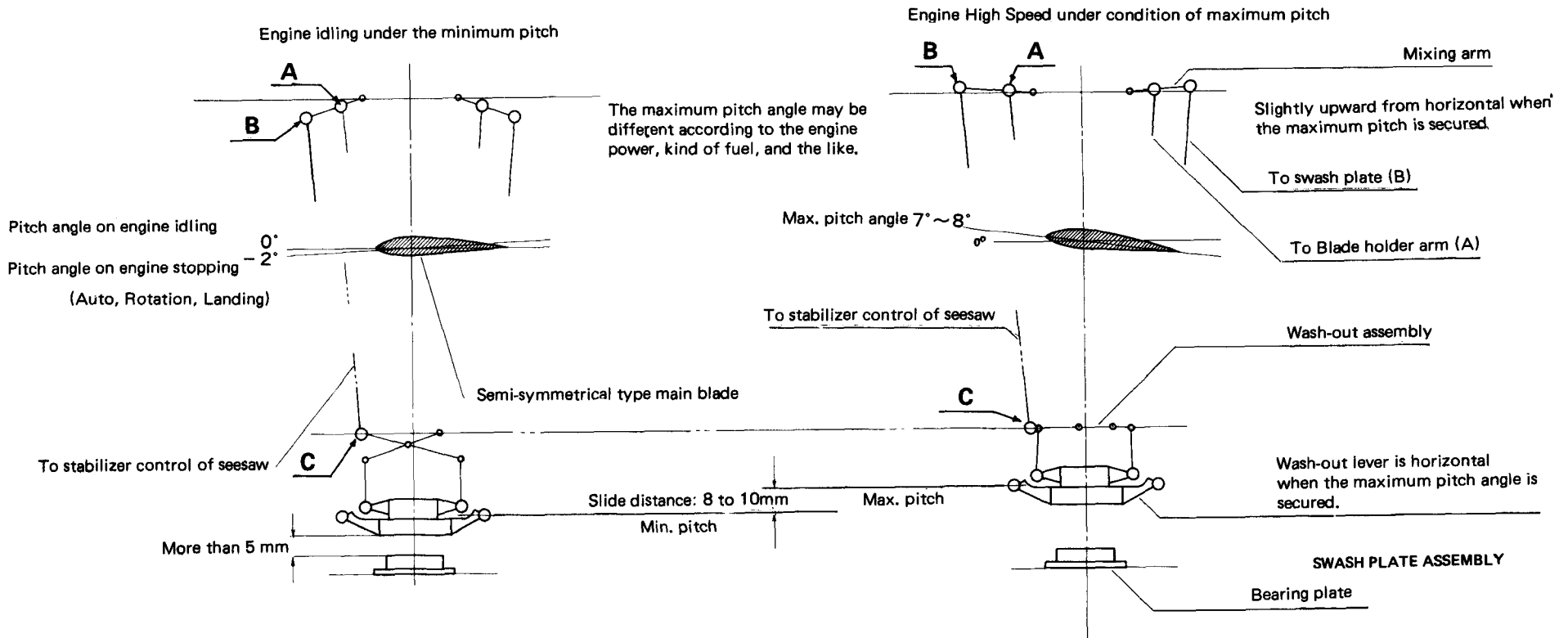

## ADJUSTMENT SECTION

### A. Mounting the servoes & Adjustment of the linkage

Mounting the servoes:

a. Prepare the servoes as follows:

(1). In case 4 servoes are used:

Normal-turn servo ----- 3 pcs.

Reverse-turn servo ----- 1 pc.

(2). In case 5 servoes are used:

Normal-turn servo ----- 4 pcs.

Reverse-turn servo ----- 1 pc.

b. Paying attention to the rotation direction and the mounting position of the rod, mount the servoes in accordance with the arrangement view of the servoes and the drawing.

c. Neutral position of servo horn

Switch on the transmitter and the receiver and set the trim to the central position.

(For engine and pitch control, keep the stick and the trim of the transmitter to the lowest position.)

### Mounting the push-pull rod

In accordance with the servo arrangement view, furnish each servo horn with  $\phi 5$  ball by M2 screw and nut.

a. Aileron

Screw in the rod end to the M2 x 120 adjust rod for aileron and mount the adjust rod at the balls for aileron servo and of pitch-up, link lever. At this time, adjust the length of the rod so that the link lever may become perpendicular with the servo set to neutral.

b. Elevator

Screw in the rod end to the M2 x 80 adjust rod for elevator and mount the rod as well as the aileron. Then, adjust it in the same manners as for aileron.

c. Engine throttle rod

(1). Loosen the SLOW adjust screw about two turns for the engine carburetter and adjust it so that the engine may can completely stop. (Please refer to the instruction manual of the engine which you purchased. )

(2). Mounting the rod at the servo horn : (please refer to the arrangement view of the servoes).

(Use a servo horn whose shape is of disc type).

(i). Mounting angle

On idling ----- About  $60^{\circ}$  position from the lateral center line

(ii). Mounting radius

Full OPEN/Full CLOSE stroke of the carburetter = Rod mounting stroke.

- (3). Transmitter stick, Lowest, Trim, Lowest ----- Engine stops
- Transmitter stick, Lowest, Trim, Intermediate --- Idling
- Transmitter stick, Highest, Trim, Intermediate --- Throttle, Full OPEN

d. Collect Pitch

Mounting the rod at the servo horn:

(i). Mounting angle

On Idling ----- About 10° from the lateral center line.

(ii). Mounting radius

The position where the slide distance of the collect pitch of the adjustment view of the rotor head mixing can be secured. ( Vertical slide distance of the swash plate)

e. Rudder control

(1). Neutral position of the rudder servo

Intermediate position of the engine control stick (in case of prop with mixing for helicopter)

(2). Neutral position of the tail pitch lever

Set the neutral position of the tail pitch lever a little gear box side from the intermediate point of the whole movable range.

(3). Working the control wire:

Solder an adjust joint at one end of the control wire and furnish it with a rod end.

Then, pass it through the control pipe. After that, determine the length and cut off.

Solder the adjust joint. Then, provide it with another rod end.

The part exposed from the control pipe is to be reinforced by soldering.

### ADJUSTMENT OF SERVO LINKAGE

Begin adjusting the linkage of each servo after the rods are mounted at each servo.

- a. Switch on both transmitter and receiver. Set the trim lever of the transmitter to its mean point. Check the rotation direction of each servo. Then, check that the horn of each servo is set at the neutral position.

NB: For the aileron/elevator, check that the link lever of the pitch up mechanism is vertical.

- b. The relationship between the swash plate and control rod is as follows:

Aileron:	Lever (L) point	Swash plate (L) Point	Rod (L) point
Elevator:	Lever (F-1) Point	Swash plate (F-1) Point	Rod (F-1) Point
Elevator:	Lever (F-2) Point	Swash plate (F-2) Point	Rod (F-2) Point

Mount the swash plate and the control rod in a position by screwing in the rod ends to M2 both-side threaded screw rods of the designated dimension of each helicopter.

At this time, adjust the swash plate so that it may be horizontal ( have a right angle to the mast in both forward/backward and left/right directions ) and that the clearance between the upper surface of the bearing plate and the lower surface of the swash

plate may be 5mm to 6mm . For this purpose, control the length of the rods by the screw-in distance of the rod ends.

**B. Linkage of the rotor head**

Rod (A)	Plate holder (A)	Mixing arm (A)
Rod (B)	Swash plate (B)	Mixing arm (B)
Rod (C)	Wash-out (C)	Seesaw (C)

- a. Mount the rod (A) by uniformly screwing in the rod ends at both ends of the M2 x 16 screw..
- b. Rod (B)  
Switch on the transmitter and lift up the engine control lever to the highest position to shift the swash plate for maximum pitch. Then, furnish the M2 rod of the designated dimension of each helicopter with a rod end. Adjust the length of the rod so that the mixing arm may become a little upward with the seesaw kept horizontal.
- c. Rod (C)  
Fix the wash-out to the mast so that the control arm of the wash-out may become horizontal under the conditions described in (b).

**NB:**

Fix the wash-out at the position wherefour horns of the lower side of the swash plate may be piled up on the four horns of the upper plate with the rotor blade placed on the center line of the body (i.e. body length direction).

For the rod, furnish the adjust rod of the designated dimension of each helicopter with rod ends by screwing in, lead it to the wash-out (C) point through the seesaw (C) point and the inside of the yoke.

At this time, bend the rod near the wash-out so that it may not come in contact with the yoke. And adjust the length of the rod so that the stabilizer blade may become horizontal.

**BALANCE ADJUSTMENT OF ROTOR BLADE**

**a. Main rotor blade**

The main rotor blade rotates at high speed. So, if complete balance is not secured, poor ruddering and/or vibrations may be caused to be present. Therefore, obtain complete balance of the main rotor blade.

First of all, place a round pencil or a mast on an even table or so. Then, put the two blades on it. Under these conditions, roll the pencil or the mast to look into the center of gravity of the blade in the length direction. Then, mark the center of gravity with a pencil or so.

Check that the center of gravity of the two blades is located at the same position.

If error more than 5mm is caused, make an opening of 2mm dia. at the tip or the root of the lighter blade and caulk a thread type solder in the opening to true up the centers of gravity of the two blades.



Next, adjust the balance of the weight of the two blades. At this time, use a blade balancer to secure complete balance of the blades.

b. Tail rotor blade

As the tail rotor blades rotate at the speed of 4,000 to 6,000 rpm., secure complete balance of the tail rotor blades by the same method as that for the main rotor blades.

c. Protection of the blades

As the weight balance of the blades may change to the humidity content in the air, stick the adhesive tape (film) to the blade surfaces to protect it from humidity.

Do the same in the tail blades.

d. Coloring of blade ends of the main rotor:

It is impossible to adjust the tracking of the main rotors if it is not possible to distinguish the tracks of the blade ends of both right and left blades. So, provide the blade ends with a distinguishable color tape.

e. Adjusting the pitch angle of the main blade:

Switch on both transmitter and receiver. Set the engine control trim to the intermediate position (Idling) and set the stick to the lowest position.

Next, Hold the stabilizer bar with your hands to make the seesaw horizontal. Check that , when observed from the rotor blade end, the line connecting the front end of the blade section surface with the rear end is parallel to the stabilizer bar. If not, adjust the rod (A) ( the inside point (A) of the mixing arm – the blade holder (A) point) so that the line may become parallel to the stabilizer bar. At this time, the blade pitch angle is zero (0).

f. Adjusting the maximum pitch angle

Since the maximum pitch angle may change to the engine output and the fuel , it is adequate that the maximum pitch angle is set to 7 to 8<sup>o</sup> degrees of angle in usual cases. Measure it by a pitch gauge. The standard judgement is as follows; For 60 mixing arm, if the distance along which the swash plate lets the mast slide when moving the engine control stick from the lowest to the highest is 10mm, the maximum pitch angle may be roughly 8<sup>o</sup>. For 50 mixing arm, if the distance is 7mm, the maximum pitch angle is 8<sup>o</sup>.

g. Adjusting the tail rotor pitch angle

The following description covers the adjustment of the tail pitch when the mixing prop for helicopter is used. ( Please refer to the instruction manual of the transmitter). Set the knob for tail mixing adjustment , of the transmitter, to the intermediate position and set the engine control stick a little upward from the mean point. (Hovering position). At this time, check that the horn of the rudder servo is located at the neutral position.

Loosen the screws of the tail pitch plate stoppers and shift the pitch plate so that the pitch angle of the tail blade may become zero ( $0^{\circ}$  degree) with the engine control stick lowered to the lowest position.

Adjust the length of the rudder servo horn so that the tail rotor may move by  $35$  to  $40^{\circ}$  in either direction when controlling the rudder control stick in each direction with the engine control stick set to the hovering position.

C CHECKS AND INSPECTION BEFORE FLYING

For the center of gravity

The center of the gravity is to be so located that the skid pipe may be a little inclined forward from the horizontalness when holding the stabilizer bar by your hands.

Never locate the center of gravity so that the skid pipe may be inclined backwards.

Checking each point before flight

Adjusting the blades and tracking

Supply fuel in the tank. Check that the engine control lever of the transmitter is set to SLOW position and the trim lever of the transmitter may be set to IDLE position.

After that, start the engine.

After the engine starts, firmly hold the rotor head and step on the skid. Then, race the engine with loud roar two or three times. At this time, if the head tries to rotate strongly, the clutch is completely engaged. If you feel it a little weak, immediately slow down the engine. Try to touch the clutch bell (be careful for overheating). If the bell is heated, cool it by waste cloth or water. Never engage the clutch with high temperature left. (because the clutch shoe is made of resin).

When the clutch bell is cooled to be normal, again try to do setting it for complete meeting.

After the meeting(engagement) of the clutch shoe is checked, gradually increase the rotation speed of the engine. At this time, if the tip ends of the main rotor can be doubly seen when the helicopter is going to land off, distinguish the color of the two rotors to see which blades is higher than the other. In this case, screw in the rod end of the rotor rod (A) of a rotor which goes undersides. Through these procedures, adjust the two main rotors until they can be seen single.

After the tracking adjustment is completed, slow down the engine for idling and check

the pitch angle is zero (0° degree). If not so, adjust by screwing in the rod ends of both rods (A) by the same turns.

#### D. ADJUSTMENT OF FLIGHT

After that tracking adjustment is completed, begin to adjust the trims.

First of all, for the beginners, bend both ends of aluminum pipe or bamboo and mount them to the landing skid by vinyl tape or the like to prevent the helicopter from barrel roll.

##### Adjustment of each trim

Gradually increase the rotation speed of the engine to float the helicopter body by 10 to 20 cm from the ground level. If the helicopter moves forwards or backwards, use an elevator trim for correction. Or if the helicopter is inclined in the right and left direction, use the aileron trim for correction. For the rudder, use the rudder trim for correction, too. Adjust the length of each rod so that the helicopter may be floated with the trim lever set to NEUTRAL.

In case of the rudder, loosen the screw of the tail pitch plate stopper and take the pitch plate outside if the trim lever is located right. To the contrary, if the trim lever is located left, take the pitch plate inside for rudder adjustment. For further details, please refer to the instruction manual of the mixing prop which you use.

##### FLIGHT ( In case of beginner )

Fill the tank with fuel after the whole adjustment is completed, in order to be ready for landing off. But wait a moment. breathe deeply and set your mind at ease. Pay a great attention to the neighbors, childrens or the surroundings. After the safety of the surroundings is confirmed, start the engine and turn the head of helicopter windwards.

If you stand back of the helicopter, you can not observe the posture of helicopter in the elevator direction, causing the control to become impossible. Therefore, please stand at the side of the helicopter.

Confirm the safety of the surroundings again. Gradually increase the rotation speed of the engine. Here, if the helicopter moves backwards, set the elevator trim to a little forward side so that the helicopter lands off as moving forwards.

Gradually increasing the rotation speed of the engine, the body begins to be floated from the rear part of the landing skid. At this time, increase the engine control stick by two or three units, and the helicopter advances as being floated.

At first, please don't float the helicopter more than 30cm high. If it is too high, lower the engine control stick to land the helicopter. Then, float it again and walk together with the helicopter. After you reach the end of the yard as repeating the floating and landing of the helicopter, bring it back to the start point. If the control is effected only in one side of the engine, a vice may be caused to be present. Exercise at both sides of the helicopter. Lateral inclination is corrected by aileron, forward/backward inclination by

elevator, and the direction control by rudder. If you master these controls, you may perform hovering and fly it high in the air.

## **E SAFETY MEASURES FOR R/C HELICOPTERS**

Now, you have assembled your KIT with your heart and skill, To ensure comfortable and safe flight of the helicopter, please keep the followings.

**(1). Selection of flying yard**

Select as wide and vacant flying yard as possible. And select a flying yard that is free from any transformer substation, high-voltage electric wires, and/or buildings.

**(2). Cautions before flying**

Check if the R/C unit is actuating without fail before engine starts. Check all the screws, nuts and /or linkages to see if they are loosened or not.

**(3). Cautions for flight**

When you begin to operate your helicopter, pay attention to the neighbors. Please never let the people approach to the helicopter. Please do not fly your helicopter on or over houses, trains, and cars, power-transmission lines, and warehouses of combustible matters. If you find that the output of the helicopter is lowered, please immediately land it on a safe place. please never let childrens or viewers approach to the helicopter.

**(4). Check the screws and nuts or bolts to see if they are loosened or not.**

Please pay attention specially to the rotary parts of the rotor head. If you should find a loosening or a rattling, immediately give complete adjustment before flying.

**PARTS ARRANGEMENT & NAME OF PARTS FOR FALCON 707**

The table below shows the parts of the drawings and of the illustrations and the arrangement number of the parts in the parts case.

Arrangement no. of parts	Parts Number	Parts Particulars	Quantity required
DK-(1)	DK1-1	Swash upper plate	1
DK-(2)	DK2-1	Swash joint ring (A)	1

**Remarks:**

The quantity and quality of the kits have been well checked and inspected before shipment. However, if you should find anything inconvenient, please immediately inform us (the head office) or the shop, where you purchased, together with the parts number eg. DK-0-0.

The specifications shall be subject to change without prior notice.

Arrangement no. of parts	Parts Number	Parts Particulars	Quantity required
DK-(1)	DK1-1	Swash upper plate	1
	DK1-2	Swash joint ring (A)	1
	DK1-3	Swash joint ring (B)	1
	DK1-4	Swash lower plate	1
	DK1-5	Bearing 20-25	1
	DK1-6	SF-8	1
	DK1-7	M2 x 6 Pan head machine screw	4
	DK1-8	Swash lower lock	1
	DK1-9	Swash plate boot	1
DK-(2)	DK2-1	Expert stabilizer blade	2
DK-(3)	DK3-1	New blade holder	2
	DK3-2	New yoke	1
	DK3-3	Bearing 10-15	2
	DK3-4	Bearing 15-20	2
	DK3-5	Thrust CRT 6-12	2
	DK3-6	φ4 Hardened washer	2
	DK3-7	Thrust collar	2
	DK3-8	M4 x 25 Cap screw	2
	DK3-9	φ4 Flat washer	2
	DK3-10	Gimbal seesaw	1
	DK3-11	New center hub	1
	DK3-12	Main blade root end	2
DK-(4)	DK4-1	Cooling fan	1
	DK4-2	Cooling fan imbedding member	1

Arrangement no. of parts	Parts Number	Parts Particulars	Quantity required
DK-(5)	DK4-3	Starter pulley	1
	DK5-1	Clutch shoe	1
	DK5-2	Bearing HK0609	1
DK-(6)	DK6-1	Tail holder	1
DK-(7)	DK7-1	Tail pitch lever	1
	DK7-2	Tail gear box (A)	1
	DK7-3	Tail gear box (B)	1
	DK7-4	Miter gear, Right	1
	DK7-5	Miter gear, Left	1
	DK7-6	Tail, 1st shaft	1
	DK7-7	Tail, 2nd shaft	1
	DK7-8	Tail housing	1
	DK7-9	Thrust coupling	2
	DK7-10	7 x 11.1 BS Collar	1
	DK7-11	3 x 5 BS Collar	1
	DK7-12	7 x 7BS Collar	1
	DK7-13	Tail pitch rod	1
	DK7-14	M2 x 10 Pan head machine screw	5
	DK7-15	φ2 Flat washer	2
	DK7-16	Bearing 685 OP	2
DK7-17	Bearing 685 ZZ	2	
DK7-18	3.2 x 8 Thrust bearing	2	
DK7-19	M3 Nut	4	
DK7-20	M4 x 4 Set screw	2	
DK7-21	Joint (A)	1	
DK-(8)	DK8-1	Main frame (Right)	1
	DK8-2	Main frame (Left)	1
	DK8-3	50 Engine mount	2
	DK8-4	Enya Engine collar	1
	DK8-5	Main mast	1
	DK8-6	Bevelled spur gear	1
	DK8-7	Auto rotation assembly	1
	DK8-8	Radius arm	2
	DK8-9	Mast block	1
	DK8-10	Control arm	1
	DK8-11	Pivot arm	1
	DK8-12	Pivot arm collar	2
	DK8-13	φ8 Wash-out collar	1
	DK8-14	Bearing 608	2
	DK8-15	608 Bearing holder	4
	DK8-16	606 Bearing holder	4
DK-(9)	DK9-1	Sub frame	1
	DK9-2	Front stay (Right)	1
	DK9-3	Front stay (Left)	1
	DK9-4	Servo mount stay	2
	DK9-5	Starting belt	1
	DK9-6	Main frame reinforcement shaft	1
	DK9-7	Pitch lever mounting member	1
	DK9-8	Cooling cover mounting member(B)	1
DK-(10)	DK10-1	4 x 7 x 7 Al collar	1
	DK10-2	3 x 7 x 4 Al collar	1
	DK10-3	3 x 4 x 11.6 BS Collar	2
	DK10-4	F4 x 6 x 2.5 : 8 x ;	2
	DK10-5	F6 x 8 x 3 : 10 x 1	2
	DK10-6	Aileron lever stopper	1
	DK10-7	Tail boom holder	4

**DK-1**

Arrange-ment no. of parts	Parts Number	Parts Particulars	Quantity required	Arrange-ment no. of parts	Parts Number	Parts Particulars	Quantity required	
DK-(11)	DK11-1	Collect pitch lever (A)	1	DK-(22)	DK22-1	Adjust joint (B)	2	
	DK11-2	Collect pitch lever (B)	1	DK-(23)	DK23-1	Pipe band	3	
	DK11-3	Aileron lever	1	DK-(24)	DK24-1	(New) Windshield mounting shaft	2	
	DK11-4	Link lever	2	DK-(25)	DK25-1	Wire stecker	1	
	DK11-5	Elevator lever	1	DK25-2	DK25-2	Cooling cover set member (A)	2	
	DK11-6	Elevator torque lever	1	DK25-3	DK25-3	Rudder pipe set member	1	
	DK11-7	Pitch lever shaft	1	DK-(26)	DK26-1	50 Carb.lever collar for OS	1	
	DK11-8	Pitch lever mount plate	2		DK26-2	49 carb. lever collar for ENYA	1	
	DK11-9	Pitch mount plate collar	1		DK26-3	M3 x 25 JIS Cap screw	1	
	DK11-10	L-type crank with boss	1	DK-(27)	DK27-1	Taper spacer	1	
DK-(12)	DK12-1	Bevelled pinion gear	1	DK-(28)	DK28-1	Mast lock	1	
	DK12-2	Bevel pinion shaft	1	DK-(29)	DK29-1	M2 x 120 Adjust rod	1	
	DK12-3	Bearing 605 OP	2	DK-(30)	DK30-1	M2 x 110 Adjust rod	1	
	DK12-4	605 Bearing holder	2	DK-(31)	DK31-1	M2 x 100 Adjust rod	1	
	DK12-5	7 x 8 NS Collar	1	DK-(32)	DK32-1	M2 x 80 Adjust rod	1	
	DK12-6	Joint (A)	1	DK-(33)	DK33-1	M2 x 55 Adjust rod	3	
	DK12-7	M4 x 4 Set screw	2	DK-(34)	DK34-1	M2 x 50 Adjust rod	1	
DK-(13)	DK13-1	Mixing arm (for 50)	2	DK-(35)	DK35-1	M2 x 35 Adjust rod	1	
	DK13-2	Mixing arm holder	2	DK-(36)	DK36-1	M2 x 16 Rod screw	2	
	DK13-3	Seesaw Bearing Holder	2	DK-(37)	DK37-1	L-type wrench 1.5mm	1	
	DK13-4	Gimbal shaft	1	DK-(38)	DK38-1	M3 x 10 Cap screw	24	
	DK13-5	LF 940	2	DK-(39)	DK39-1	M3 x 12 Cap screw	6	
	DK13-6	Yoke damper collar A	1	DK-(40)	DK40-1	M3 x 16 Cap screw	3	
	DK13-7	Yoke damper collar B	1	DK-(41)	DK41-1	M3 x 20 Cap screw	4	
	DK13-8	Yoke dust cap	2	DK-(42)	DK42-1	M3 x 25 Cap screw	2	
	DK13-9	M2 x 16 Rod screw	2	DK-(43)	DK43-1	M3 x 26 Cap screw	1	
	DK13-10	HK 0408	2	DK-(44)	DK44-1	M4 x 15 Cap screw	4	
	DK13-11	Gimbal shaft bushing	2	DK-(45)	DK45-1	M3 x 10 Pan head machine screw	3	
	DK13-12	Adjust rod M2 x 100	2	DK-(46)	DK46-1	M3 x 35 Cap screw	12	
	DK13-13	Adjust rod M2 x 70	1	DK-(47)	DK47-1	M3 x 3 Set screw	5	
DK-(14)	DK14-1	Spur gear with shaft	1	DK-(48)	DK48-1	M3 x 5 Set screw	2	
	DK14-2	Clutch bell	1	DK-(49)	DK49-1	M4 x 4 Set screw	3	
	DK14-3	φ2 x 14 Roll pin	1	DK-(50)	DK50-1	M4 x 6 Set screw	15	
	DK14-4	M3 x 10 Cap screw	1	DK-(51)	DK51-1	M3 x 12 Pan head machine screw	14	
	DK14-5	Bearing 606 OP	2	DK-(52)	DK52-1	M2 x 10 Pan head machine screw	13	
	DK14-6	Spacer for 1st shaft	1	DK-(53)	DK53-1	φ 2 x 11.8 Needle pin	4	
	DK14-7	φ3 Flat washer	1	DK53-2	DK53-2	φ 3 x 16 Needle pin	1	
CONTENTS IN MECHANICAL CASE B				DK53-3	DK53-3	φ 4 x 29.8 Needle pin	1	
DK-(15)	DK15-1	Tail pitch plate	1	DK-(54)	DK54-1	φ 2 Flat washer	4	
	DK15-2	3 x 5 BS Collar	1		DK54-2	DK54-2	φ 2.5 Flat washer	5
DK-(16)	DK16-1	Stabilizer bar	2		DK54-3	DK54-3	φ 3 Flat washer	24
DK-(17)	DK17-1	Rod end	34		DK54-4	DK54-4	φ 4 Flat washer	2
DK-(18)	DK18-1	φ5 Ball	30	DK-(55)	DK55-1	M3U Nut	52	
DK-(19)	DK19-1	Rod adjuster	2	DK-(56)	DK56-1	M4U Nut	8	
	DK19-2	Pivot bolt A	2	DK-(57)	DK57-1	M3 Nut	15	
DK-(20)	DK20-1	M3 x 40 Cap screw	2					
	DK20-2	M4 x 30 Cap screw	2					
DK-(21)	DK21-1	Tail blade holder (A)	2					
	DK21-2	Tail blade holder(B)	2					
	DK21-3	Tail pitch plate stopper	2					

Arrangement no of parts	Parts Number	Parts particulars	Quantity required	Arrangement no. of parts	Parts Number	Parts Particulars	Quantity required
DK-(58)	DK58-1	M2 Nut	31		DK80-3	Rudder control wire	1
DK-(59)	DK59-1	M3 x 14 Wood screw	6		DK80-4	Rudder control pipe	1
DK-(60)	DK60-1	M2.1 x 13 Wood screw	4				
DK-(61)	DK61-1	M2.7 x 8 Wood screw	10				
DK-(62)	DK62-1	M2 x 14 Pan head machine screw	4				
DK-(63)	DK63-1	M2 x 8 Panhead machine screw	27				
DK-(64)	DK64-1	M2 x 6 Pan head machine screw	6				
DK-(65)	DK65-1	M2.6 x Tapping screw	5				
DK-(66)	DK66-1	New damper rubber	1				
	DK66-2	M3U Nut	2				
	DK66-3	M2 Nut	2				
	DK66-4	M3 x 10 Cap screw	1				
	DK66-5	M2 x 8 Pan head machine screw	1				
	DK66-6	M2 x 10 Pan head machine screw	1				
	DK66-7	M2 x 15 Pan head machine screw	1				
The following parts are arranged and provided in the lower section of the mechanical case.							
DK-(67)	DK67-1	Cabin	1				
DK-(68)	DK68-1	Windshield	1				
	DK68-2	Mechanical cover	1				
DK-(69)	DK69-1	Servo mount (A)	2				
	DK69-2	Servo mount (B)	2				
	DK69-3	Servo mount base	4				
	DK69-4	Receiver base	1				
	DK69-5	Horizontal tail blade	1				
	DK69-6	Vertical tail blade	1 set				
	DK69-7	Tail drive shaft base	3				
DK-(70)	DK70-1	Control panel 20 x 40 x 12	2				
DK-(71)	DK71-1	Instruction manual	1				
DK-(72)	DK72-1	Parts list	1				
DK-(73)	DK73-1	Drawing	1				
DK-(74)	DK74-1	Tail pipe	1				
	DK74-2	Tail boom brace	2				
DK-(75)	DK75-1	50 Cooling cover	1				
DK-(76)	DK76-1	Transcribing mark	1				
DK-(77)	DK77-1	Fuel tank	1				
DK-(78)	DK78-1	Semi-symmetrical main blade	2				
	DK78-2	Semi-symmetrical tail blade	2				
DK-(79)	DK79-1	Skid foot	2				
	DK79-2	Skid pipe	2				
	DK79-3	Skid band	4				
DK-(80)	DK80-1	Tail drive shaft	1				
	DK80-2	Tail drive shaft	1				
			1				

**PARTS ARRANGEMENT VIEW OF MECHANICAL CASES**

**FALCON 505  
FALCON 707**

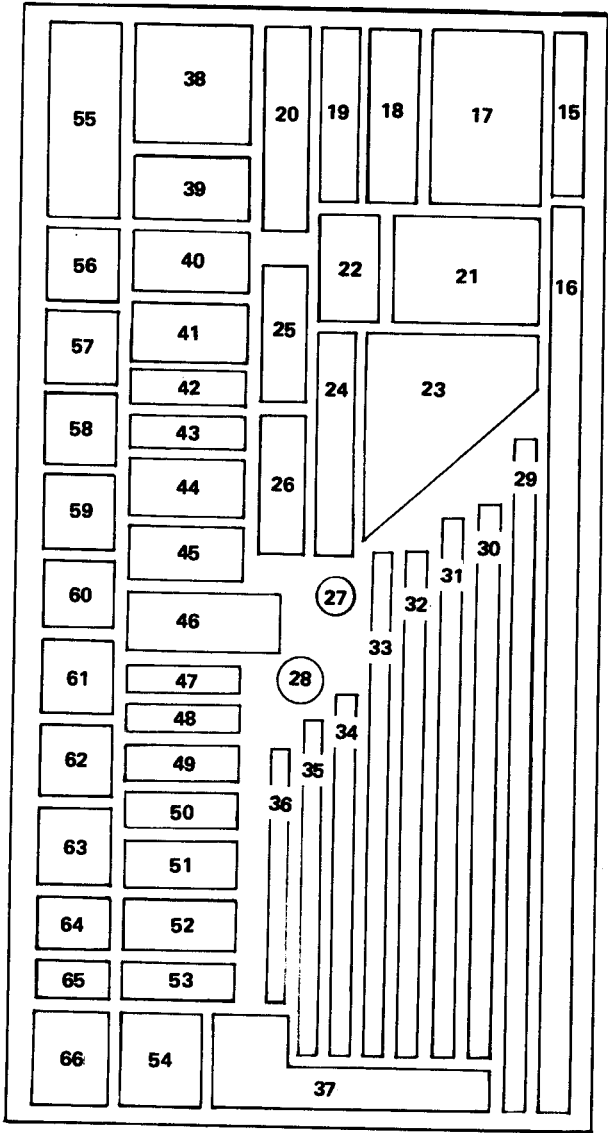

**Mechanical case B**

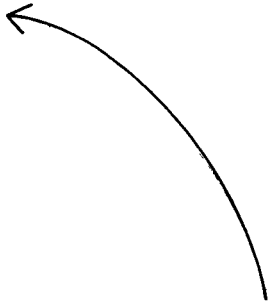

**Mechanical case A**

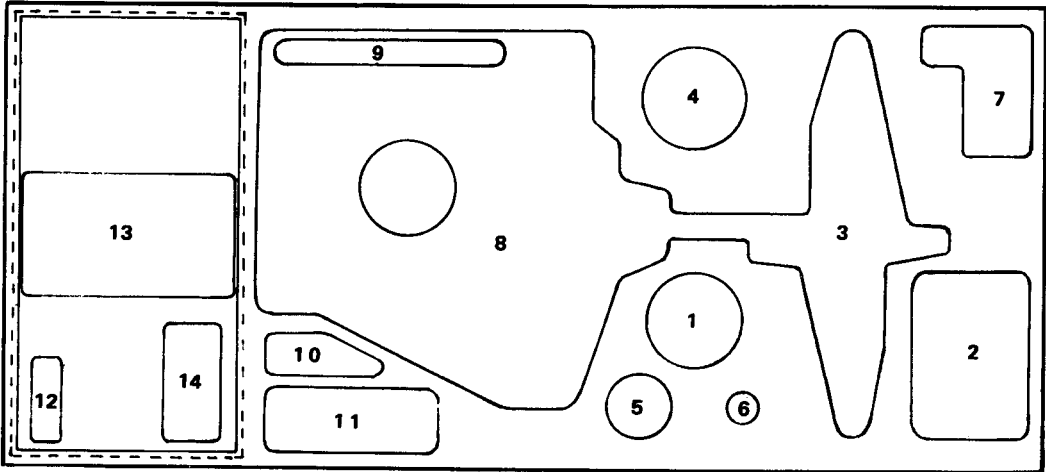

※ (12), (13) and (14) are arranged and provided only in FALCON 707.



ヒロボ-R/C フアルコン “707”をお買上げいただき誠にありがとうございました。キットの内容及び数量については、十分な検査を致しておりますが、念のため各部品小袋内の数量確認を行なって下さい。

万一不足のあった場合はお手数ですがそのままお買上店又は弊社まで御連絡下さい。

Thank you very much for your purchase of Hirobo R/C model helicopter Falcon 707. Through the quality and quantity of the model kits have been severely checked before shipment, please re-check the quantity of the components and parts contained in each small sack in order to make doubly sure. If you should find anything wrong, please be free to contact the shop where you have purchased or directly Hirobo Industrial Co., Ltd.

---

検査 Inspection



**ヒロボ株式会社**

広島県府中市府川町234 〒726 ☎(0847)45-3470

HIROBO INDUSTRIAL CO., LTD.

234, Fukawa-cho, Fuchu-shi, 726, Hiroshima, Japan.

Cable:Hirobo Fuchuhiroshima Telex:6457-77 Hirobo

---