



RAPTOR

E550 | E620 SE



MANUAL

ASSEMBLY & MAINTENANCE

INTRODUCTION

Congratulations on your purchase of the Thunder Tiger Raptor E Series helicopter. Basically, the design of the Raptor E Series is based on the original well-known Thunder Tiger Raptor 30/50 V2 nitro engine helicopters. The new Raptor E Series are equipped with the same R30/50 V2 rotor head and tail drive system, and they adopt the E-CCPM control system of 90° and 140°. They combine the elements of the previous successful design with the popular E-CCPM system at present time. All push-pull linkage makes the response of the control much more quickly and precisely. Using of aluminum/carbon lower battery tray to get the best power-to-weight ratio so that the extreme 3D flying is performed without hesitation. If you want to fly without noise and pollution, Raptor E Series are the best choice with no doubt. Beginners and 3D pilots will be impressed with the new Raptor E Series.

CONTENTS

Introduction.....	p.1	Assembling Section.....	p.4
Contents.....	p.1	Introduction of E-CCPM.....	p.22
Warnings.....	p.1	Linkage Set-up.....	p.30
Additional Items Needed.....	p.3	Trouble Shooting.....	p.35
Tools Needed.....	p.3	Parts List Section.....	p.36

WARNING

This radio controlled helicopter is not a toy. It is a sophisticated piece of equipment and is designed for hobby use only. If not properly assembled and operated, it is capable of causing property damage and bodily harm to both the operator and spectators. Thunder Tiger and its duly authorized distributors assume no liability for damage that could occur from the assembly or operation of this product.

AMA INFORMATION

Operating a model helicopter requires a high degree of responsibility and skill. If you are a newcomer to the hobby, it is best to seek help and guidance from accomplished model helicopter pilots. This will greatly speed up the learning process and have you flying successfully in a reasonable amount of time. We also would strongly urge you to join the Academy of Model Aeronautics. The AMA is a non-profit organization that provides its members with a liability insurance plan as well as monthly magazine entitled Model Aviation. All AMA charter aircraft clubs require all pilots to hold a current AMA sporting license prior to operation of their models at club fields. For further information, contact the AMA at:

Academy of Model Aeronautics
5151 East Memorial Drive
Muncie, IN 47302
(317) 287-1256

FLIGHT SAFETY CHECKLIST

1. Make sure both batteries of the transmitter and the receiver are fully charged before flying.
2. Make sure all the control surfaces are operated properly before flying.
3. Do a range check of the radio before the first flight. The electronic equipment must be operated properly with the antenna of the transmitter collapsed at a range of 50 ft (15 meter) at least.
4. Make sure there is no radio interference on your radio frequency before flying.
5. We are strongly recommended to connect an anti-interference ring between the ESC and the receiver.
6. Be sure to turn on the transmitter first and the throttle stick must be in the idle position, and then turn on the receiver and plug the battery in at last.
7. The main rotor and the tail rotor are at very high RPM. Make sure nothing can come in contact with the rotor blades during flight.
8. Always maintain a safe distance from the helicopter during flight.
9. Never fly the helicopter in the rain or in excessive wind conditions.
10. Always operate and fly the helicopter in a safe and responsible manner.
11. Never fly the helicopter over other pilots, spectators, cars or anything that could result in injury or property damage.

POST FLIGHT INSPECTION

1. Inspect the model thoroughly to insure no parts have come loose or become damaged during the flight and landing. Replace damaged parts and tighten loose screws before flying again.
2. Clean the helicopter body.
3. Lubricate all moving parts to ensure smooth operation for the next flying.
4. Replace any loose ball links and damaged bearings.
5. Store the model in a cool, dry place. Avoid putting it under direct sunlight or near a source of heat.

Following these simple rules will allow you to enjoy the thrill of model helicopter flying for many years.

CAUTION: In the event model has crashed, inspect the flybar, rotor shaft and the blade spindle to make sure they are not bent. If any item is damaged, it must be replaced with a new part to ensure safe operation. Do not glue any broken or damaged plastic parts. Do not repair broken rotor blades. It is very important to inspect the motor, speed control and the battery.

Always inspect the following items:

Gears, Ball links, Link rods, Bearings, Main shaft, Flybar, Spindle, Tail boom and support, Fins, Tail rotor shaft, Belt, Main blades and tail blades, Motor, Speed control and the Battery.

OTHER ITEMS REQUIRED

RADIO SET



Transmitter
(with 90° or 140°
E-CCPM System)

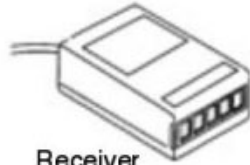

Receiver



Battery for
receiver



Switch harness

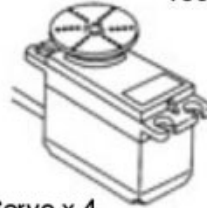

Servo x 4
(one for rudder
especially)

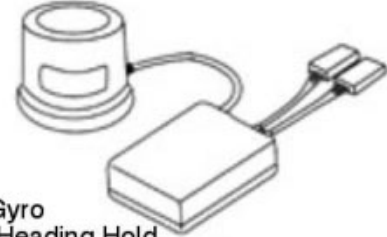

Gyro
(Heading Hold
Gyro is recommend)

ELECTRIC POWER SET



Brushless Motor

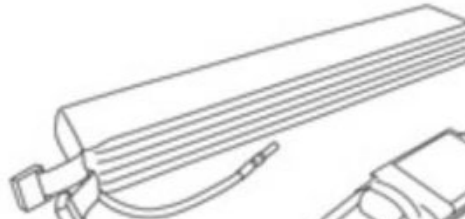

Li-Po Battery

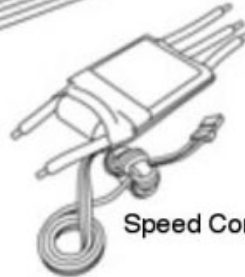

Speed Control

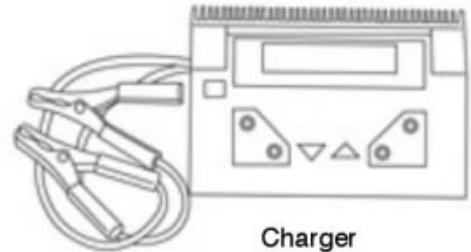

Charger

OTHERS



Velcro

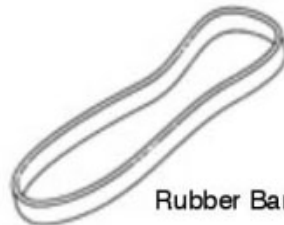

Rubber Band

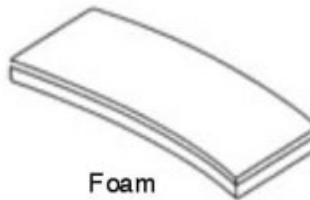

Foam

TOOLS REQUIRED FOR ASSEMBLY

Screw Driver



Needle Nose Pliers



5.5mm Wrench



7mm

Ball Link Pliers



Nipper



Scissors



Solder



Hobby Knife



Instant Glue



Blue Locktite

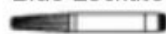

Grease



Solder Iron

Epoxy



Hex Wrench



5.5mm
7mm
8mm
10mm

Socket Drivers

ASSEMBLING SECTION

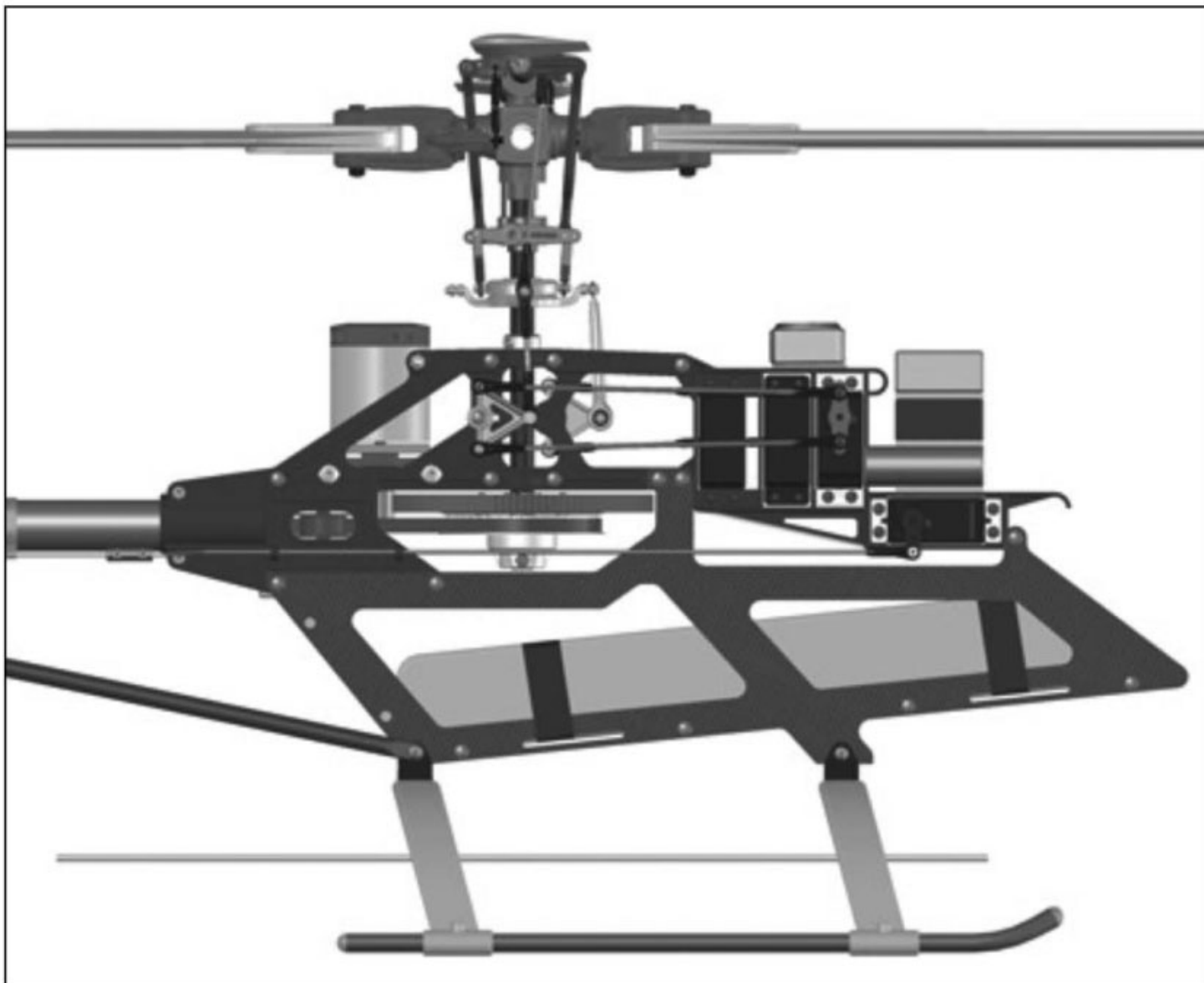

Most parts in the Raptor E Series kit are packed according to the assembly steps. The part number and quantity contained in each step are always shown in the square box on each page. Do not open all the bags at once. Open only the bag that is needed for the current assembly step.

① Main Frame Assembly-Part1

1. Complete the subassembly first.
2. Please install the frame spacers, bearings, pulleys and the elevator control lever between the frames according to the drawing below.
3. Secure the aileron control lever onto the side frame. You can use 90° or 140° E-CCPM with different mounting position of the aileron lever on the side frame. If you want to use 90° E-CCPM, please fit the aileron lever to the rear position. If you want to adopt 140° E-CCPM, please fit the aileron lever to the front position. (If you want to adopt the 140° E-CCPM, it is necessary to use the optional swashplate PV0566.)
4. Do not over tighten the self-tapping screws that could strip the plastic.

(1) BK1106 Servo Tray.....	1	(9) BK0076 Collar (ϕ 4x ϕ 3x10).....	2
(2) BK1104 Side Frame (Left).....	1	(10) BK0088 Washer (d3xd5x0.5).....	2
(3) BK1105 Side Frame (Right).....	1	(11) HSE3-12B Self-Tapping Screw (M3x12).....	12
(4) BK1111 Frame Spacer (44mm).....	9	(12) HMJ3-22B Self-Tapping Screw (M3x22).....	2
(5) BK0036 Pulley Collar.....	4	(13) 1-1 Elevator Control Lever Subassembly.....	1
(6) BK0081 Pin.....	2	(14) 1-2 Aileron Control Lever Subassembly (R)..	1
(7) BV0035 Guide Pulley.....	2	(15) 1-2 Aileron Control Lever Subassembly (L)..	1
(8) HVM6800ZZY Bearing (d10xD19xW5).....	2		

NOTE: Please refer to "Introduction of E-CCPM Control System" (P.22) for the detail of 90° / 140° E-CCPM system.

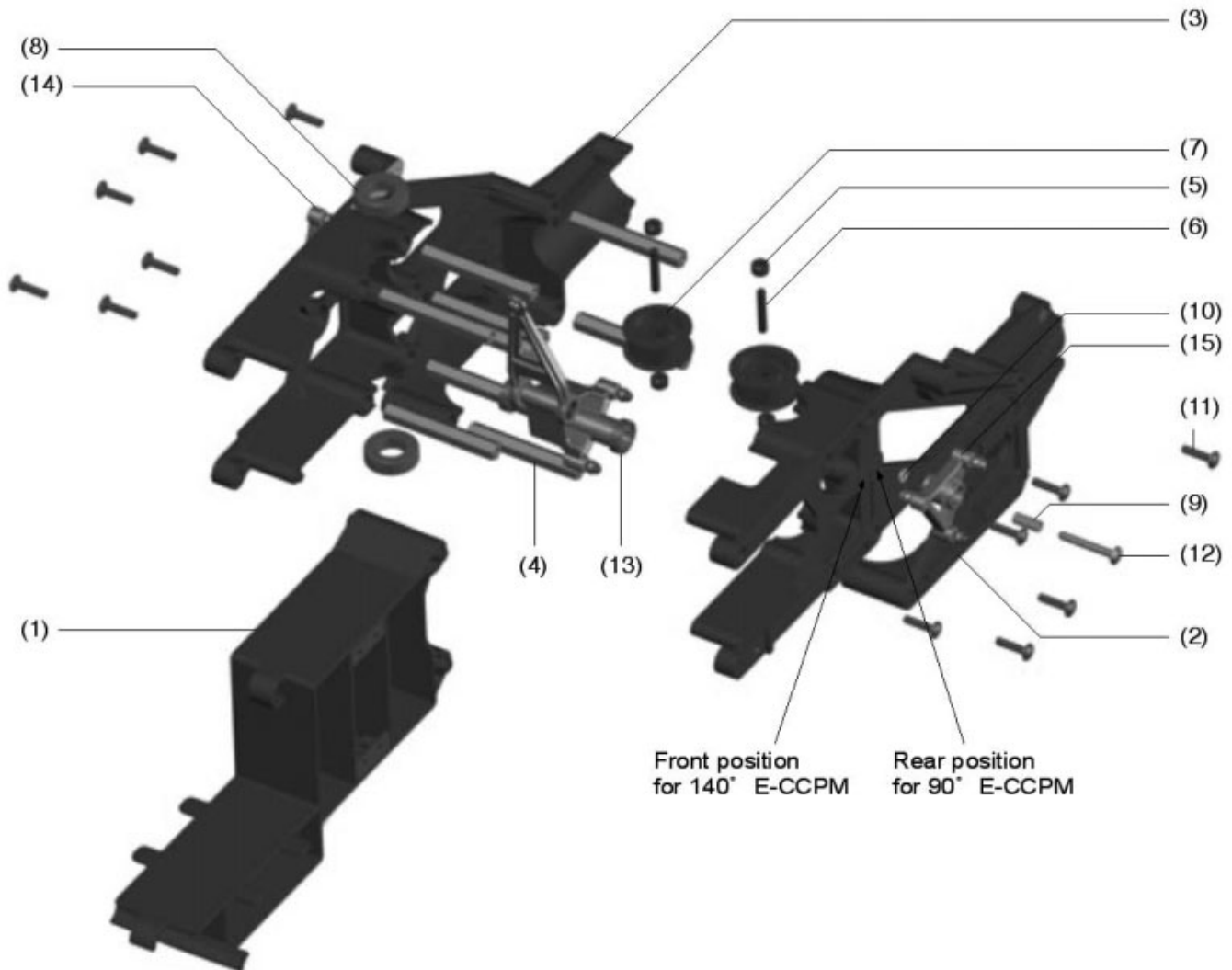

1-1 Elevator Control Arm Subassembly

- (1) BK1101 Elevator A Arm Link..... 1
- (2) BK1102 Elevator Control Arm..... 1
- (3) HMV740ZZY Bearing (d4xD7xW2.5)..... 2
- (4) BK1116 Collar (φ 4x φ 3x2.5)..... 2
- (5) HSE3-10B Self-Tapping Screw (M3x10)..... 2
- (6) HMJ2-10N Self-Tapping Screw (M2x10)..... 2
- (7) BK0075 Linkage Ball..... 2
- (8) HMV1280ZZY Bearing (d8xD12xW3.5)..... 2

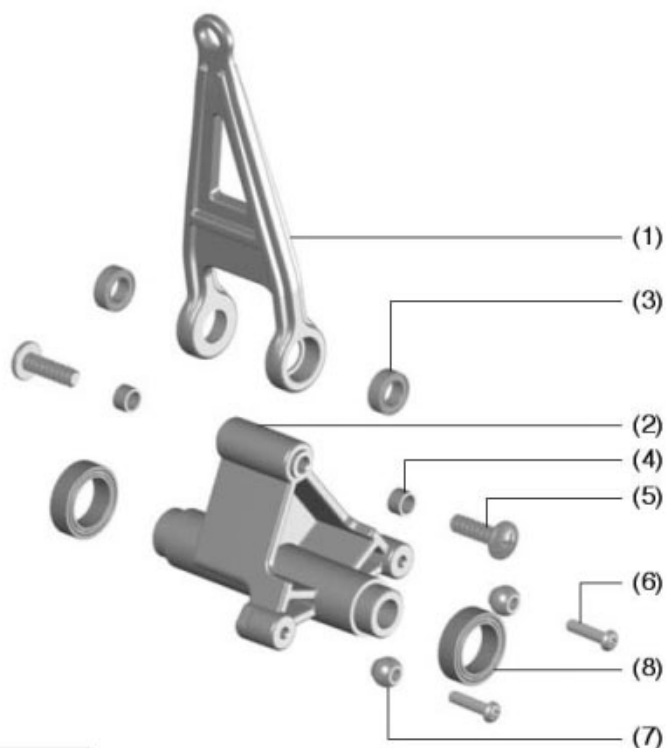

1-2 Aileron Control Lever Subassembly

LEFT

- (1) BK1103 Aileron Control Level..... 1
- (2) HMJ2-10N Self-Tapping Screw (M2x10)..... 3
- (3) BK0075 Linkage Ball..... 3
- (4) HMV740ZZY Bearing (d4xD7xW2.5)..... 2

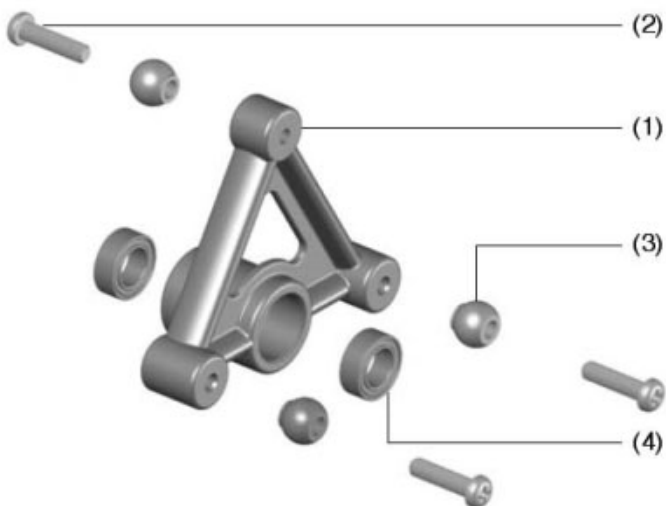

RIGHT

- (1) BK1103 Aileron Control Level..... 1
- (2) HMJ2-10N Self-Tapping Screw (M2x10)..... 3
- (3) BK0075 Linkage Ball..... 3
- (4) HMV740ZZY Bearing (d4xD7xW2.5)..... 2

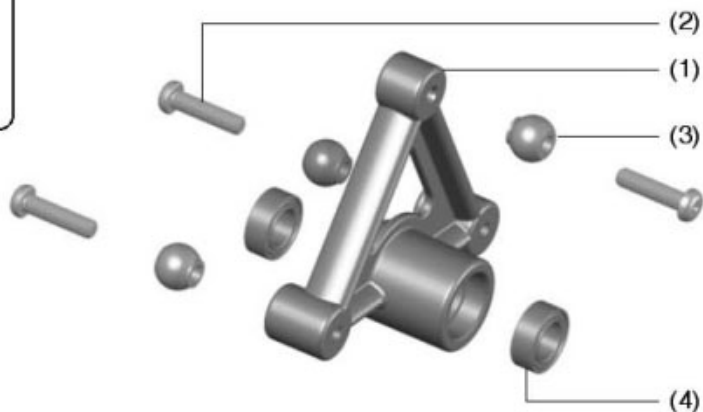

② Main Frame Assembly-Part 2

1. E620 SE adopt the lower carbon side frame instead of aluminum frame of E550.
2. Attach the rear landing skid adapter to the frame temporary, it has to be assembled with the tail support rod later.

(1) BK1107 Lower Carbon Side Frame (E620 SE).. 2	(8) HMJ3-22B Self-Tapping Screw (M3x22)..... 2
(2) BK1122 Lower Aluminum Side Frame (E550)....2	(9) BK0064T Skid Pipe..... 2
(3) BK1108 Base Plate..... 1	(10) BK0065 Skid Pipe End Cap..... 4
(4) BK1109 Back Plate.....1	(11) BK0066 Skid Brace..... 2
(5) BK1110 Landing Skip Adapter..... 4	(12) HME4-5B Set Screw (M4x5).....4
(6) BK1111 Frame Spacer (44mm).....2	(13) HSE3-18B Self-Tapping Screw (M3x18)..... 6
(7) HSE3-12B Self-Tapping Screw (M3x12)..... 16	

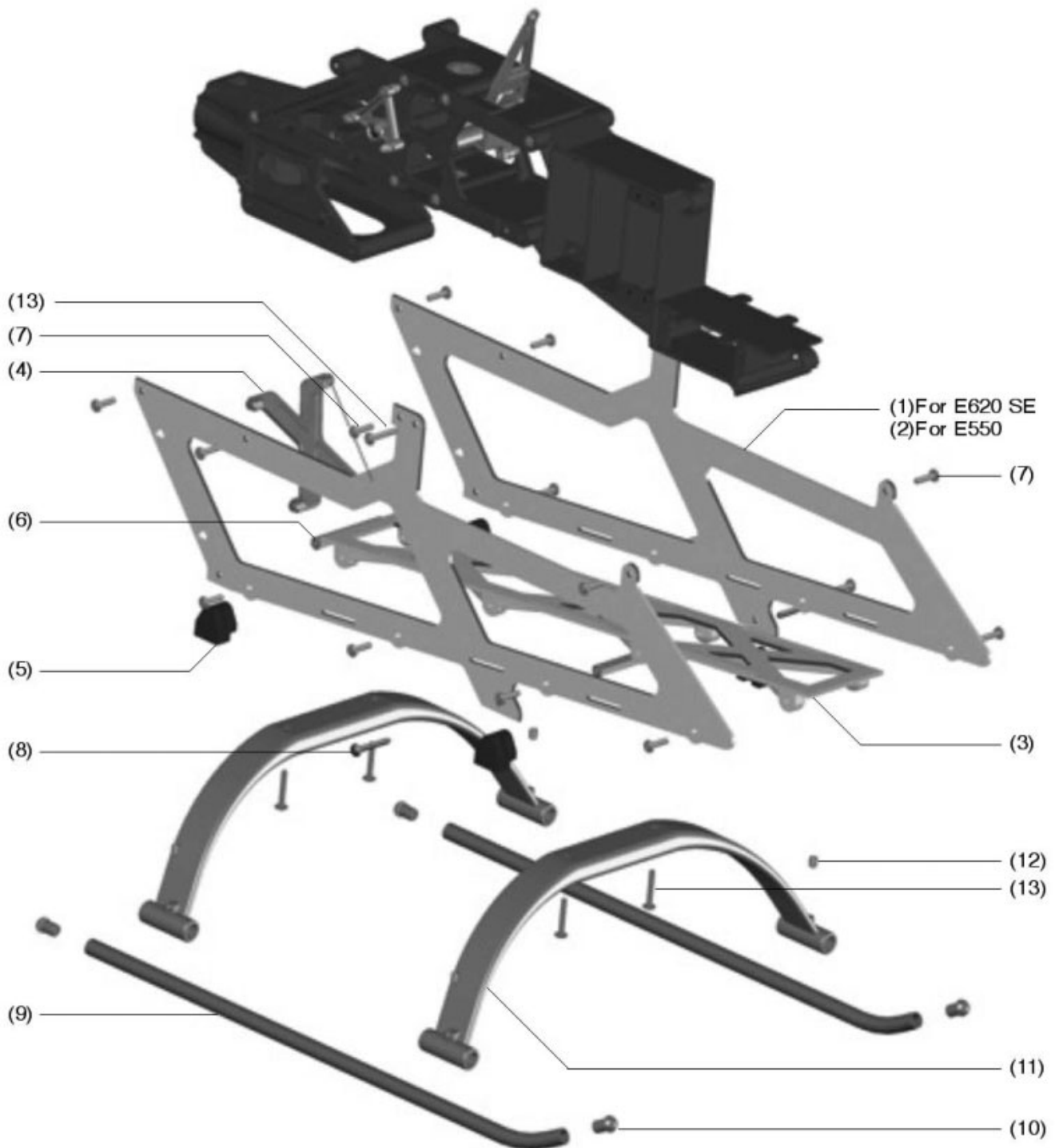

③ Main Drive Gear Assembly

It is necessary to add grease inside the one way clutch before your first flight. The one way clutch might lock up once grease is gone. The one way grease (PV0517) or ball differential grease is recommended for this lubrication.

- (1) HMC3-8B Socket Screw (M3x8).....4
- (2) HMQ14 Snap Ring..... 2
- (3) BV0033 One Way Clutch Housing..... 1
- (4) BK1112 Main Spur Gear 111T..... 1
- (5) BK0610 Autorotation Tail Drive Pulley..... 1
- (6) BK0034 One Way Clutch Shaft.....1



PV0517 ONEWAY BEARING GREASE

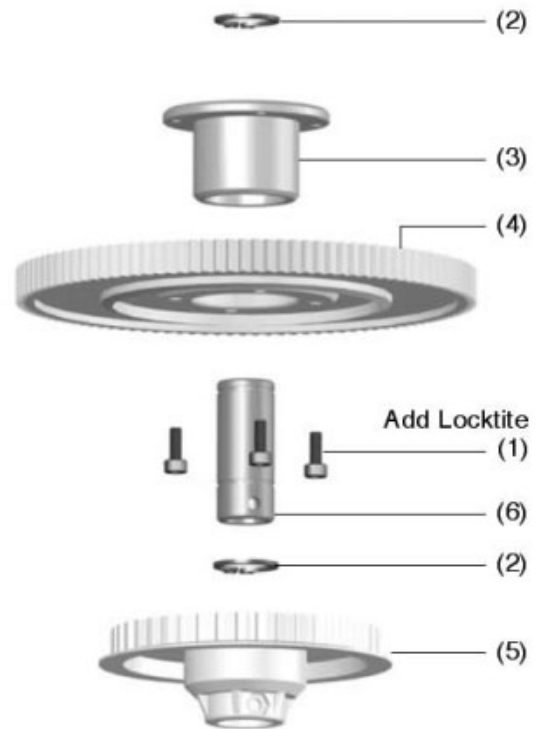

④ Washout Assembly

You can choose the position of the linkage ball. The outer hole would make it quicker, the inner hole would be smoother.

- (1) HMJ2-10N Self-Tapping Screw (M2x10)..... 2
- (2) HMC3-10B Socket Screw (M3x10)..... 2
- (3) HMV740ZZY Bearing (d4xD7xW2.5)..... 4
- (4) BK0077 Collar (φ 4x φ 3x6)..... 2
- (5) BK0171 Pin..... 2
- (6) BK0075 Linkage Ball..... 2
- (7) BK0015 Flybar Control Lever..... 2
- (8) BK0016 Washout Linkage..... 2
- (9) BK0014 Washout Base (E550)..... 1
- (10) BK0126 Metal Washout Base (E620 SE)..... 1
- (11) HMS15 E Ring..... 2
- (12) BK0088 Washer (E620 SE)..... 2

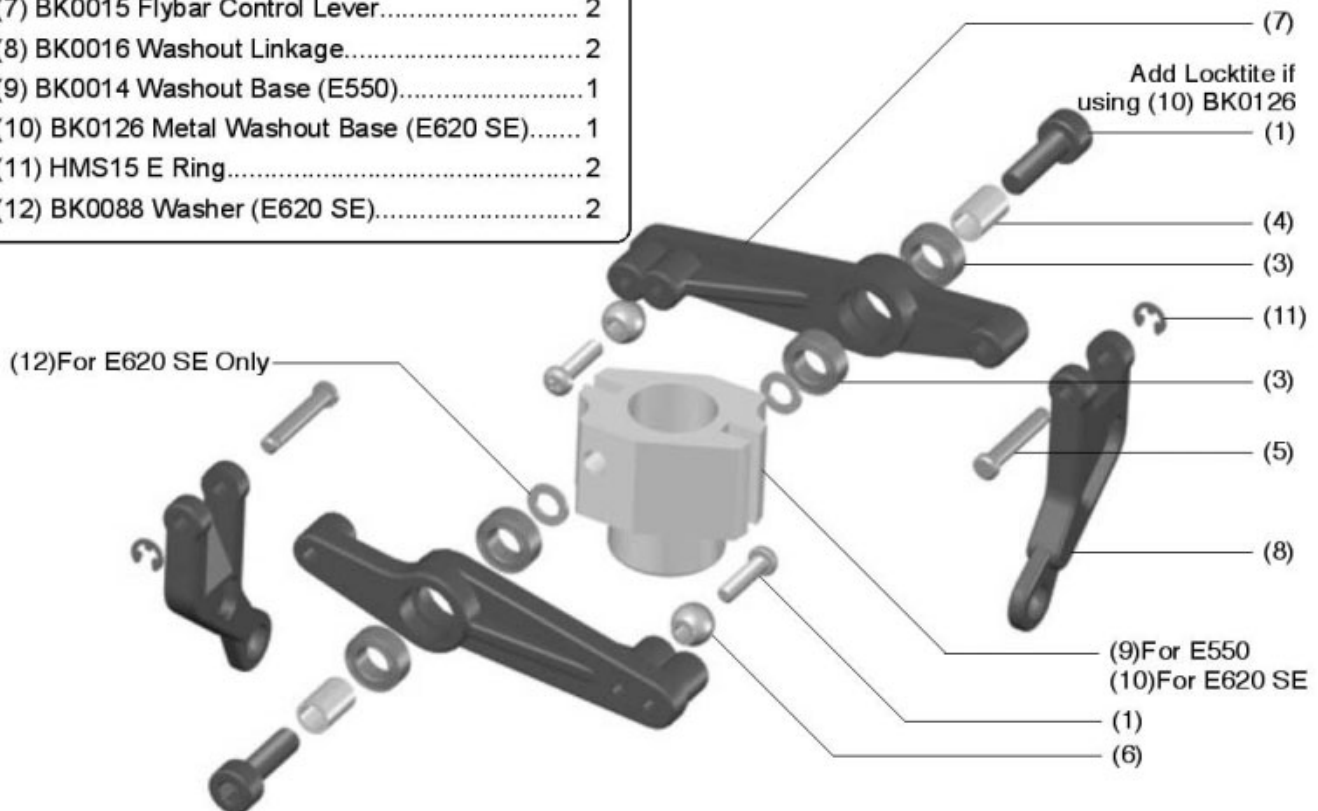

⑤ Main Frame Assembly-Part 3

1. Insert the main shaft through the shaft bearings. Make sure that the hole closer to the end is pointed down.
2. Slide the main gear assembly into the main frame and line up the hole in the main frame with the hole in the one way clutch shaft.
3. Insert the socket screw and secure it with a lock nut. You must not over tighten this screw or the one way would lock up easily.
4. Slide the main shaft lock ring, pull the main shaft upward and push the ring downward, then secure the ring with two set screws.
5. Slide the swashplate and attach the linkages to the balls of the outer swashplate.
6. Slide the washout assembly and attach the linkage to the balls of the inner swashplate.

(1) BK0616 Socket Screw (M3x20).....	1
(2) HMM3Z Lock Nut (M3).....	1
(3) HME4-5B Set Screw (M4x5).....	2
(4) BK0086 Ball Link.....	4
(5) BK0839 SUS Linkage Rod.....	2
(6) BK0030 Main Shaft Lock Ring.....	1
(7) BK0702 Harden Main Shaft.....	1
(8) BV0092 Metal Swashplate Assembly (E620 SE)...	1
(9) BV0601 Swashplate Assembly (E550).....	1
(10) Washout Assembly.....	1
(11) Main Gear Assembly.....	1

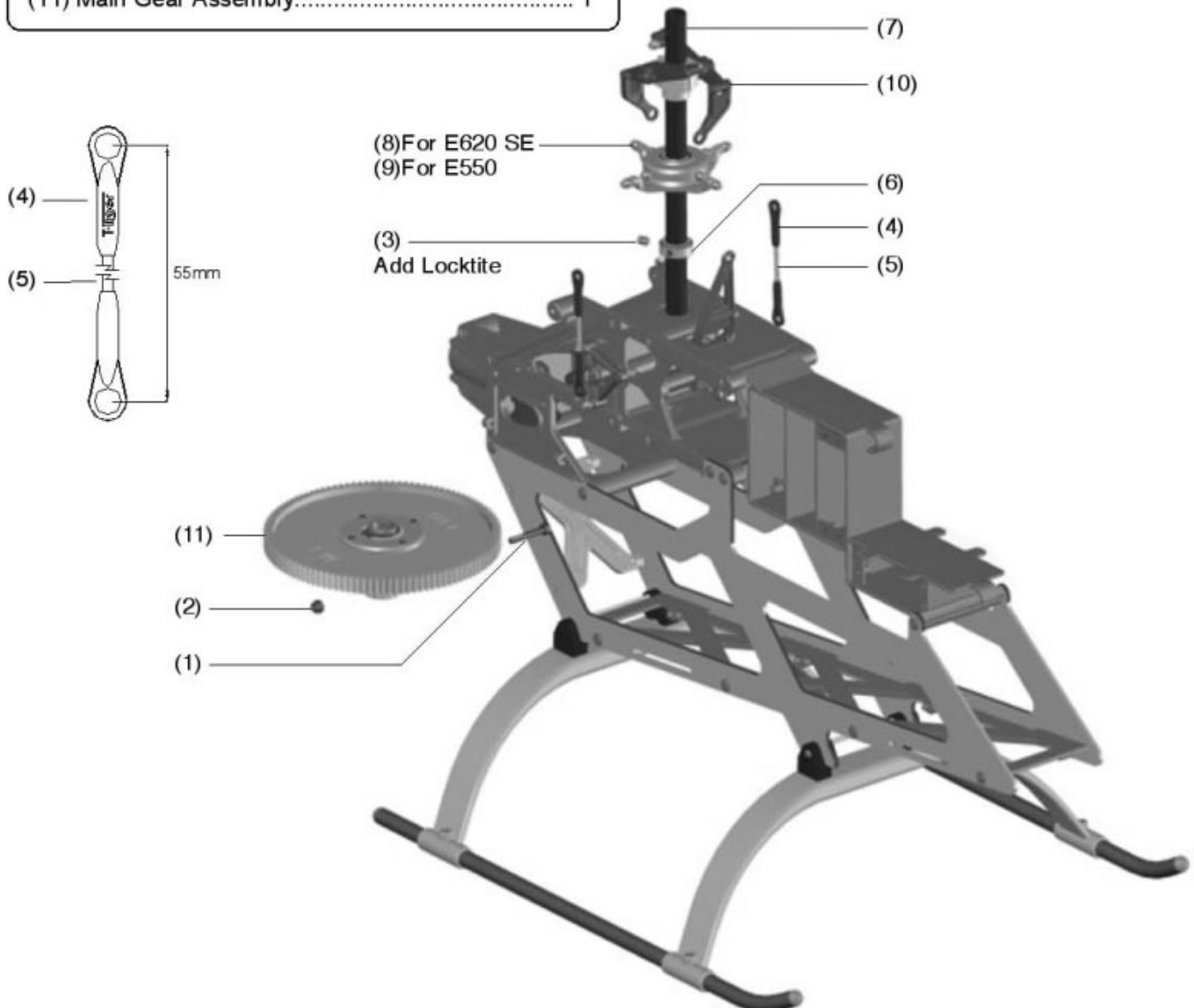

⑥ Main Frame Assembly-Part 4

1. Secure the pinion to the shaft of the motor with 2 set screws.
2. Mount the motor to the motor mount.
3. Attach the motor and motor mount to the upper chassis, adjust the gear mesh and secure the motor mount on the chassis.
4. The TT OBL 43/11-30H(No.2379) motor and 10T pinion are recommended for E550/E620 SE with 6S battery setup.
5. The TT OBL 49/08-50H(No.2380) motor and 9T pinion are recommended for E620 SE with 10S battery setup.

(1) Bk1114 Motor Mount.....	1
(2) BK1117 Drive Gear (Pinion 10T For E550).....	1
(3) BK1124 Drive Gear (Pinion 9T For E620 SE)..	1
(4) HMC3-6B Socket Screw (M3x6).....	4
(5) HMC3-10B Socket Screw (M3x10).....	4
(6) BK0087 Flat Washer.....	4
(7) HME4-5B Set Screw (M4x5).....	3

NOTE: For TT OBL brushless motors, only use two (4) HMC3-6B to mount the motor.

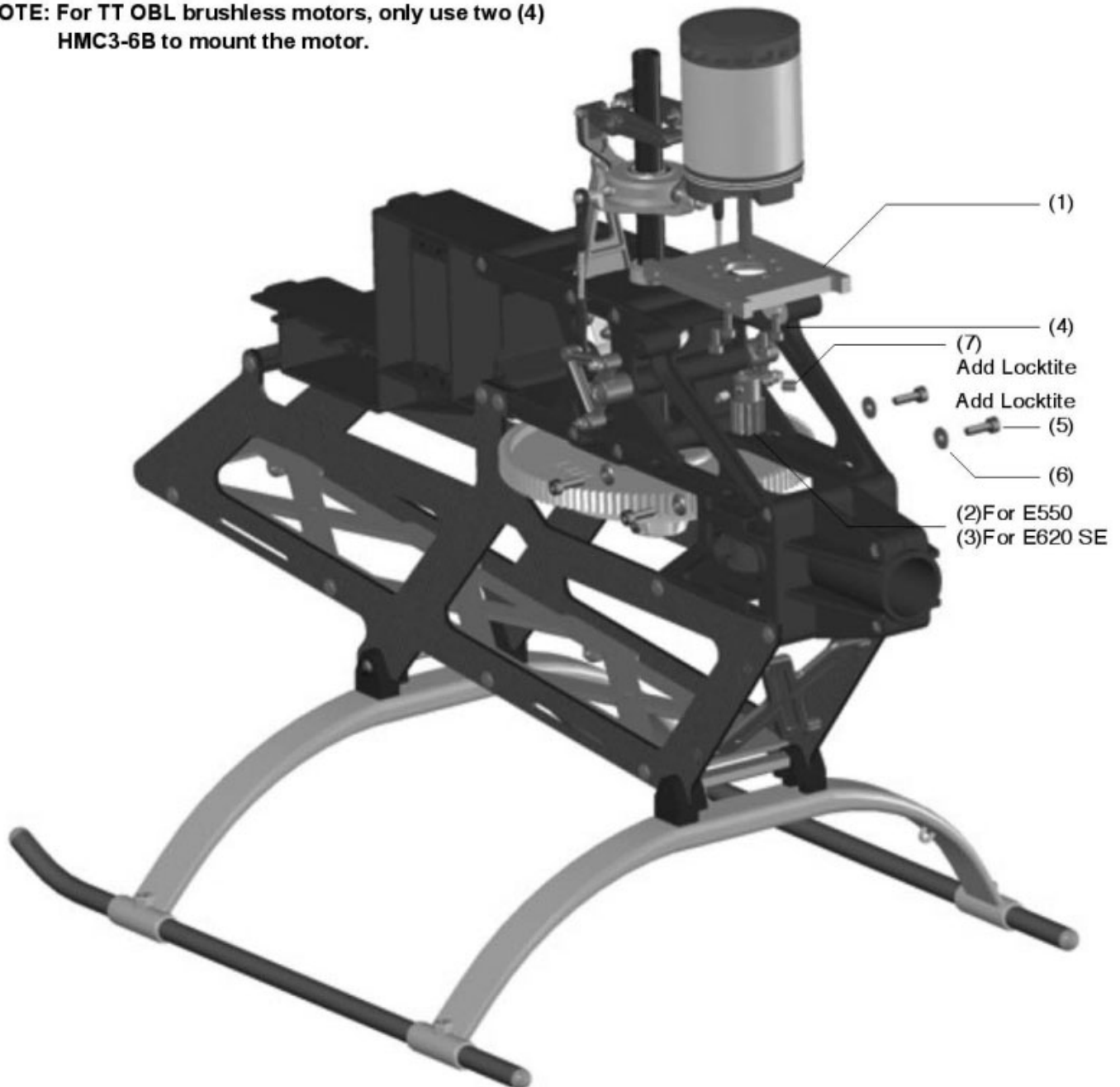

⑦ Main Rotor Head Assembly

1. Secure the linkage ball on the main rotor pitch housing.
2. Insert the flap damper in the main rotor hub.
3. Add silicon oil or vaseline to insert the feathering shaft through the dampers.
4. Be sure to apply loctite on the (16) M4x8 socket screw.
5. For E620 SE, do not tighten the (20) HMC2610B at this step.

(1) BK0012 Pin (E550).....	2	(12) BK0007 Flybar Control Rod.....	2
(2) HMY2-26 Pin (E620 SE).....	2	(13) BK0587 Main Rotor Hub Pin.....	1
(3) BK0435 Washer (d4xD11xW1.7).....	2	(14) BK0595 Main Rotor Hub (E550).....	1
(4) HMV1360ZZY (d6xD13xW5).....	4	(15) BK0554 Metal Main Rotor Hub (E620 SE).....	1
(5) BK0584 Thrust Washer.....	2	(16) HMC4-8B Socket Screw (M4x8).....	2
(6) HMX0612 Thrust Bearing.....	2	(17) BK0075 Linkage Ball.....	2
(7) BK0596 Main Rotor Pitch Housing.....	2	(18) HMJ2-10N Self-Tapping Screw (M2x10).....	2
(8) BK0583 Feathering Shaft.....	1	(19) BK0555 Phase Adjustment Ring (E620 SE).....	1
(9) BK0581 Flap Collar.....	2	(20) HMC2610B Socket Screw (M2.6x10)(E620 SE)....	1
(10) BK0586 Flap Damper (70°)(E550).....	2	(21) HMV6800ZZY Bearing (d10xD19xW5)(E620 SE). 2	
(11) BK0585 Flap Damper (80°)(E620 SE).....	2		

NOTE: For 3D flying, we strongly recommend the hard damper (PV0382) as well as the metal main rotor hub (PV0338 or PV0484).

(6) HMX0612

Large Internal Diameter—
always go toward the
Main Rotor Hub



Small Internal Diameter—
always go toward the
Blade

Diagram for Thrust Bearing Assembly

E550

Add Grease

(6)

(5)

(4)

(3)

(16)

Add Locktite

(10)

(9)

(4)

(8)

(7)

(17)

(18)

(14)

(12)

(13)

(1)

(15)

(12)

E620 SE

Add Grease

(6)

(5)

(4)

(3)

(16)

Add Locktite

(11)

(9)

(4)

(8)

(7)

(17)

(18)

(15)

(12)

(21)

(13)

No Locktite(20)

(19)

(2)

⑧ Flybar Assembly

1. Secure the 6 linkage balls to the flybar control arms and mixing levers with (17) HMJ2-10N Self-Tapping Screw (M2x10).
2. Assemble the seesaw hub, flybar, flybar arm bushing and the flybar control arm as drawing. Make sure the flybar has equal protruding from each side of the seesaw hub, then install and tighten the set screw (16) with locktite.
3. Add the paddles, equal the length from the paddle to the seesaw hub of each side. Parallel the paddles and the flybar control arms, then lock the paddles with the set screw (15).
4. Secure the mixing arms to the seesaw hub with locktite. Don't let the locktite seep into the bearings.
5. Connect the mixing lever (short side) to the main grip with the double link.

(1) BK0002 Flybar Control Arm.....	2	(11) BK0631 SUS Flybar.....	1
(2) BV0004 Flybar Seesaw Hub.....	1	(12) BV0085 Double Link.....	2
(3) BK0005 Flybar Arm Bushing.....	2	(13) HMC3-14B Socket Screw (M3x14).....	2
(4) BK0006 Mixing Lever.....	2	(14) HMC3-8B Socket Screw (M3x8).....	2
(5) BK0067 Flybar Paddle (E550).....	2	(15) HME3-10B Set Screw (M3x10).....	2
(6) BK0067G Ultra Light Paddle (E620 SE).....	2	(16) HME4-5B Set Screw (M4x5).....	2
(7) BK0075 Linkage Ball.....	6	(17) HMJ2-10N Self-Tapping Screw (M2x10).....	6
(8) BK0076 Collar (d3xD4x10).....	2	(18) HMV740ZZY Bearing (d4xD7x2.5).....	4
(9) BK0078 Collar (d3xD4x4).....	2	(19) HMV840ZZY Bearing (d4xD8x3).....	2
(10) BK0088 Washer (d3xD5x0.5).....	2	(20) Main Rotor Head Assembly.....	1

NOTE: 1.Black paddle (PV0036) is good for stable flying.

2.Light paddle (PV0481/25g or PV0482/20g) is recommended for 3D.

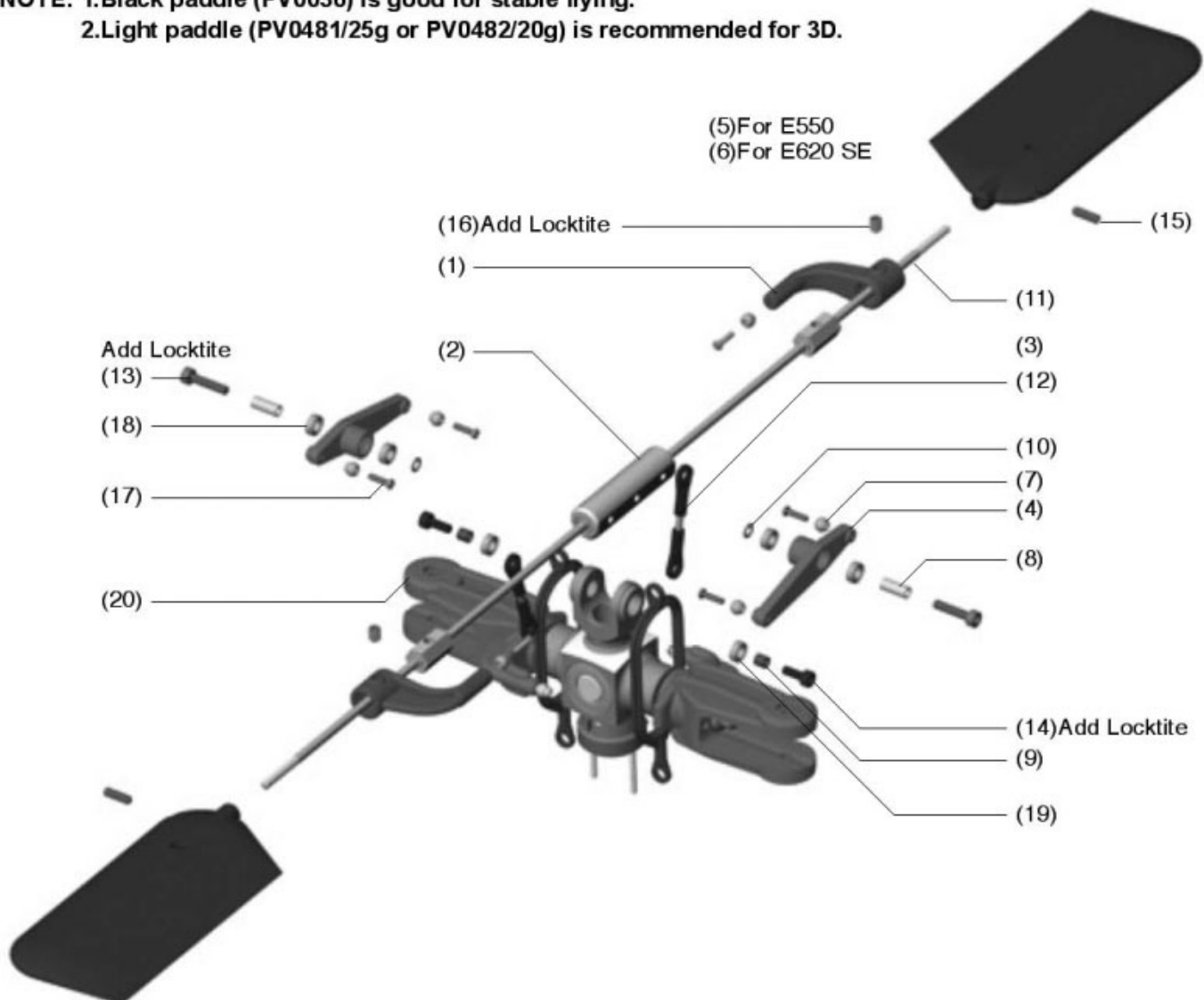

⑨ Main Frame Assembly-Part 5

1. Slide the main rotor assembly over the main shaft and align the two pins to slide in the washout assembly.
2. Insert the M3x20 socket screw and secure it with the lock nut.
3. Attach the rods to the long end of the mixing lever and to the balls of the inner swashplate.

(1) BK0616 Socket Screw (M3x20).....	1
(2) HMM3Z Lock Nut (M3).....	1
(3) HME3-18.5B Set Screw (M3x18.5).....	2
(4) BK0842 SUS Linkage Rod (M2.3x76).....	2
(5) BK0086 Ball Link.....	4
(6) BK0626 Canopy Retaining Post.....	2
(7) Main Rotor Head Assembly.....	1

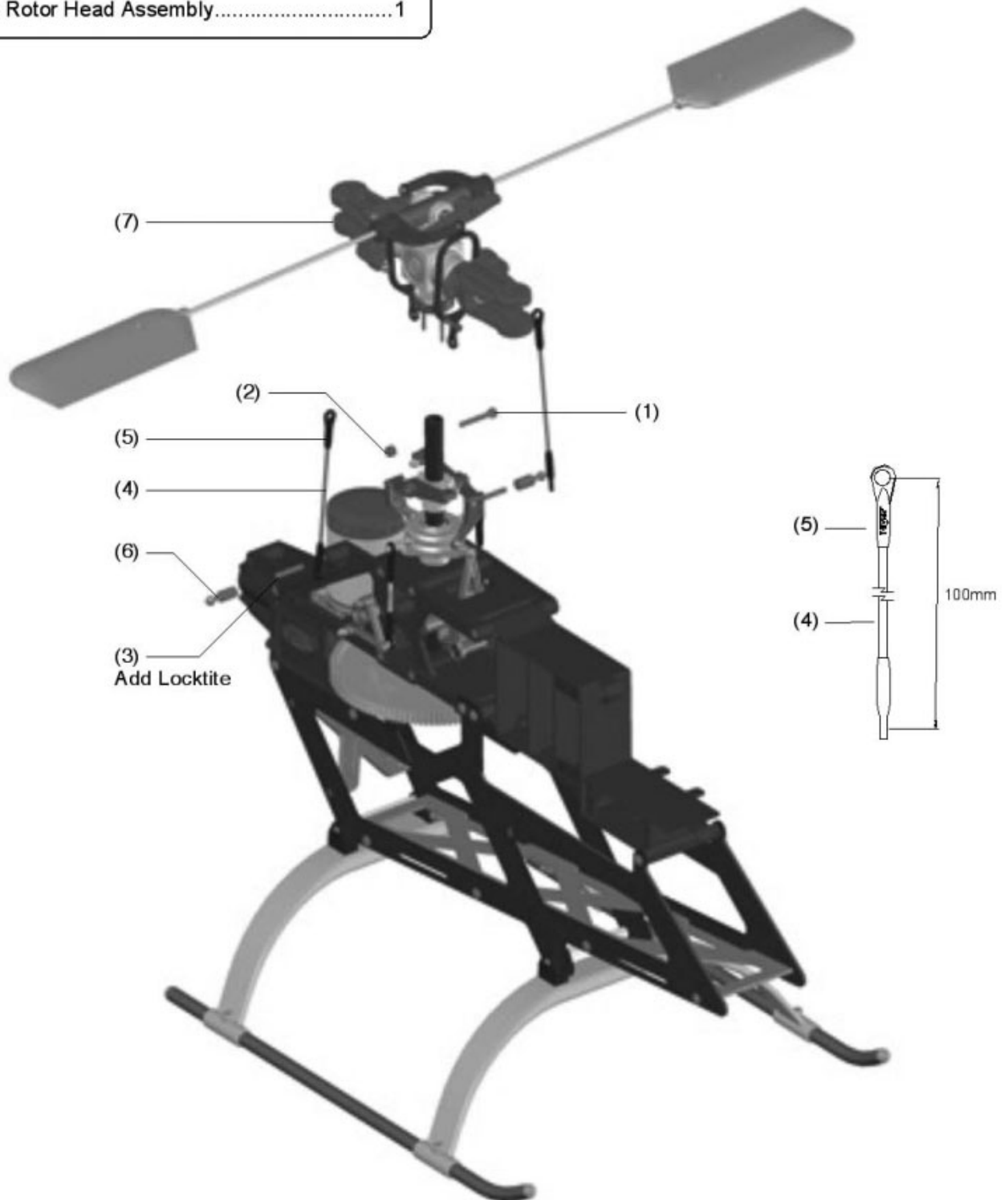

10 Tail Unit Assembly-Part 1

1. Secure the tail rotor hub on tail rotor shaft. The set screws should be right set on the dot of the shaft.
2. Do use locktite on the set screw(3).
3. Do not over tighten the lock nut (4).
4. Do not over tighten the self-tapping screw (2).The tail pitch control link should rotate freely.
5. Do not over tighten the fork and the bushing, it should rotate freely and move smoothly along the shaft.

(1) HMC2510B Socket Screw (M2.5x10).....	4	(11) BK0307 Tail Rotor Hub.....	1
(2) HSE2-10B Self-Tapping Screw (M2x10).....	2	(12) BK0026 Tail Pitch Control Link.....	2
(3) HME3-18.5B Set Screw (M3x18.5).....	2	(13) BK0025 Tail Pitch Fork.....	1
(4) HMM3Z Lock Nut (M3).....	2	(14) BK0027 Tail Pitch Control Slider.....	1
(5) HMV1050ZZ Bearing (d5xD10xW4).....	4	(15) BK0028 Tail Pitch Control Slider Bushing.....	1
(6) HMV1060ZZY Bearing (d6xD10xW3).....	2	(16) BK0053 Tail Rotor Shaft.....	1
(7) BK0082 Collar (d2xD3xW4.3).....	2	(17) HMM25 Lock Nut (M2.5).....	4
(8) BK0546 Pin (2mm).....	2	(18) BK0075 Linkage Ball.....	1
(9) BK0302-1 Tail Pitch Housing (A).....	2	(19) HMF2-8N Screw (M2x8).....	1
(10) BK0303-1 Tail Pitch Housing (B).....	2	(20) HMS15 E Ring.....	4

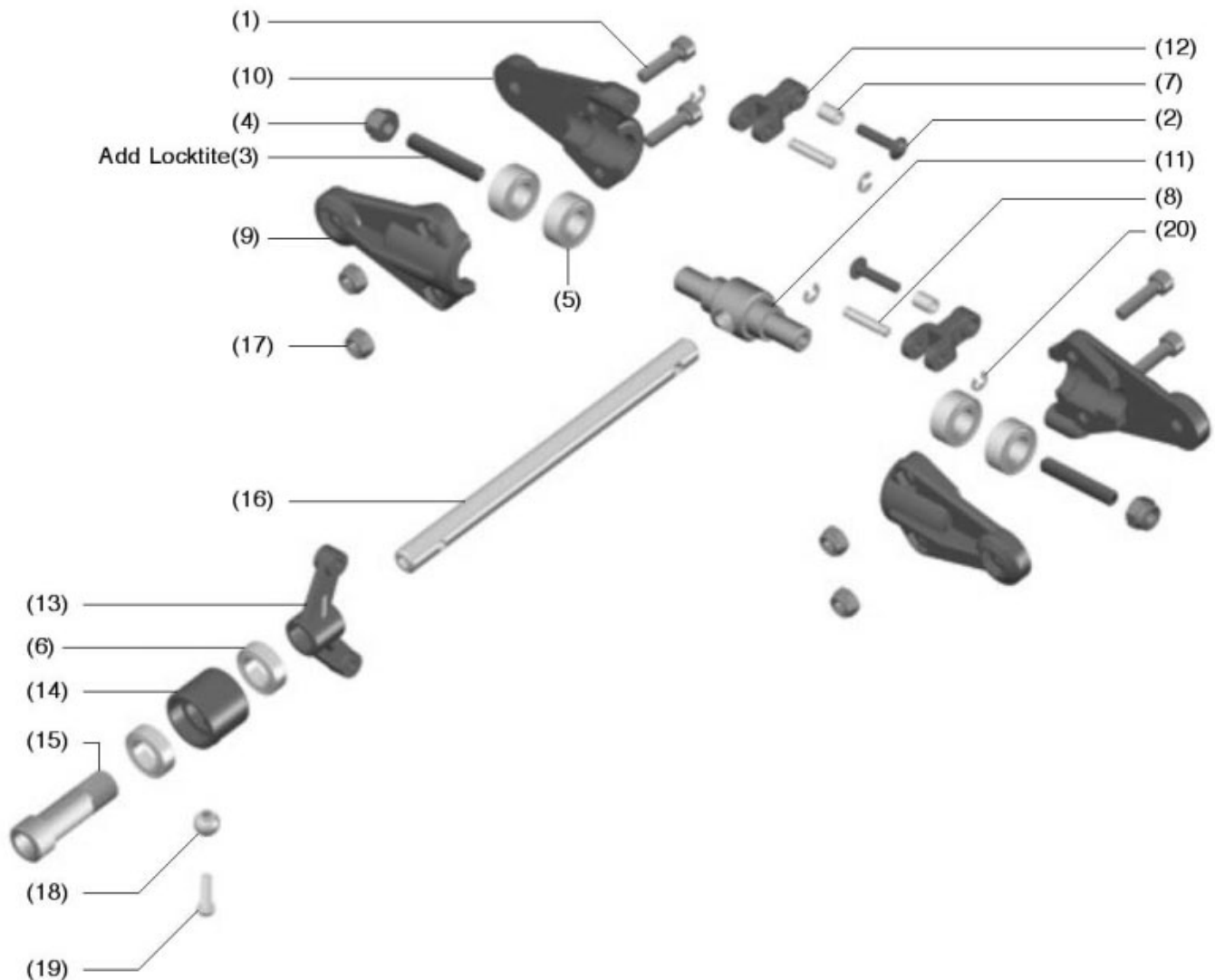

11 Tail Unit Assembly-Part 2

1. Secure the pulley by pressing the pin into the tail shaft.
2. Do apply loctite on the set screw and secure the pin firmly.
3. Do not over tighten the tail pitch control lever. It should rotate freely or the tail will be hard to control while flying.

(1) HMV1150X Bearing (d5xD11xW5).....	1	(8) BK0024 Tail Pitch Control Lever.....	1
(2) HMY2-12 Pin (2x12).....	1	(9) BK0088 Flat Washer.....	1
(3) HSE3-18B Self-Tapping Screw (M3x18).....	1	(10) HME3-4B Set Screw (M3x4).....	1
(4) HMF2-8N Screw (M2x8).....	1	(11) BK0050 Tail Pulley.....	1
(5) BK0076 Collar (d3xD4xW10).....	1	(12) BK0051 Tail Pulley Flange.....	1
(6) BK0075 Linkage Ball.....	1	(13) BK0047 Tail Unit Housing (R).....	1
(7) HMV740ZZY Bearing (d4xD7xW2.5).....	2	(14) Tail Unit Assembly.....	1

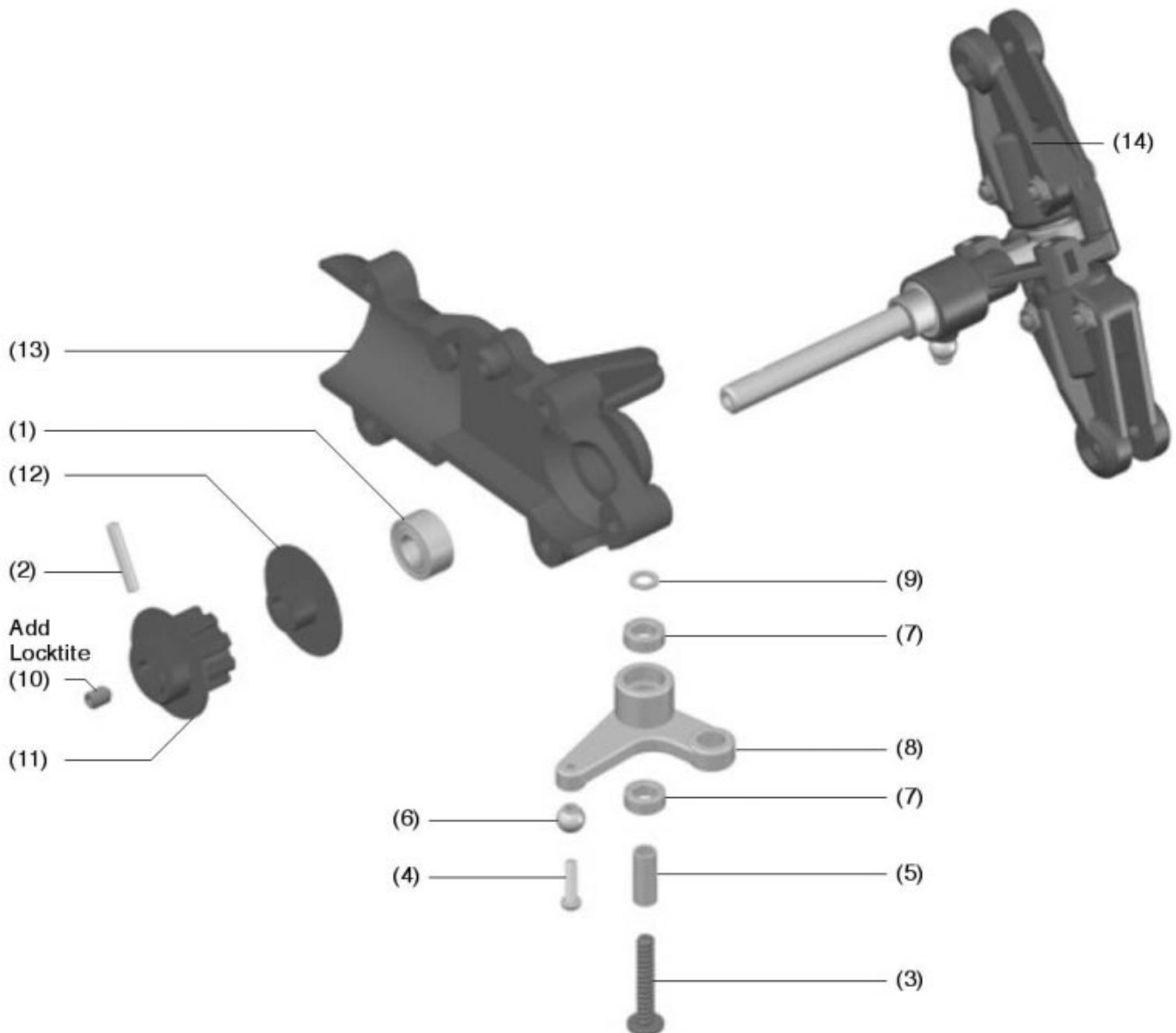

12 Tail Boom Assembly

1. Slide the 3 rod guides onto the boom and space them out evenly.
2. Slide the tail linkage rod into the rod guides.
3. Insert the tail rod drive belt into the boom so that it comes out of both ends.
4. Place drive belt over tail drive pulley and complete balance of tail boom assembly.
5. Apply thick CA or Epoxy when installing the Tail Support Rod End.

(1) HMC3-20B Socket Screw (M3x20).....	4	(14) BK0524T Tail Support Rod (E620 SE).....	2
(2) HMC3-25B Socket Screw (M3x25).....	2	(15) BK0060-T Tail Boom (E550).....	1
(3) HSE3-12B Self-Tapping Screw.....	4	(16) BK0859 Tail Boom (E620 SE).....	1
(4) HMM3Z Lock Nut (M3).....	6	(17) BK0091 Rod Guide.....	3
(5) H MV1150X Bearing (d5xD11xW5).....	1	(18) BK0089 Tail Rotor Drive Belt (E550).....	1
(6) BK0046 Tail Unit Housing (L).....	1	(19) BK0858 Tail Rotor Drive Belt (E620 SE).....	1
(7) BK0071 Vertical Fin (E550).....	1	(20) BK0100-2 Tail Linkage Rod (E550).....	1
(8) BK0069 Stabilizer Fin (E550).....	1	(21) BK0861 Tail Linkage Rod (E620 SE).....	1
(9) BK0801 Carbon Vertical Fin (E620 SE).....	1	(22) BK0447 Tail Support Rod End.....	4
(10) BK0121 Carbon Stabilizer Fin (E620 SE).....	1	(23) HMJ2-8N Self-Tapping Screw (M2x8).....	4
(11) BK0809 POM Washer (d3xD10x3)(E620 SE).....	2	(24) BK0086 Ball Link.....	1
(12) BK0070 Stabilizer Fin Bracket.....	1	(25) BV0052 Tail Idle Pulley.....	1
(13) BK0540-T Tail Support Rod (E550).....	2	(26) Tail Unit.....	1

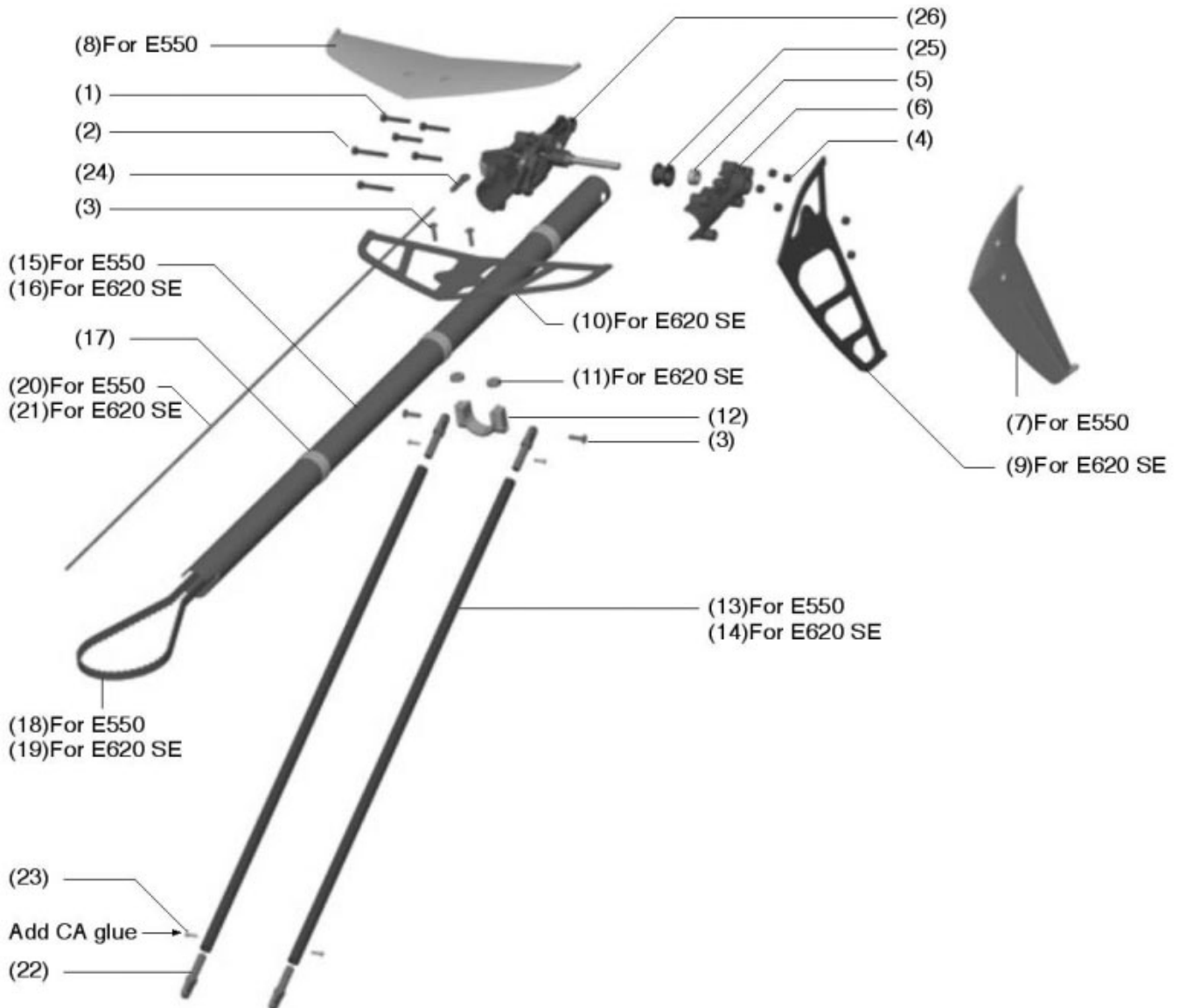

13 Main Frame Assembly-Part 6

1. Insert the M3x20 socket screw into the tail base of the main frame and secure them with lock nuts, but not tighten them yet.
2. The belt must be rotated as shown below. Pull the belt through the tail base, keeping the belt correctly aligned. Push the tail boom into the tail base all the way to the end. Place the drive belt over the tail drive spur gear. Then, gently pull back on the tail boom until the tension on the belt allows no more than 5mm(3/16") of free play in the belt. Tighten the locknuts and proceed with the rest of the assembly.
3. Assemble the tail push rod A and B. Please refer to P.34 to adjust the length.
4. For the E620 SE, please follow the setting tip to adjust the phasing.

- | | |
|--|---|
| (1) BK0068 Tail Rotor Blade..... | 2 |
| (2) HMJ3-22B Self-Tapping Screw (M3x22)..... | 2 |
| (3) HMC3-14B Socket Screw (M3x14)..... | 2 |
| (4) HMC3-20B Socket Screw (M3x20)..... | 2 |
| (5) HMM3Z Lock Nut (M3)..... | 4 |
| (6) HME4-5B Set Screw..... | 2 |
| (7) BK0105 Tail Control Rod Joint..... | 1 |
| (8) Bk1123 SUS Push Rod A..... | 1 |

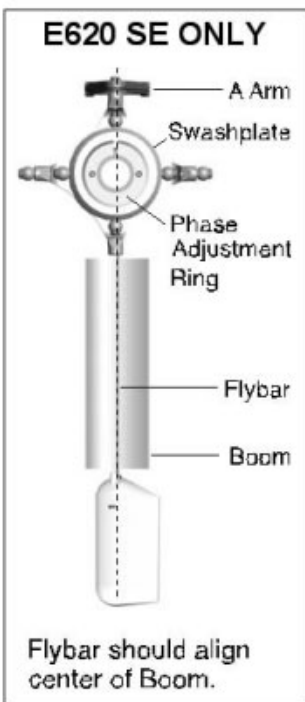
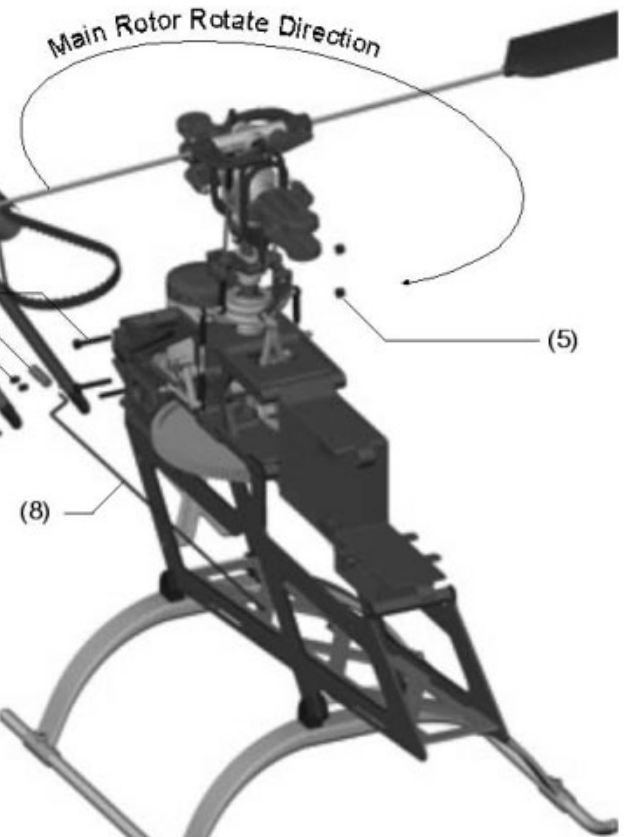
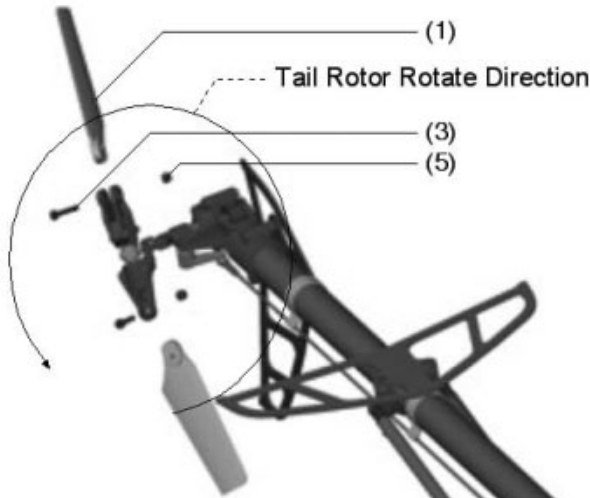
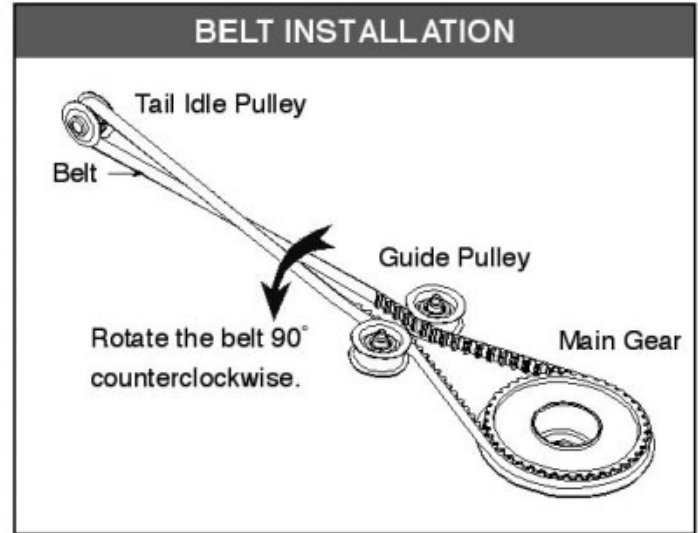

Tip: When setting up the phase adjustment ring, the flybar and the tail boom can be the reference. When the flybar and the tail boom are centered, the inner balls of swashplate should be aligned with the outer balls. Tighten the socket screw on the phase ring at this moment.

NOTE: Improper alignment will cause unwanted mixing.

14 Servo Installation-Part 1

1. Remove all the servo wheels prior to attaching the steel linkage balls.
2. Mount the linkage balls at 13.5mm from the center of the servo arm.
3. For rudder servo, please refer to the manual of your gyro to choose the length of the arm.
4. Make sure that the lengths of the linkages are correct.

(1) HSE2612N Self-Tapping Screw (M2.6x12).....	8
(2) BK0075 Linkage Ball.....	3
(3) BK0086 Ball Link.....	5
(4) BK0104 Servo Mount Plate.....	4
(5) BK1120 SUS Push Rod (M2.3x130).....	2
(6) HMF2-8N Screw (M2x8).....	3
(7) HML2 Nut (M2).....	3

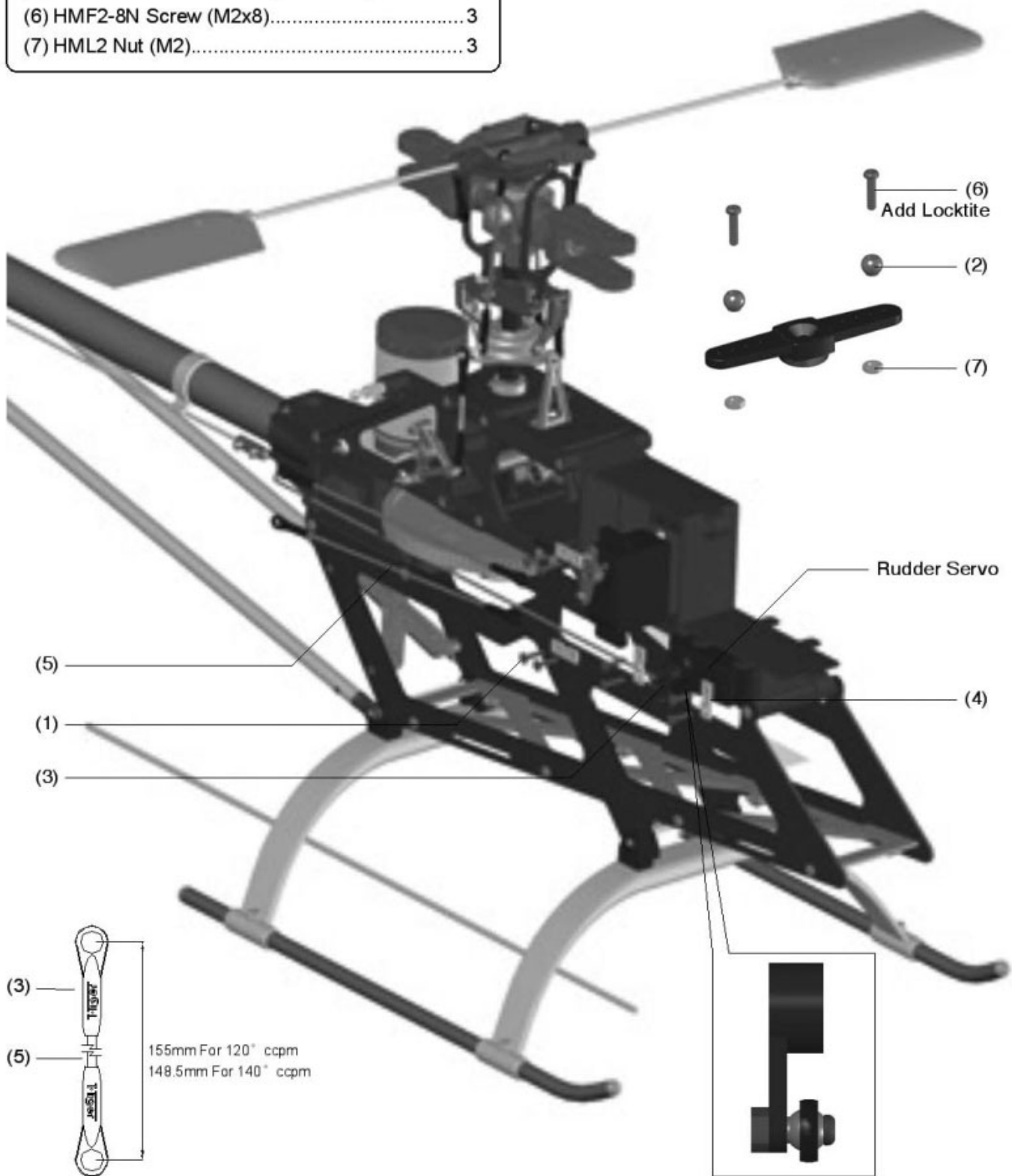

15 Servo Installation-Part 2

1. Remove all the servo wheels prior to attaching the steel linkage balls.
2. Mount the linkage balls at 13.5mm from the center of the servo arm.
3. Make sure that the lengths of the linkages are correct.

(1) HSE2612N Self-Tapping Screw (M2.6x12).....	8
(2) BK0075 Linkage Ball.....	4
(3) BK0086 Ball Link.....	8
(4) BK0104 Servo Mount Plate.....	4
(5) BK1121 SUS Push Rod (M2.3x107).....	2
(6) BK0840 SUS Push Rod (M2.3x46).....	2
(7) HMF2-8N Screw (M2x8).....	4
(8) HML2 Nut (M2).....	4

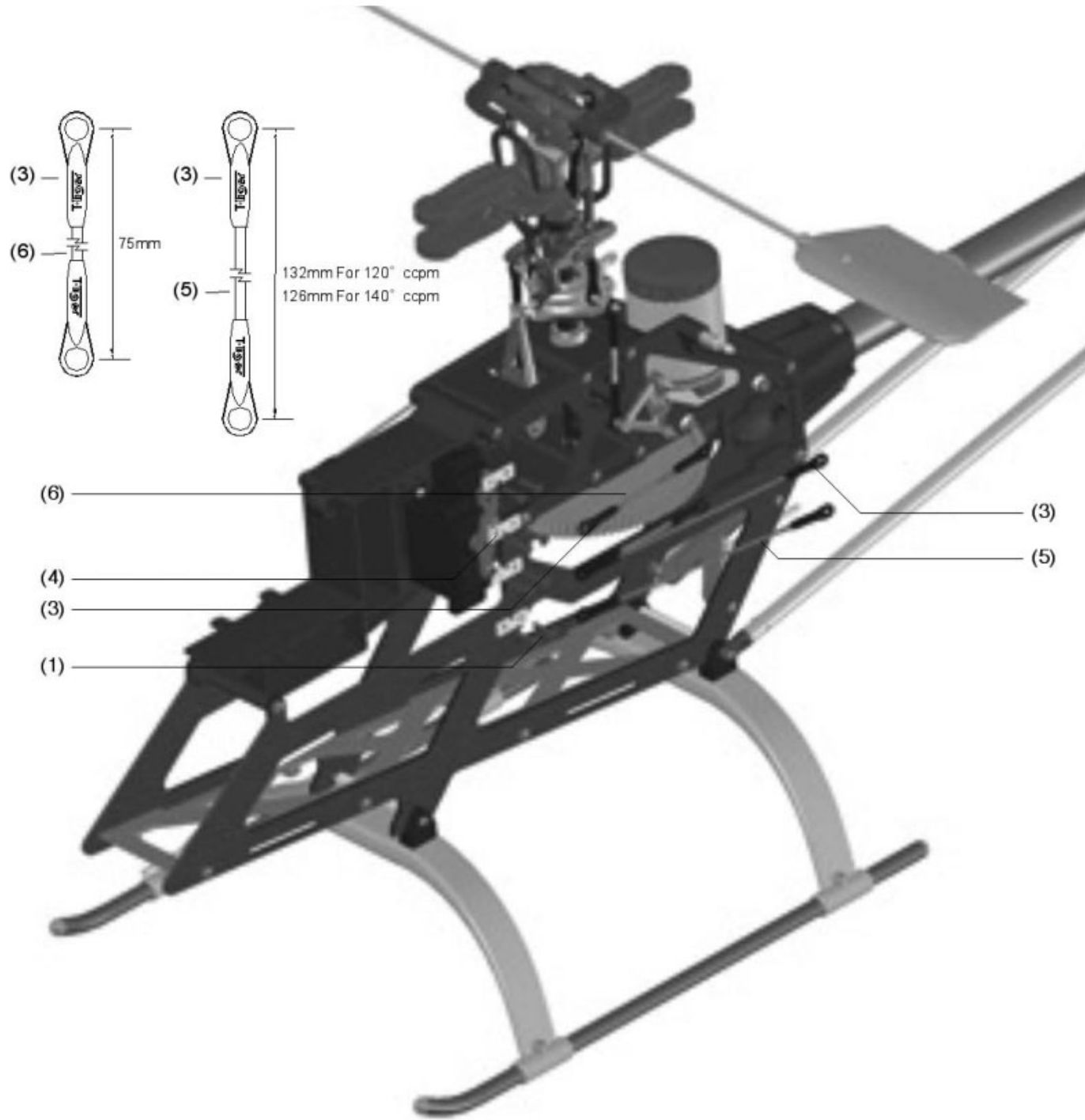
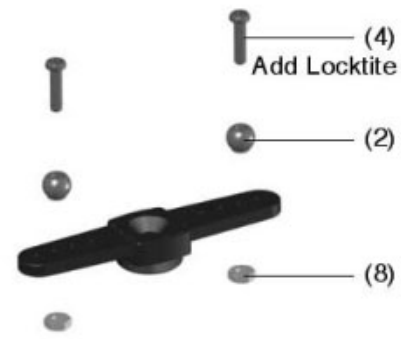

16 Receiver/Gyro Installation

Thunder Tiger recognizes that there are many brands of radios and gyros to choose from. You are encouraged to seek the advice of experienced helicopter pilots when making this decision.

- | | |
|----------------------------------|---|
| (1) BE1052 Antenna Tube..... | 1 |
| (2) BK0106 Double Side Tape..... | 2 |

Note:

1. It is strongly recommended to connect an anti-interference ring between the ESC and the receiver.
2. Do not set the antenna at the same side of the helicopter with the ESC and the battery wires.

Heading lock gyro is recommended

Gyro Amplifier

(2)

Receiver

(2)

Battery Pack

(2)

Li-Po Battery

Speed Control

Velcro

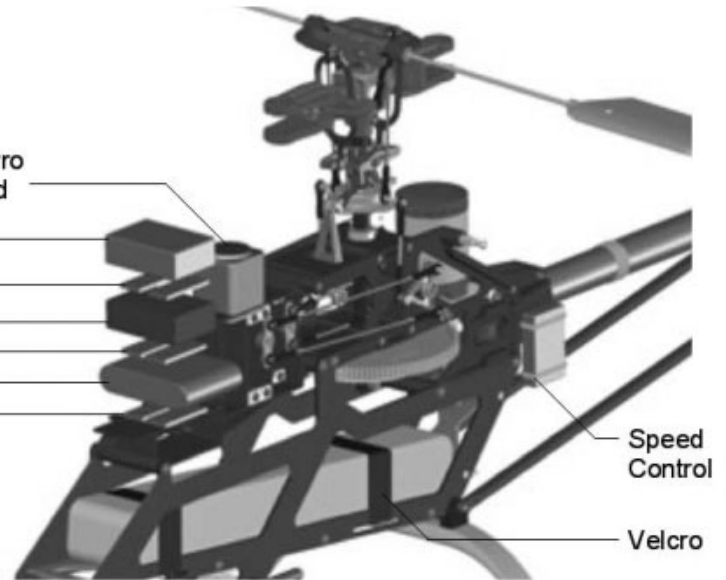

17 Body/Canopy Assembly

1. Cut off the bubble from the body. Leave the lip of the opening in the body that you can screw the canopy on it.
2. Cut off the flange in the rear of the body to avoid the main gear scratching it.
3. If the body falls out during flying, install the self-tapping screw on the clip-A.

- | | |
|--|---|
| (1) HMJ2-6B Self-Tapping Screw (M2x6)..... | 7 |
| (2) HSE3-12B Self-Tapping Screw (M3x12)..... | 2 |
| (3) BK0611 Body..... | 1 |
| (4) BK0102 Rubber Grommet..... | 2 |
| (5) BK0098 Body Clip-A..... | 1 |
| (6) BK0099 Body Clip-B..... | 1 |
| (7) BK0612 Canopy..... | 1 |

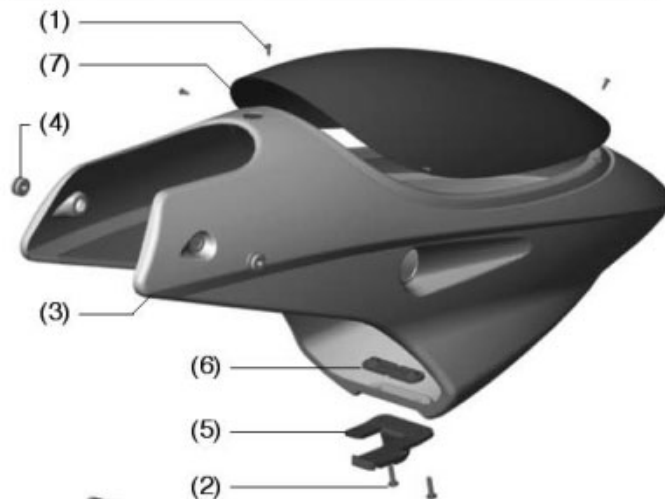

Body

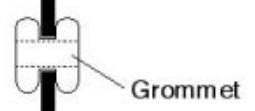

Grommet

Trim the hole and install the rubber grommets as shown.

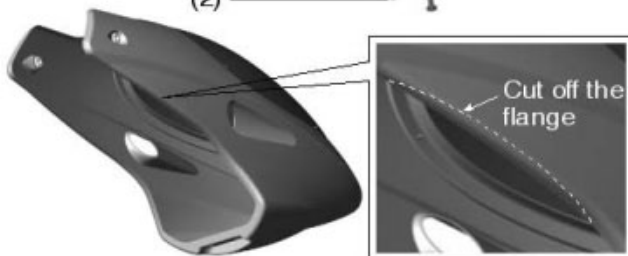

If the Body will fall out during backward 3D flying, we suggest to install the self tapping screw (#1) on Body Clip-A (#5).

18 Main Rotor Assembly

We strongly recommend using Fiberglass or Carbon rotor blades for safety and higher performance.

- | | |
|---------------------------------------|---|
| (1) HMC4-27B Socket Screw (M4x7)..... | 2 |
| (2) HMM4Z Lock Nut (M4)..... | 2 |

Note: Because the headspeed of an electric RC helicopter is very high, we strongly recommend to use Fiberglass or Carbon Fiber main blades.



INTRODUCTION OF E-CCPM CONTROL SYSTEM

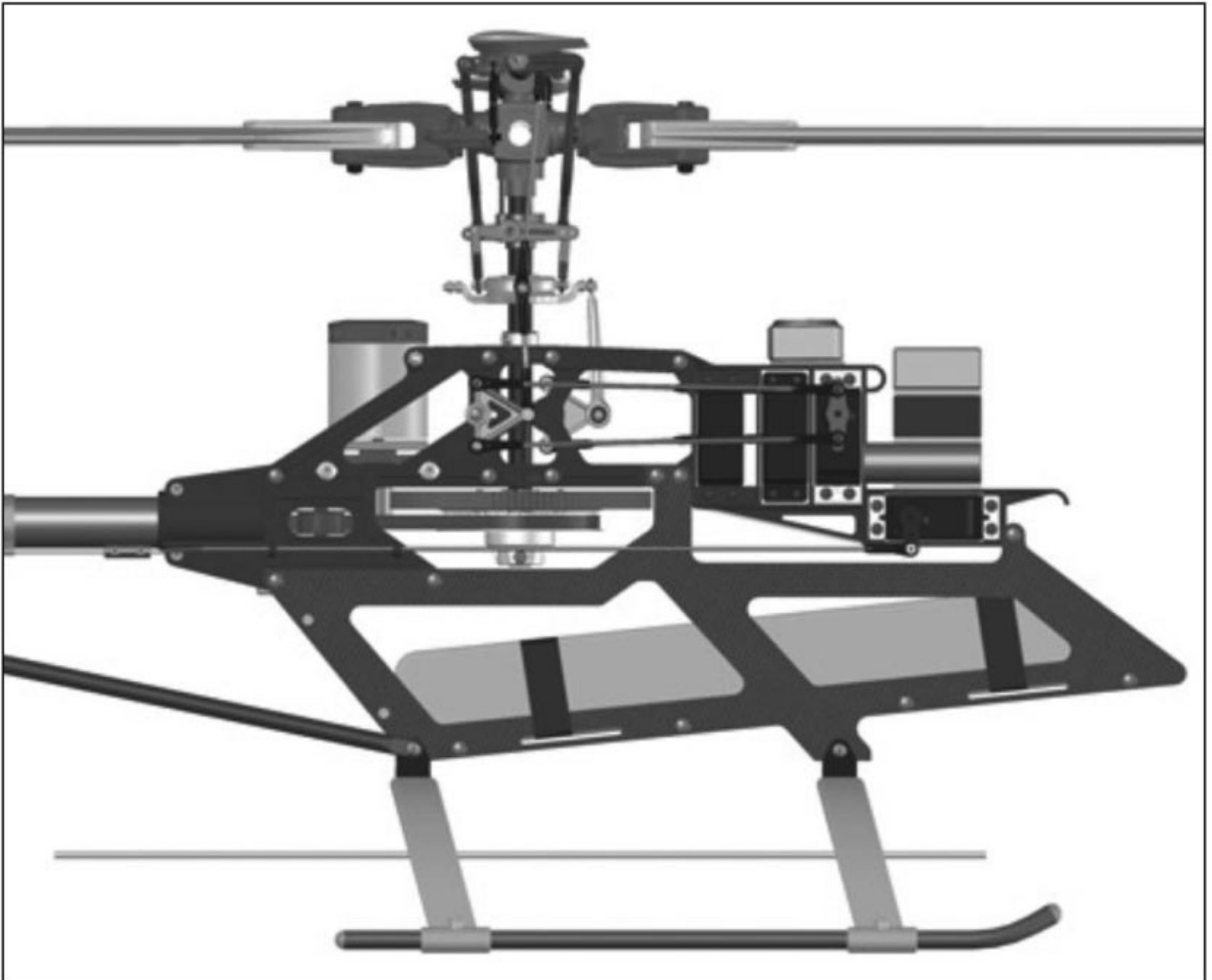

The E-CCPM (Electric Cyclic/Collective Pitch Mixing) system offers the users a control system that can accomplish the same control inputs as traditional M-CCPM (Mechanical Cyclic/Collective Pitch Mixing) system, but with simple machinery. The 90° /140° E-CCPM system utilizes 3 servos for the main control of aileron, elevator and collective pitch. The 3 servos work independently from each other of M-CCPM system, but they work as a team to achieve the same control of the E-CCPM system. For example, if a collective input is given, all of the 3 servos work together to move the swashplate up and down. If an aileron input is given, 2 servos work at the same time to make the swashplate inclined. With servos working together during any given command, the torque is maximized. In addition, E-CCPM system execute the given control inputs with less complex mechanical mixing systems and require less control rods and parts.

MOVEMENT OF 90°/140° E-CCPM SYSTEM

We adopt the 90°/140° E-CCPM system on the helicopter. You can choose whichever you like depending on your preference and your transmitter. The main difference is that only 1 servo works while elevator input is given if using 90° E-CCPM. But with 140° E-CCPM system, all the 3 servos work at the situation.

In today's modern computer radio system, the E-CCPM system is established in the program. Since the 90°/140° E-CCPM function are preprogrammed, there is no more complicated mixing/setup than the M-CCPM system. For the radio type and brand, please choose which has the 90°/140° E-CCPM function. Please note that it is not possible to use a non-E-CCPM radio system for E-CCPM operation.

The given inputs are executed by the team work of the 3 servos through the mixing program of the radio. The following are the examples showing how the movement be carried out.

■ COLLECTIVE PITCH

When a collective pitch command is given, all of the 3 servos move toward the same direction with same speed and same travel distance. This movement is to raise or lower the swashplate and keep the swashplate horizontal. Thus, the required collective pitch can be reached without cyclic input.

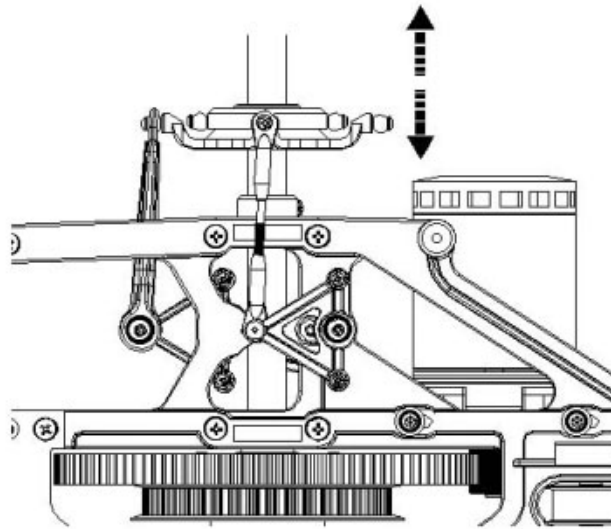

■ AILERON

Aileron is controlled by the 2 servos in front of the servo tray. When an aileron command is given, one servo will pull the swashplate downward and the other will push the swashplate upward so that the roll command is executed. They move contrary with same speed and travel distance but the third servo in back of the servo tray is remain still at this moment.

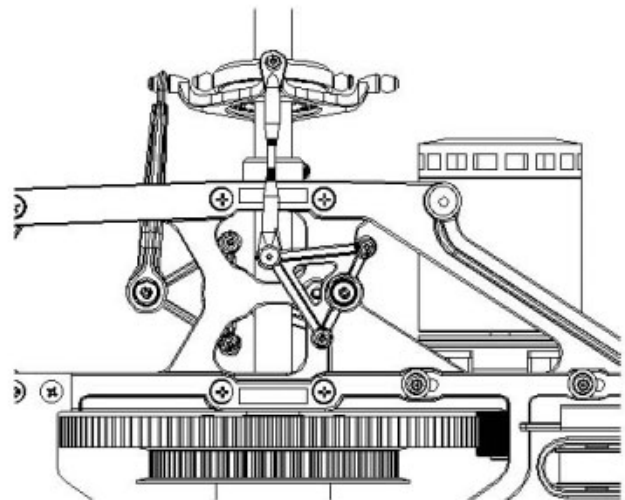
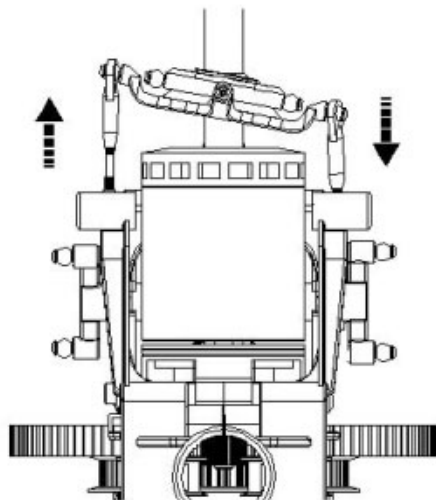

MOVEMENT OF 90°/140° E-CCPM SYSTEM

■ ELEVATOR

1. For 90° E-CCPM:

The elevator is only controlled by one servo. When an elevator command is given, the servo plugged into the elevator channel will pull/push the swashplate to tilt. The 2 remaining servos are supposed to stay still. As a result, only 1 servo is in charge of the elevator control while using 90° E-CCPM system.

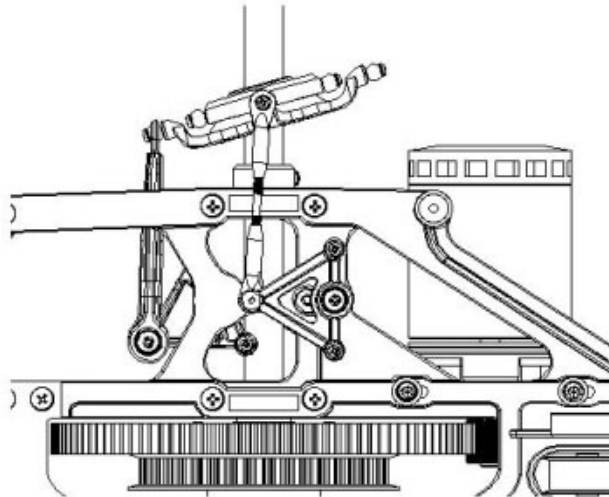

2. For 140° E-CCPM:

The elevator is controlled by all of the 3 servos with 140° E-CCPM setup. When an elevator command is given, the 2 servos in front of the servo tray move in the same direction and the third one move contrary. For example, when a down elevator command is given, the 2 front servos push the swashplate upward and the third one pull the swashplate downward so that the down elevator command is executed. The 3 servos pull/push the swashplate at the same time with same speed and travel distance to accomplish the given command. With 140° E-CCPM, it minimizes the interaction between collective and cyclic control that the precision can be better.

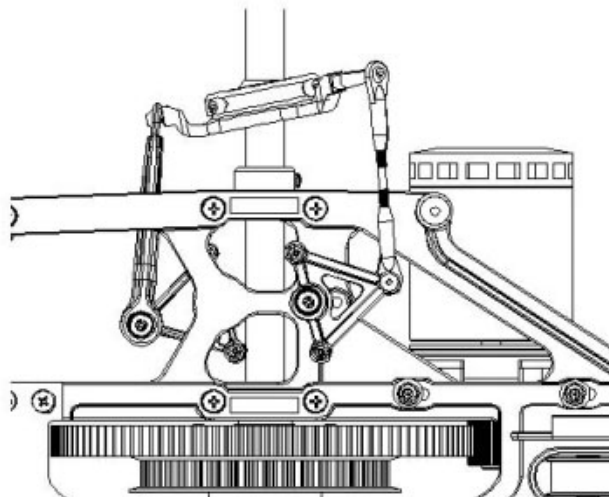

SERVO CONNECTING

E-CCPM system requires 3 channel for aileron, elevator and an AUX*for pitch*. But people may get confused because the 3 channels are not referred to any movement independently, they are operated together to carry out the rolling, flipping and collective controlling. As a result, the following connecting manner is recommended.

1. The rear servo located back of the tray MUST be plugged into the elevator channel.
2. Suppose the 1st servo in front of the tray is plugged into the aileron channel.
3. The 2nd servo is plugged into the AUX channel.

The following chart is the E-CCPM connecting for your reference. Please also consult your radio instruction manual.

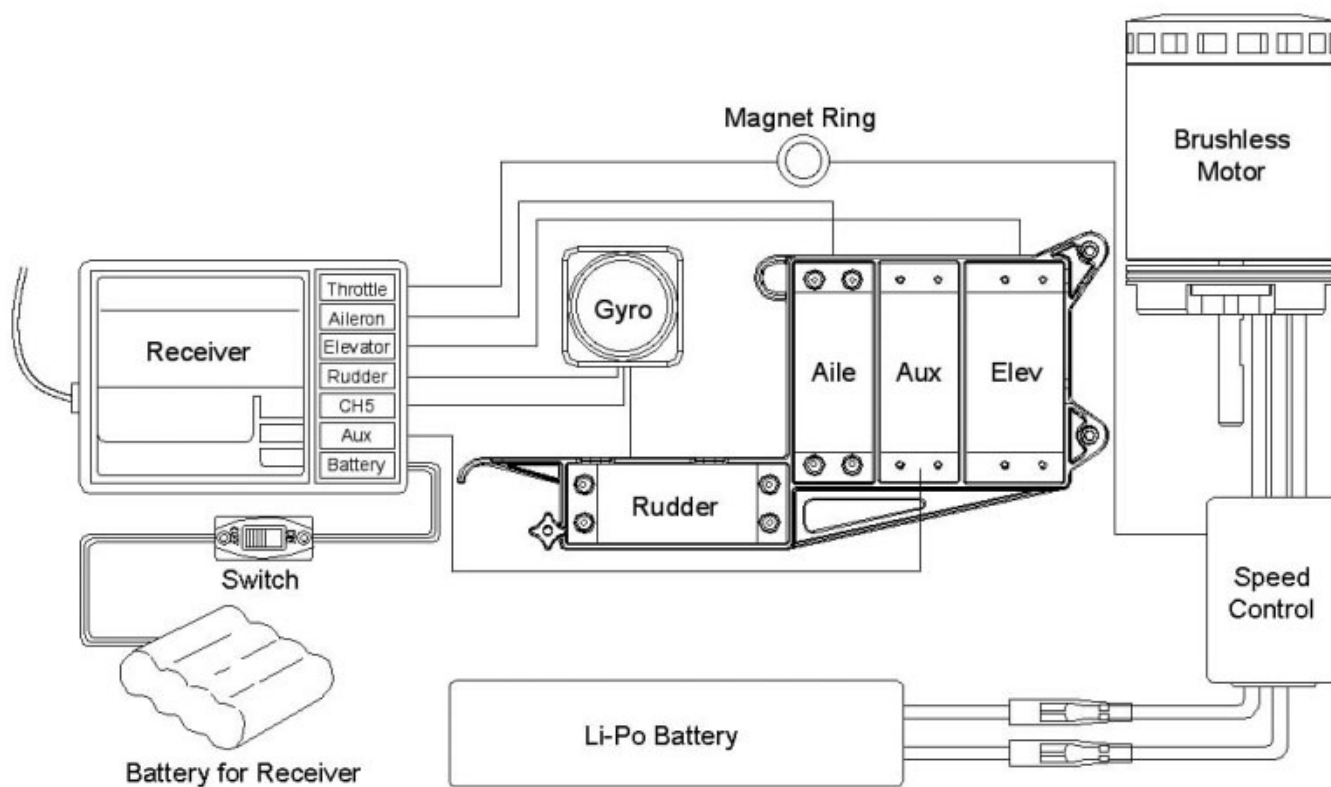

BASIC CONCEPT OF ADJUSTMENT

Because people may be confused with the operating manner of the E-CCPM system, we want to explain the basic concept of how to center and trim the servo while adjusting the full travel distance.

First of all, we have to make it clear about what do you want to adjust. Do you want to adjust the servo itself or the control surface? For example, if you want to adjust the servo which plugged into the aileron channel itself, only the servo will be adjusted. But if you want to adjust the aileron (rolling) surface, two servos which plugged into aileron and AUX channels will be adjusted. Making clear of this basic concept will simplify the process of adjustment. Furthermore, you have to realize the function of "Reverse", "Sub Trim", "Trim", "Travel Adjustment", "D/R & EXP" and "Swash Mixing" of the transmitter. There are different names for those functions between different brands of the radio, but their definitions are basically the same. The following table shows the functions which those items refer to:

Items	Adjust the Servo Itself	Adjust the Control Movement
Reverse	★	
Sub Trim	★	
Travel Adjustment	★	
Trim		★
D/R & EXP		★
Swash Mixing	± Aileron	★
	± Elevator	★
	± Pitch	★

Therefore, if you want to adjust servos themselves, please use the "Reverse", "Sub Trim", and "Travel Adjustment". If you want to adjust the control surface, please use the "Trim", "D/R & EXP" and "Swash Mixing". For example, it is necessary to do minor centering adjustments to achieve the desired servo arm position with the "Sub Trim" function. Under this circumstance, you have to adjust the servo itself, not the control surface.

CONCEPT OF BASIC SETTING AND ADJUSTMENT

Before starting, make sure the following preparation is done:

1. Set all trims, knobs, and switches to the neutral and zero position.
2. Reset the radio to its factory preset position.
3. Choose the 90° /140° E-CCPM swashplate control mode.

■ Reversing/Swash Mixing

The moving direction of servos has to be confirmed. You can attach the servo arms to the servos temporarily so that it makes it easier to see the servos moving direction. While giving a positive collective pitch, all of the 3 servos are supposed to be moving in the same direction to raise the swashplate. If the 3 servos are moving in the same direction but to descend the swashplate, you have to use the "swash mixing" function to make it raises. If any of the servos is moving contrary, you have to adjust the one by "reverse" function. Since the moving manner above is determined, the "reverse" function of Aile/Elev/AUX is done.

Next, you have to check the control surface. While giving a cyclic pitch control, the swashplate has to be tilted toward the correct direction. If not, you have to adjust it by "swash mixing" function. For example, if a down elevator command is given, the swashplate is supposed to be tilted forward. If the swashplate is tilted rearward, you have to change the +/- of the elevator control surface by "swash mixing" function. So as the aileron control surface.

To sum up, the "reverse" function is to adjust the servo itself, and the +/- of the "swash mixing" function is to adjust the control surface.

■ Servo Arms

After the moving direction of the servos is determined, please center the collective control stick. With the collective control stick is centered, install the servo arms of the 3 servos. They are supposed to be vertical. If the servo arms tilt with a small degree, use the "sub trim" function to adjust it independently. Thus the procedure of centering is complete.

CONCEPT OF BASIC SETTING AND ADJUSTMENT

■ Level the Swashplate

After centering the servos, setting the length of the control linkages and attaching them to the link balls, it is important to check the swashplate that it is level. Turn on the transmitter and the receiver, and center the collective pitch stick. Make sure all the trims and knobs are centered and the pitch curve should be 0% at low end and 100% at high end at present. The servo arms should be vertical. While the collective pitch stick is centered and the servo arms are vertical, the swashplate is supposed to be level. First, check the swashplate from the rear of the model to insure if it's level from left to right. If the swashplate is not level as compared to the frame of the model, adjust either the left or right servo control rods. Next, check the swashplate from a side of the model to insure if it's level from head to rear. If the swashplate is not level, it is suggested to adjust both the left and right rods at the same time.

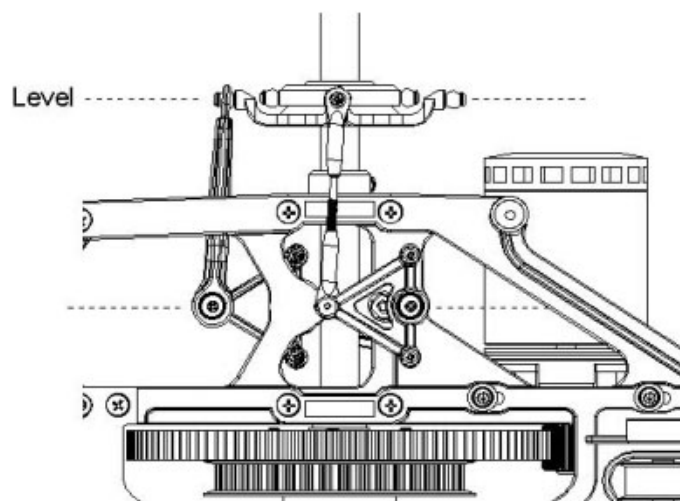
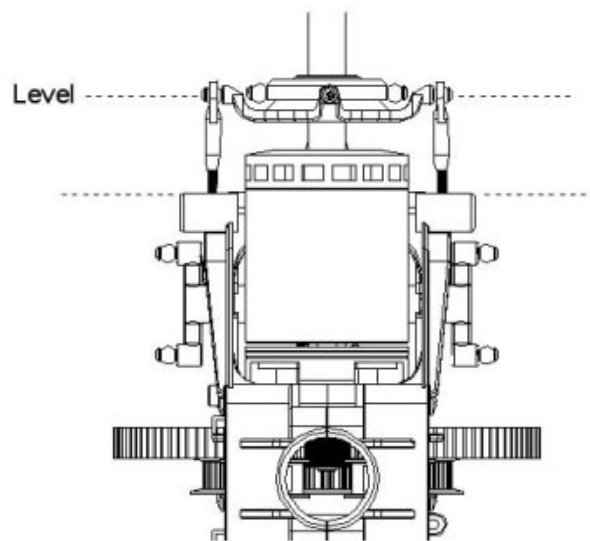

COLLECTIVE TO CYCLIC MIXING ADJUSTMENT

It always happens that the travel of each servo varies slightly. If so, the swashplate would be tilted when giving a full collective pitch command. These variations can be corrected by altering the travel value of each servo slightly by using the "Travel Adjustment" function.

■ Pitch to Aileron Mixing

Place the collective stick to the full positive pitch position. Check the swashplate from the rear of the model to insure if it's level from left to right. If the swashplate is not level as compared to the frame of the model, adjust either the servos by using the "Travel Adjustment" function.

For example, the swashplate has been tilted to the right side while giving full positive collective pitch. It indicates that the left servo's travel is greater than the right servo's travel. You can either decrease the travel of left servo or increase the travel of right servo. Check the swashplate again to insure that it's level.

It is necessary to repeat the procedure while giving full negative collective pitch. Check if the swashplate is level and adjust the servos as needed while the full negative collective pitch is given.

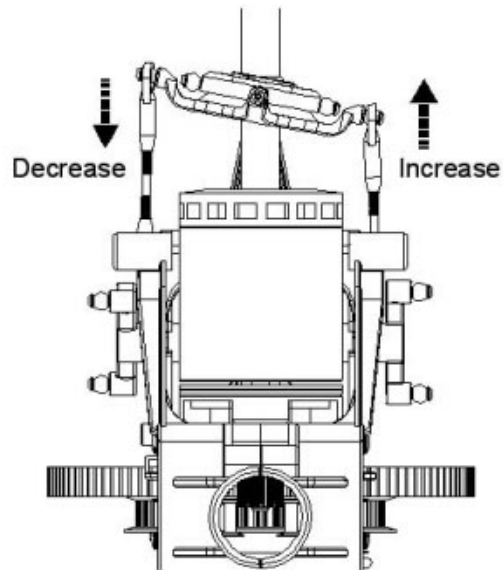

■ Pitch to Elevator Mixing

Through the previous step, we've got rid of the pitch to aileron mixing. It is as important to vanish the pitch to elevator mixing. Place the collective stick to the full positive pitch position. Check the swashplate from a side of the model to insure if it's level from head to rear. If the swashplate is not level, adjust the elevator servo by using the "Travel Adjustment" function.

For example, the swashplate has been tilted forward while giving full positive collective pitch. It indicates that the elevator servo's travel is less than the rest two's travel. Please increase the travel of elevator servo. Check the swashplate again to insure that it's level.

It is necessary to repeat the procedure while giving full negative collective pitch. Check if the swashplate is level and adjust the elevator servo as needed while the full negative collective pitch is given.

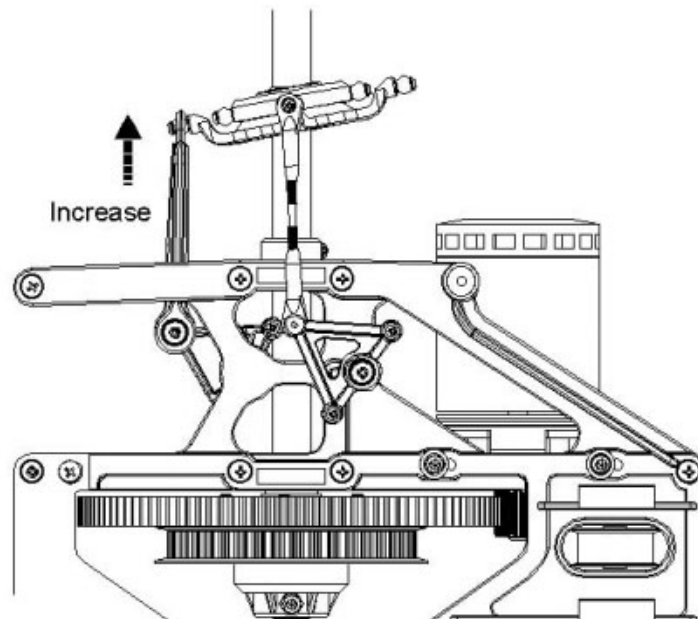

SETTING UP OF LINKAGE

The lengths of the linkage rods are recommended as the following:

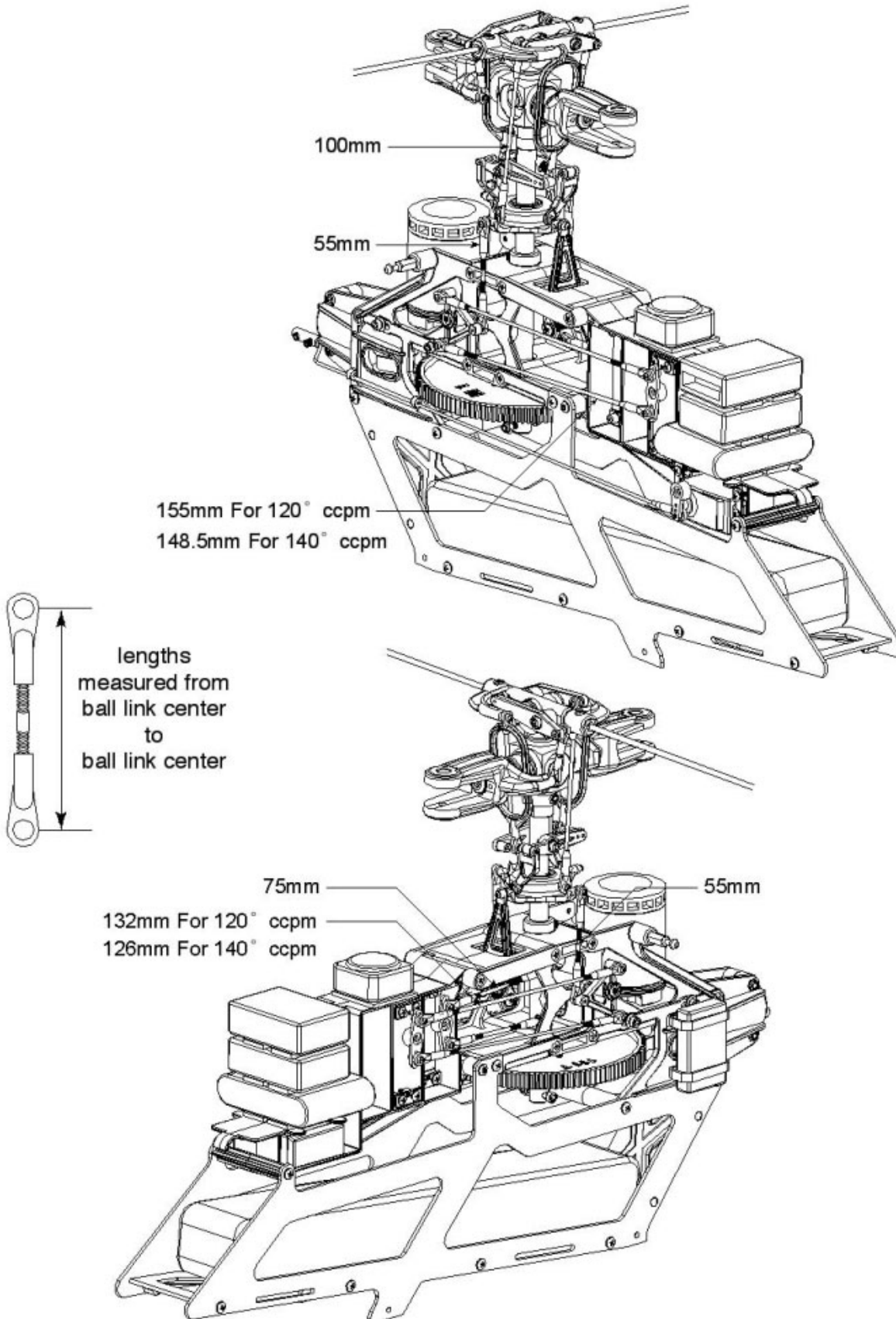

The pushrod length above is suitable for beginner and 3D flying. You can use those lengths as the starting setting, and adjust the lengths for your flying style. The lengths of the pushrods are measured from the center of the linkage ball to the center of another.

SETTING UP MAIN ROTOR BLADES PITCH ANGLE

Since you have been setting the lengths of the pushrod as mentioned, the linkage should be centered well as described below.

■ Centering

1. The elevator and aileron control levers should be as the drawing below while centering the collective pitch stick.
2. Parallel the flybar, the main blades should be at 0 degree and the swashplate should be level.

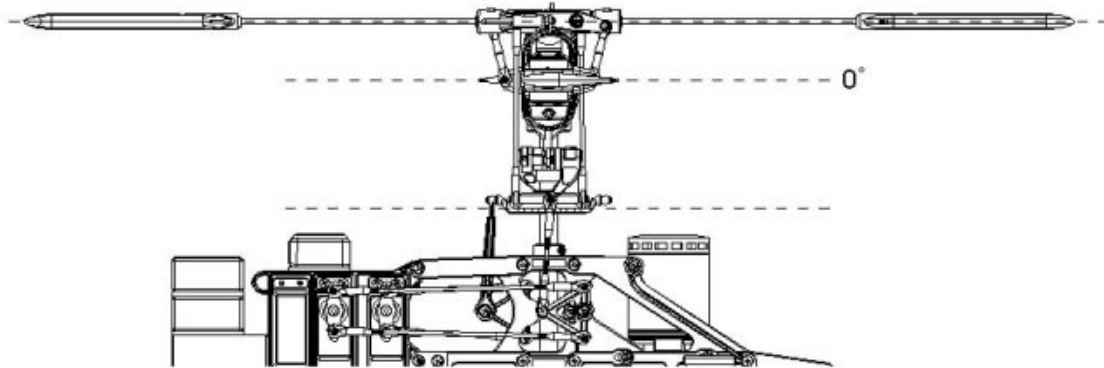

■ Maximizing

1. Place the collective stick at high end.
2. The main blades should be at 10 degree and the swashplate should be level.

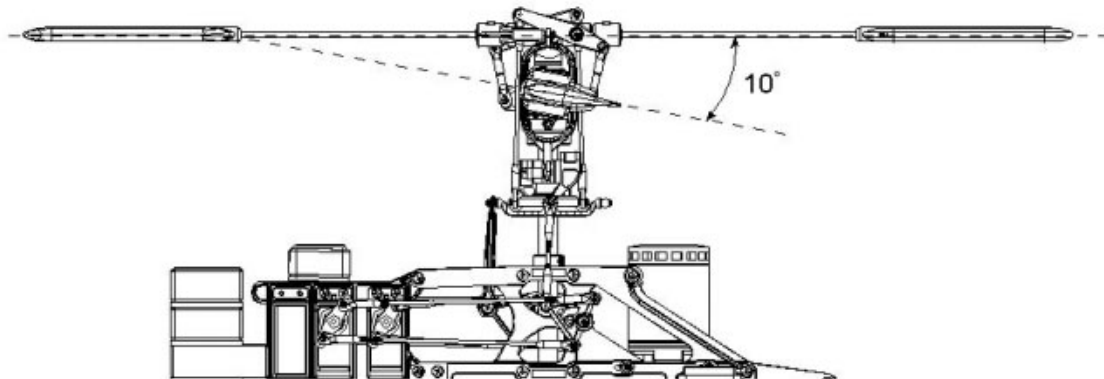

■ Minimizing

1. Place the collective stick at low end.
2. The main blades should be at 10 degree and the swashplate should be level.

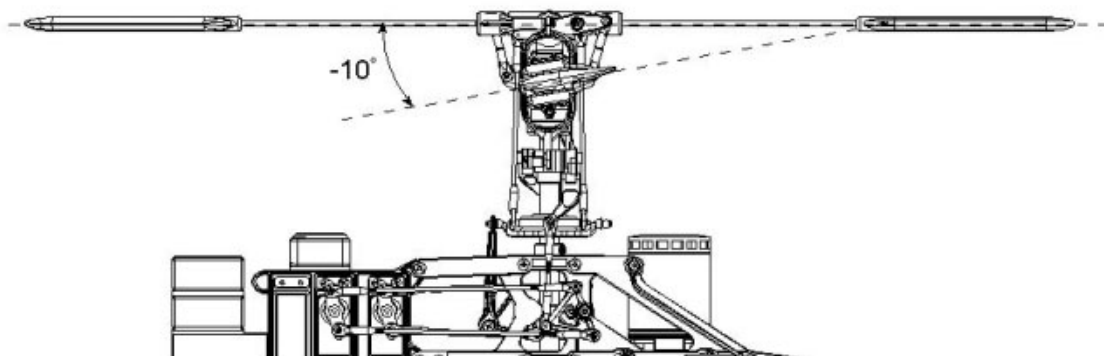

NOTE1 : The steps above defines the limits of the collective pitch setting.

NOTE2 : The setting of the maximum collective pitch depends on your personal flying skill and style. Too much collective pitch could overload the ESC, motor and the battery. And it will reduce the flying time also.

SETTING UP DATA FOR YOUR REFERENCE

The following is the setting up data of pitch curve and throttle curve for your reference only. Please ask experienced pilot to help you if you have never done this before.

■ Beginner

Throttle Curve

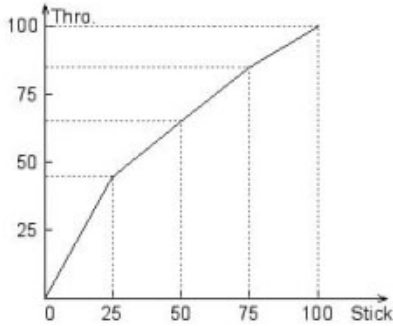

Pitch Curve

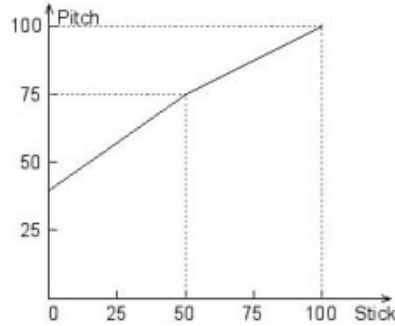

Throttle Curve

	0	25	50	75	100
Normal	0	45	65	85	100

Pitch Curve

	0	25	50	75	100
Normal	40	-	75	-	100

Pitch Angle

	0	25	50	75	100
Normal	-2°	-	+5°	-	+10°

■ F3C

Throttle Curve

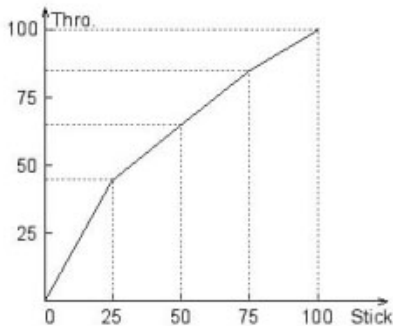

○ Normal

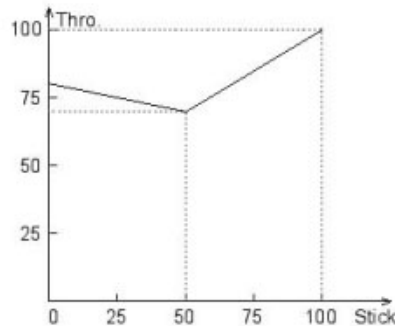

○ Idle-up 1

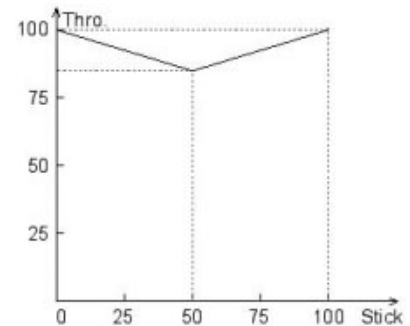

○ Idle-up 2

Pitch Curve

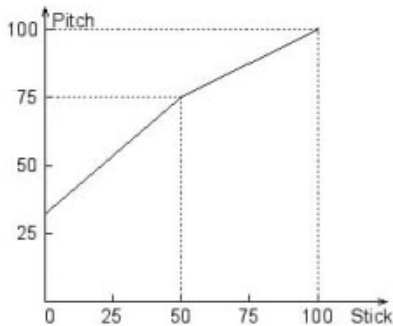

○ Normal

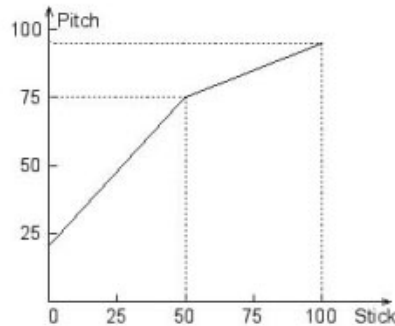

○ Idle-up 1

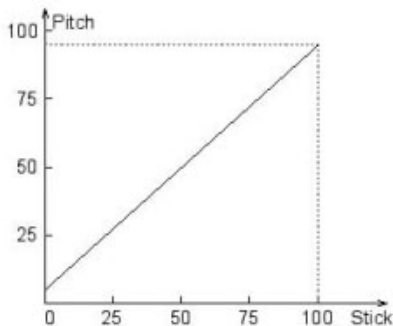

○ Idle-up 2

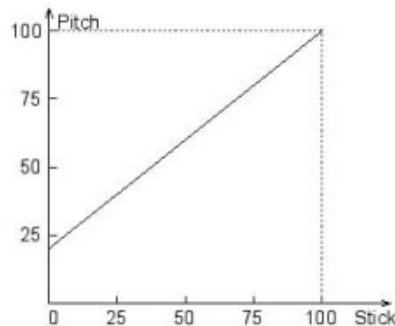

○ Hold

Throttle Curve

	0	25	50	75	100
Normal	0	45	65	85	100
Idle-up 1	80	-	70	-	100
Idle-up 2	100	-	85	-	100

Pitch Curve

	0	25	50	75	100
Normal	30	-	75	-	100
Idle-up 1	20	-	75	-	95
Idle-up 2	5	-	-	-	95
Hold	20	-	-	-	100

Pitch Angle

	0	25	50	75	100
Normal	-4°	-	+5°	-	+10°
Idle-up 1	-6°	-	+5°	-	+9°
Idle-up 2	-9°	-	-	-	+9°
Hold	-6°	-	-	-	+10°

SETTING UP DATA FOR YOUR REFERENCE

■ 3D

Throttle Curve

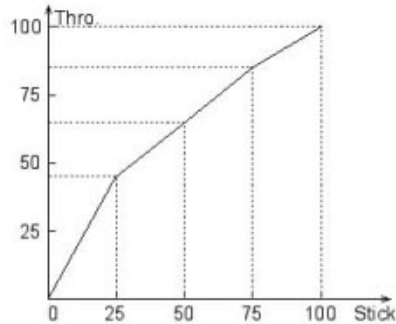

Ⓐ Normal

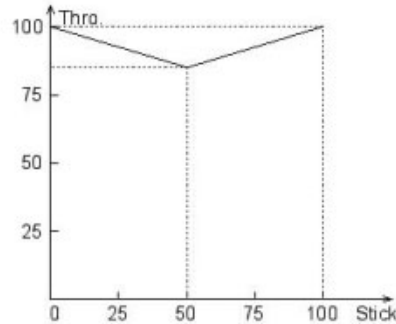

Ⓑ Idle-up 1

Throttle Curve

	0	25	50	75	100
Normal	0	45	65	85	100
Idle-up 1	100	-	85	-	100

Pitch Curve

	0	25	50	75	100
Normal	30	-	75	-	100
Idle-up 1	5	-	-	-	95
Hold	0	-	-	-	100

Pitch Curve

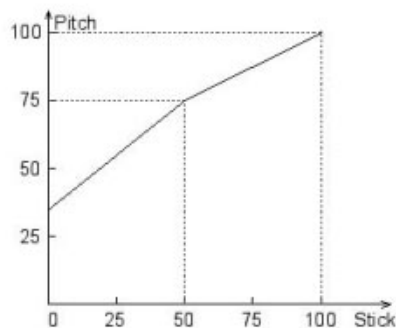

Ⓐ Normal

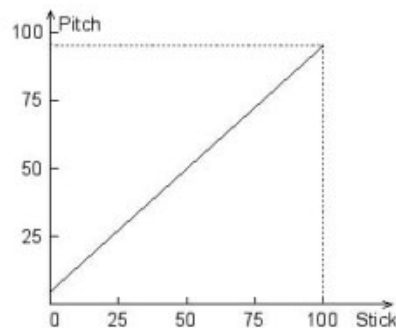

Ⓑ Idle-up 1

Pitch Angle

	0	25	50	75	100
Normal	-4°	-	+5°	-	+10°
Idle-up 1	-9°	-	-	-	+9°
Hold	-10°	-	-	-	+10°

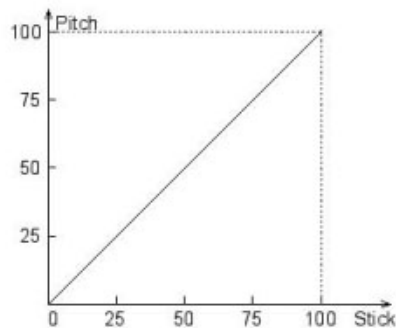

Ⓒ Hold

⚠ WARNING

1. Too much pitch will bring about too much current to the motor and the ESC.
2. Too much headspeed will lead to blades (grips) explosion.
3. It's very dangerous for setting the headspeed over the blades (grips) limit.

TAIL CONTROL AND GYRO SETUP

It is recommended to use a Heading Hold Gyro. With a Heading Hold Gyro, you may not use the trim and the revolution mixing function of tail control.

First, choose the length of the tail servo arm referring to the manual of the Gyro. You may try 13.5mm as the starting setting. Then mount the servo arm for the moment and check the movement of the tail servo:

1. While giving the right rudder control, the servo arm should move forward.
2. Rotate the helicopter with your hand counterclockwise, the servo arm should move forward.

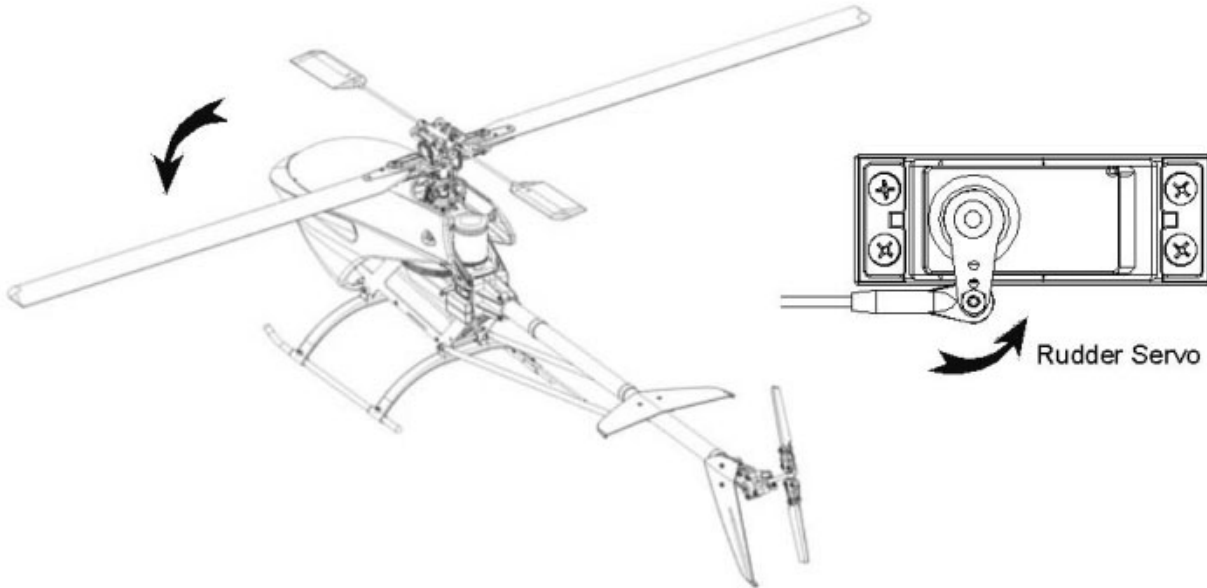

After making sure of moving direction of tail servo, you have to mount the servo arm in the correct position. Please reset the receiver power and do not move the helicopter. While the tail control stick and trim are centered, mount the servo arm vertically. If you cannot mount the servo arm vertically, please use the "sub trim" function to position the arm. Restart the power of receiver after using "sub trim" function so that the Gyro can reset the neutral point.

Next, two points may be your concern:

1. The traveling limit of the tail servo may not go beyond the mechanical movement.
2. The tail servo horn should be vertical while the tail rotor are at 0 pitch or with a little offset to the right. (Referring to the photo below)

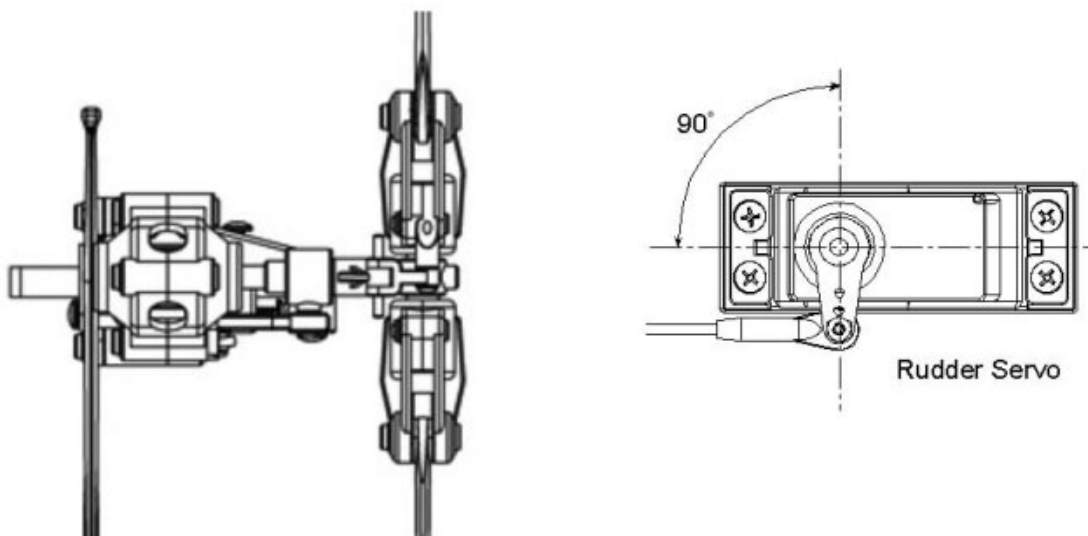

Note1: To find the traveling limit, you have to adjust the Gyro referring to its manual.

Note2: To adjust the pirouetting speed of the helicopter, please use the "Travel Adjustment" or the "D/R & EXP" function.

TROUBLE SHOOTING

Helicopters

Q: What would you check when the helicopter shakes during flying?

- A:
- Are the main blades out of track?
 - Are the paddles out of track?
 - Are the main blades well balanced?
 - Are the paddles well mounted at the same distance from the rotor shaft?
 - Is the spindle or the flybar bent?
 - Is the main shaft bent?
 - Is the main rotor hub damaged?
 - Is the motor well installed and is the shaft of the motor bent?
 - Is the tail rotor shaft bent?
 - Is the tail rotor hub damaged?
 - Do all the ball bearings work well?

Q: What would you do if there comes out a lot of noise from the helicopter during flying?

- A:
- Please check the gear mesh between the main gear and the motor pinion. If there is too much gear mesh, it would generate a lot of gear noise during flying.
 - If the tail drive belt is too loose, it will bring about some noise and may cause the failure of tail control.
 - Check linkage and control system of main rotor and tail rotor to make sure every linkage is working correctly and not colliding with something else.
 - Check if motor is running out of balance.

Motor, Battery and Speed Controller

Q: How to choose the motor and the pinion?

A: It depends on the battery and the motor. The following is the formula of how to calculate the wanted head speed.

$$\text{Motor RPM} = \text{Motor KV} \times \text{Volt}(3.7\text{V}) \times \text{Series} \times \text{constant} (0.9)$$

$$\text{Head Speed} = \text{Motor RPM} / \text{Gear Ratio}$$

$$\text{Gear Ratio} = 111\text{T} / \text{Motor Pinion}$$

Example: 6S setting

We choose TT OBL 43/11-30H brushless motor, the motor rpm should be

$$1050\text{KV} \times 3.7\text{V} \times 6\text{S} \times 0.9 = 20979 \text{ rpm}$$

And we expect to have the head speed of 1900rpm

$$20979 / \text{Gear Ratio} = 1900$$

$$\text{Gear Ratio} = 11.04$$

So the pinion would be

$$111\text{T} / 11.04 = 10\text{T}$$

Example: 10S setting

We choose TT OBL 49/08-50H brushless motor, the motor rpm should be

$$770\text{KV} \times 3.7\text{V} \times 10\text{S} \times 0.9 = 25641 \text{ rpm}$$

And we expect to have the head speed of 2100rpm

$$25641 / \text{Gear Ratio} = 2100$$

$$\text{Gear Ratio} = 12.21$$

So the pinion would be

$$111\text{T} / 12.21 = 9\text{T}$$

Q: Which speed controller is recommended?

A: For 6S setting, the ACE BLC-75 No.8043 is recommended. For the 10S setting, the ACE BLC-65 No.8042 is recommended.

PARTS LIST SECTION

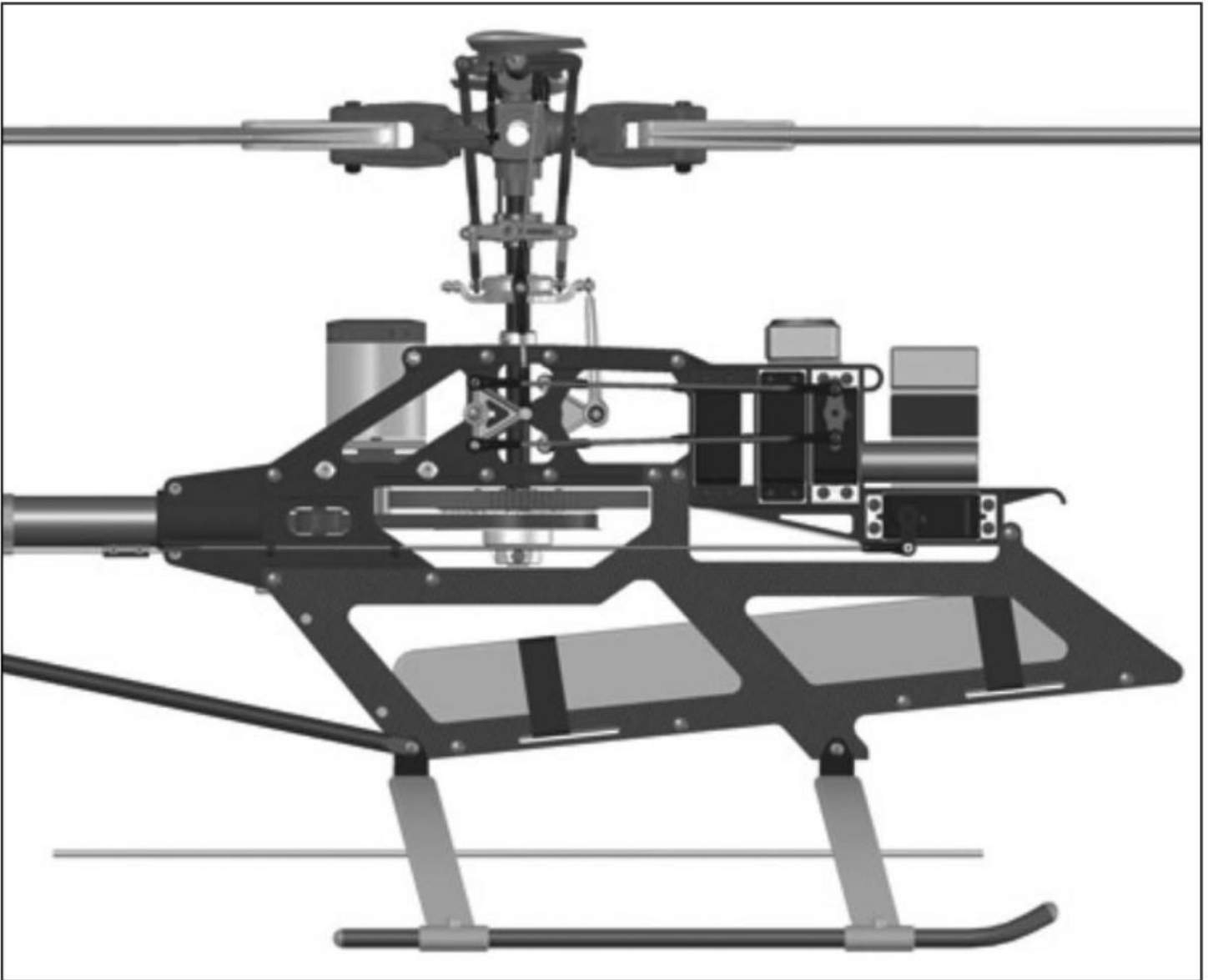



AK0060-T TAIL BOOM, R30/E550



AK0089 TAIL DRIVE BELT 630XL, R30/E550

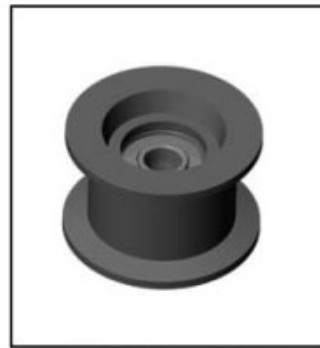

AV0052 TAIL IDEL PULLEY ASSY.



PV0002 FLYBAR CONTROL ARM



PV0004 MIXING LEVER



PV0005 FLYBAR CONTROL ROD



PV0016 T. PITCH CONT. LEVER



PV0018 MAIN SHAFT LOCK RING



PV0019 ONE WAY CLUTCH



PV0020 ONE WAY CLUTCH SHAFT



PV0021 GUIDE PULLEY ASSY.



PV0027 TAIL CASE



PV0029 TAIL PULLEY



PV0030 TAIL ROTOR SHAFT

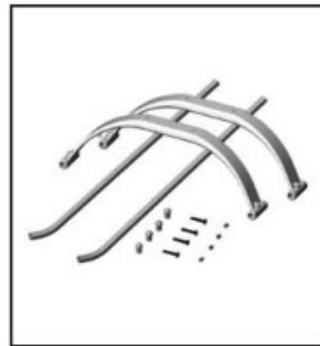

PV0035 LANDING SKID
PV0035-T LANDING SKID

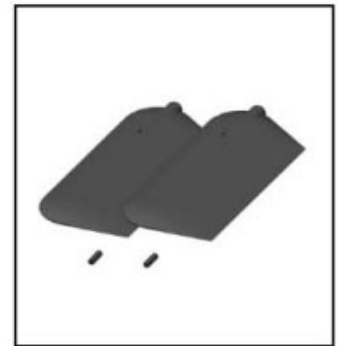

PV0036 FLYBAR PADDLE



PV0037 TAIL ROTOR BLADE

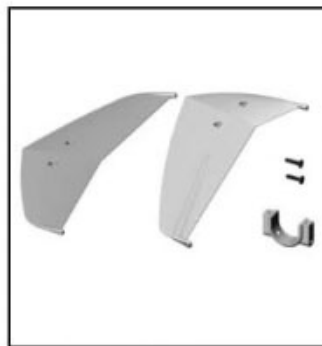

PV0038 TAIL FIN



PV0040 DOUBLE LINK



PV0041 BALL LINK



PV0048 BALL BEARING,
d4XD8XW3

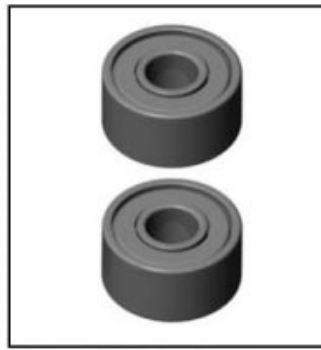

PV0049 BALL BEARING,
d4XD8XW4

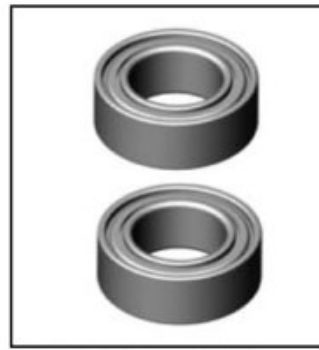

PV0051 BALL BEARING,
d4XD7XW2.5



PV0052 BALL BEARING,
d6XD10XW3



PV0053 ROTOR BOLT

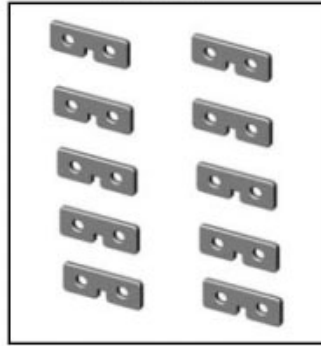

PV0054 SERVO MOUNTING
PLATE

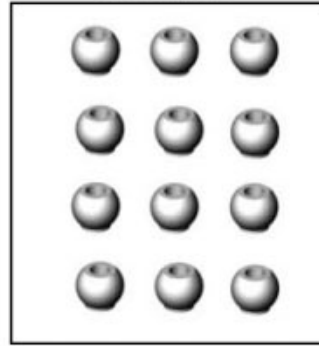

PV0058 LINKAGE BALL

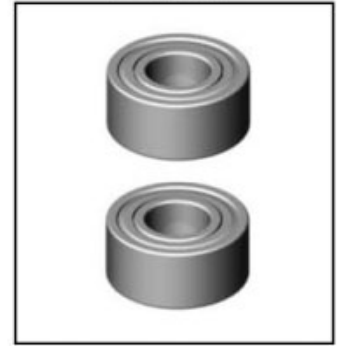

PV0059 BALL BEARING,
d5XD11XW5

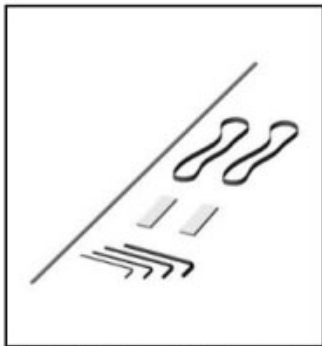

PV0060 INSTALLATION TOOLS

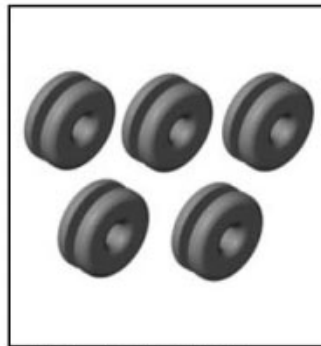

PV0062 BODY MOUNT
RUBBER



PV0092 METAL SWASH PLATE
ASSY

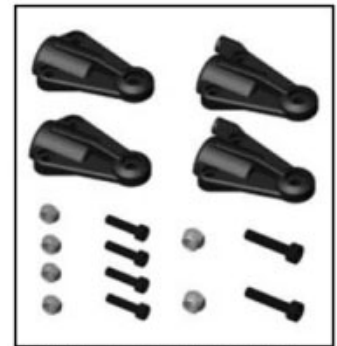

PV0148 TAIL ROTOR GRIP



PV0151 TAIL ROTOR HUB

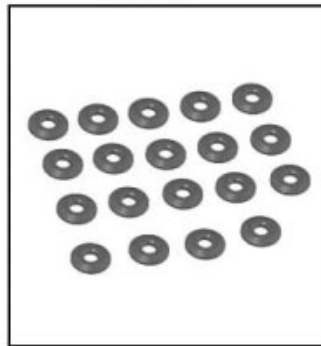

PV0209 WASHER, d4xD11xT1.7

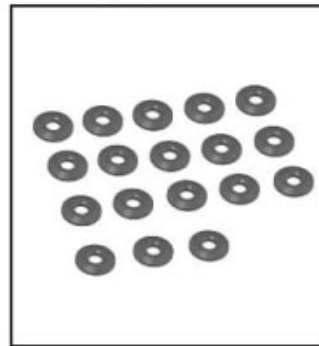

PV0210 WASHER, d3xD8xT1.4



PV0239 BODY CLIP



PV0244 BALL BEARING,
d10xD19xW5

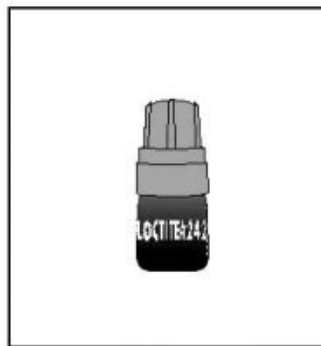

PV0267 LOCTITE #242



PV0268 LOCTITE #262



PV0270 THRUST BEARING
GREASE



PV0279 TAIL ROD GUIDE



PV0328-T TAIL SUPPORT, R30/E550
PV0329-T TAIL SUPPORT, R50T/E620



PV0338 METAL M. ROTOR HUB



PV0353 MAIN ROTOR GRIP



PV0354 MAIN ROTOR HUB



PV0355 SPINDLE

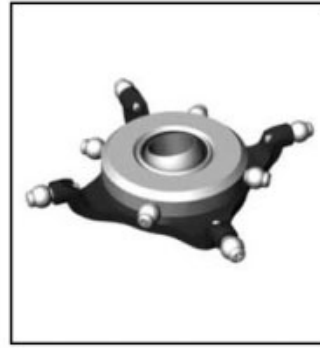

PV0357 SWASHPLATE

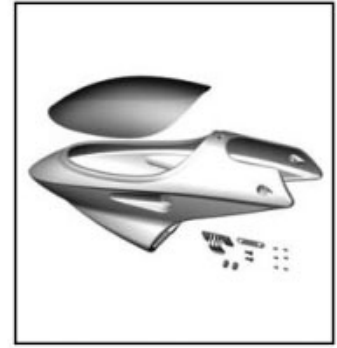

PV0364 CANOPY

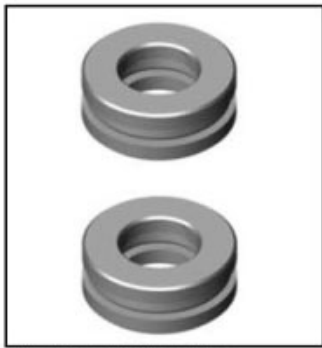

PV0365 THRUST BRG

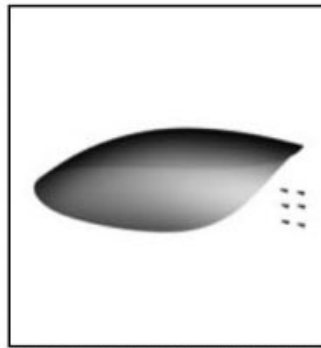

PV0369 WIND SHIELD ONLY

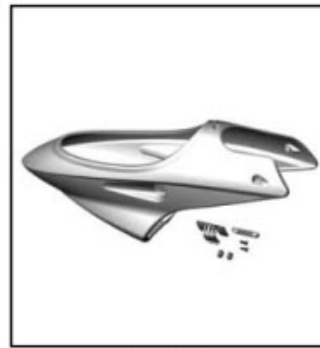

PV0370 CANOPY ONLY



PV0372 THRUST COLLAR

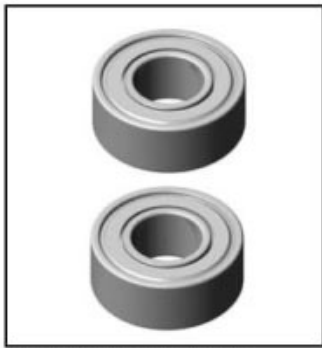

PV0374 BALL BEARING,
d6xD13xW5



PV0375 BODY RETAINING SET



PV0379 AUTO-R TAIL PULLY



PV0381 FLAP DAMPER



PV0382 FLAP DAMPER

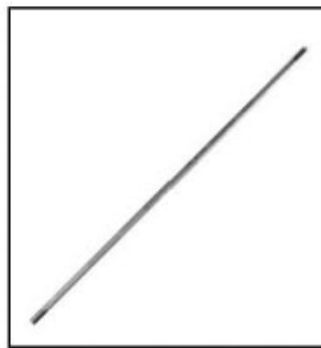

PV0450 SUS FLYBAR ROD



PV0451 HARDENED MAIN
SHAFT

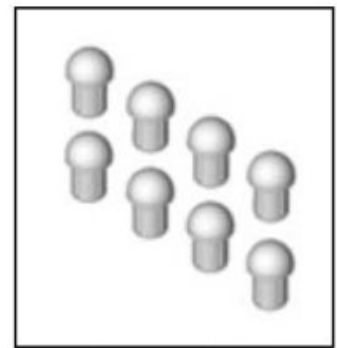

PV0454 SKID PIPE CAP



PV0486 FLYBAR SEESAW



PV0503 WASHOUT SET



PV0504 TAIL PITCH SLIDER



PV0517 ONEWAY GREASE

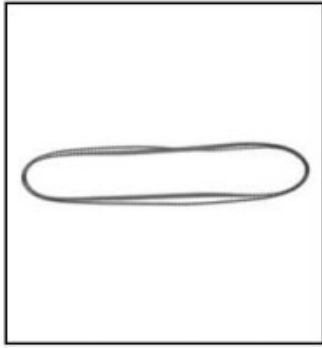

PV0520 TAIL DRIVE BELT
686XL, R50T/E620



PV0521 TAIL BOOM, R50T/E620

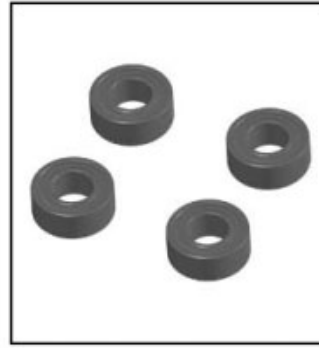

PV0526 BALL BEARING,
d5xD10xW4



PV0542 TAIL PITCH C FORK



PV0543 SKID BRACE

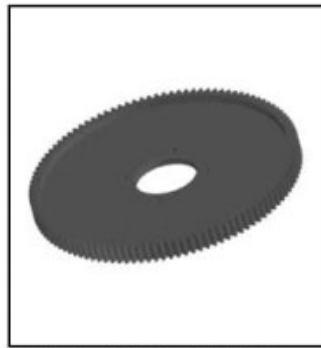

PV0544 111T MAIN GEAR,
E550/E620

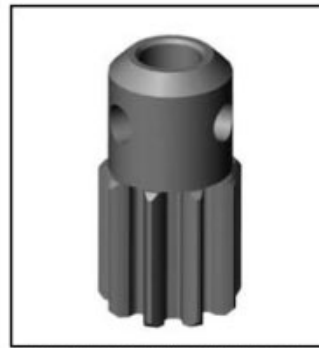

PV0545 MOTOR PINION, 9T

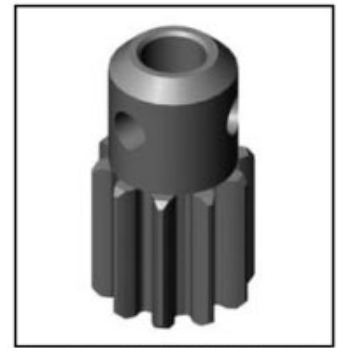

PV0546 MOTOR PINION, 10T

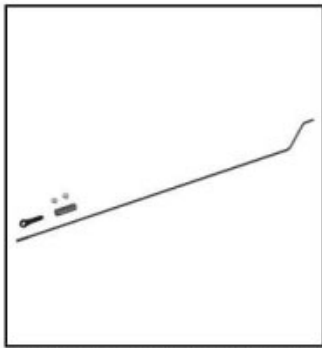

PV0550 TAIL CONTROL ROD, E550
PV0551 TAIL CONTROL ROD, E620



PV0552 LINKAGE ROD,
E550/E620

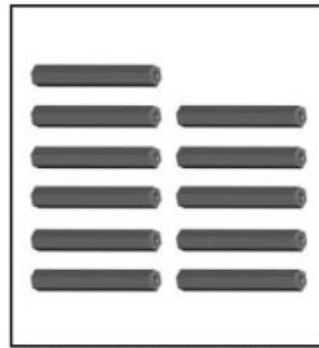

PV0553 FRAME SPACER,
E550/E620



PV0554 ELEV. ARM LEVER,
E550/E620



PV0555 ELEV. A ARM,
E550/E620



PV0556 AILERON LEVER,
E550/E620

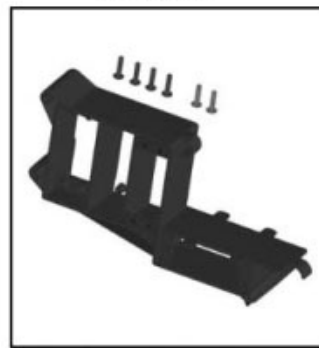

PV0557 SERVO TRAY,
E550/E620



PV0558 MAIN FRAME,
E550/E620



PV0559 AL LOWER FRAME, E550



PV0560 CFRP LOWER FRAME, E620

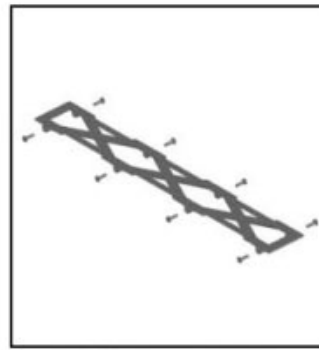

PV0561 BOTTOM FRAME, E550/E620



PV0562 BATT RR BRACKET, E550/E620

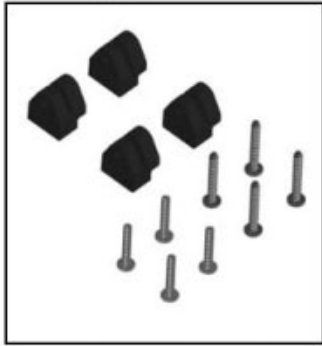

PV0563 SKID ADAOPTR, E550/E620



PV0564 DECAL, E550



PV0565 DECAL, E620 SE



PV0572 VELCRO



PV0574 MOTOR MOUNT, E550/E620

	HMF2-6N M2X6 HMF2-8N M2X8
	HMJ2-10N M2X10 HMJ2-14N M2X14 HMJ2-6B M2X6 HMJ3-22B M3X22
	HSE2-10B M2X10 HSE2612N M2.6X12 HSE3-12B M3X12 HSE3-18B M3X18
	HSE3-5B M3X5

PV0088 Screw Bag (6pcs each)

	HMC3-10B M3X10 HMC3-12B M3X12 HMC3-14B M3X14 HMC3-20B M3X20 HMC3-25B M3X0.5L25 HMC3-32B M3X0.5XL32 HMC3-8B M3X8 BK0616 M3x20
	HME3-10B M3X10 HME3-18B M3X18 HME3-5B M4X5

PV0089 Screw Bag (6pcs each)

Parts No.	Description	Item No.	Description	Quantity	Ref. Step
AK0060-T	Tail Boom, E550	BK0060-T	Tail Boom, E550	1	16
AK0089	Tail Drive Belt, 630XL	BK0089	Tail Drive Belt, 630XL	1	16
AV0052	Tail Idel Pulley	BV0052	Tail Drive Pulley	1	16
PV0002	Flybar Control Arm	BK0002	Flybar Control Arm	2	12
		BK0005	Flybar Arm Bushing	2	12
		BK0075	Linkage Ball	2	12
		HME4-5B	Set Screw, M4x5	2	12
		HMJ2-10N	Self-tapping Screw, M2x10	2	12
PV0004	Mixing Lever	BK0006	Mixing Lever	2	12
		BK0075	Linkage Ball	4	12
		BK0076	Collar (d4xD4x10)	2	12
		BK0088	Flat Washer	2	12
		HMC3-14B	Socket Screw, M3x14	2	12
		HMJ2-10N	Self-tapping Screw, M2x10	4	12
PV0005	Flybar Control Rod	BK0007	Flybar Control Rod	2	11
PV0016	T. Pitch Cont. Lever, R30	BK0024	Tail Pitch Control Lever	1	15
		BK0075	Linkage Ball	1	15
		BK0076	Collar(d4xD4x10)	1	15
		BK0088	Flat Washer	1	15
		HMJ2-8N	Self-tapping Screw, M2x8	1	15
		HSE3-18B	Self-tapping Screw, M3x18	1	15
PV0018	Main Shaft Lock Ring	BK0030	Main Shaft Lock Ring	1	9
		HME4-5B	Set Screw, M4x5	2	9
PV0019	One Way Clutch	BV0033	One Way Clutch Housing Set	1	8
		HMC3-12B	Socket Screw, M3x12	4	8
PV0020	One Way Clutch Shaft	BK0034	One Way Clutch Shaft	1	8
		HMC3-20B	Socket Screw, M3x20	1	8
		HMM3Z	Lock Nut, M3	1	8
		HMJ14	Retaining Ring, Ø14	2	8
PV0021	Guide Pulley Assy.	BV0035	Guide Pulley	1	5
		BK0036	Pulley Collar	2	5
		BK0081	Pin, D13x18	1	5
PV0027	Tail Case	BK0046	Tail Unit Housing (L)	1	15, 16
		BK0047	Tail Unit Housing (R)	1	15, 16
		HMC3-20B	Socket Screw, M3x20	4	15, 16
		HMC3-25B	Socket Screw, M3x25	2	15, 16
		HMM3Z	Lock Nut, M3	6	15, 16
PV0029	Tail Pulley Set	BK0050	Tail Pulley Set	1	15
		BK0051	Tail Pulley Flange	1	15
		BK0414	Pin, D2x12	1	15
		HME3-4B	Set Screw, M3x4	1	15
PV0030	Tail Rotor Shaft	BK0053	Tail Rotor Shaft	1	14
		BK0414	Pin, D2x12	1	14
		HME3-4B	Set Screw, M3x4	1	14
PV0035	Landing Skid Set	BK0064	Skid	2	7
		BK0065	Skid Cap	4	7
		BK0066	Skid Brace	2	7
		HMJ3-18B	Self-tapping Screw, M3x18	4	7
		HME4-5B	Set Screw, M4x5	4	7
PV0035-T	Landing Skid Set	BK0064T	Skid	2	7
		BK0065	Skid Cap	4	7
		BK0066	Skid Brace	2	7
		HMJ3-18B	Self-tapping Screw, M3x18	4	7

Parts No.	Description	Item No.	Description	Quantity	Ref. Step
		HME4-5B	Set Screw, M4x5	4	7
PV0036	Flybar Paddle	BK0067	Flybar Paddle	2	12
		HME3-10B	Set Screw, M3x10	2	12
PV0037	Tail Rotor Blade	BK0068	Tail Rotor Blade	2	17
PV0038	Tail Fin	BK0069	Stabilizer Fin	1	16
		BK0070	Stabilizer Fin Bracket	1	16
		BK0071	Vertical Fin	1	16
		HSE3-12B	Self-tapping Screw, M3x12	2	16
PV0040	Double Link	BV0085	Double Link	2	12
PV0041	Ball Link	BK0086	Ball Link	12	-
PV0048	Ball Bearing	HMV840ZZY	Bearing, d4xD8xW3	2	12
PV0049	Ball Bearing	HMV830ZZ	Bearing, d3xD8xW4	2	12
PV0051	Ball Bearing	HMV740ZZY	Bearing, d4xD7xW2.5	4	12, 15
PV0052	Ball Bearing	HMV1060	Bearing, d6xD10xW3	2	14
PV0053	Rotor Bolt	HMC4-27B	Socket Screw, M4x27	2	21
PV0054	Servo Mounting Plate	BK0104	Servo Mounting Plate	10	18, 19
PV0058	Linkage Ball	BK0075	Linkage Ball	12	-
PV0059	Ball Bearing	HMV1150X	Bearing, d5xD11xW5	2	15
PV0060	Installation Set	BE1052	Antenna Tube	1	-
		BK0106	Double Side Tape	2	-
		BK0109	Rubber Band	2	-
		HNI15	Hex Wrench, 1.5mm	1	-
		HNI2	Hex Wrench, 2.0mm	1	-
		HNI25	Hex Wrench, 2.5mm	1	-
		HNI3	Hex Wrench, 3.0mm	1	-
		HNJ-1	Tie Band	3	-
PV0062	Body Mount Rubbergromet	BK0102	Body Mount Rubber	5	20
PV0092	Metal Swash Plate	BV0092	Metal Swash Plate	1	9
PV0148	Tail Rotor Grip	BK0302-1	Tail Pitch Housing (A)	2	14
		BK0303-1	Tail Pitch Housing (B)	2	14
		HMC2610B	Socket Screw, M2.6x10	4	14
		HMM26B	Lock Nut, M2.6	4	14
		HMC3-14B	Socket Screw, M3x14	2	14
		HMM3Z	Lock Nut, M3	2	14
PV0151	Tail Rotor Hub	BK0307	Tail Rotor Hub	1	14
		HME3-18B	Set Screw, M3x18	2	14
		HMM3B	Lock Nut, M3	2	14
PV0209	Washer	BK0435	Washer, d4xD11x1.7	4	11
PV0210	Washer	BK0087	Washer, d3xD8x1.4	16	10
PV0239	Body Clip	BK0098	Body Clip A	1	20
		BK0099	Body Clip B	1	20
		HSE3-12B	Self-tapping Screw, M3x12	2	20
PV0244	Ball Bearing	HMV6800ZZY	Ball Bearing, d10xD19xW5	2	5
PV0267	Loctite #242			1	-
PV0268	Loctite #262			1	-
PV0270	Thrust Bearing Grease			1	-
PV0279	Tail Rod Guide	BK0091	Rod Guide	3	16
PV0328-T	Tail Support	BK0447	Tail Support Rod End	4	16
		BK0540-T	Tail Support Rod, E550	2	16
		HMJ2-8N	Self-tapping Screw, M2x8	4	16
PV0329-T	Tail Support, R50T	BK0447	Tail Support Rod End	4	16
		BK0524	Tail Support Rod	2	16
		HMJ2-8N	Self-tapping Screw, M2x8	4	16

Parts No.	Description	Item No.	Description	Quantity	Ref. Step
PV0338	Metal M. Rotor Hub	BV0554	Metal M. Rotor Hub	1	11
		BK0585	Flap Damper (80°)	2	11
PV0353	Main Rotor Grip	BK0075	Linkage Ball	2	11
		BK0596	Main Rotor Pitch Housing	2	11
		HMJ2-10N	Self-tapping Screw, M2x10	2	11
PV0354	Main Rotor Hub	BK0587	Main Rotor Pin	1	11
		BK0616	Socket Screw, M3x20	1	11
		BK0595	Main Rotor Hub	1	11
		HMM3Z	HMM3Z	1	11
PV0355	Spindle, R30V2	BK0581	Flap Collar	2	11
		BK0583	Feathering Shaft	1	11
		BK0435	Washer, d4xD11x1.7	2	11
		HMC4-8B	Socket Screw, M4x8	2	11
PV0357	Swashplate	BV0601	Swashplate	1	9
PV0364	Body	BK0098	Body Clip A	1	20
		BK0099	Body Clip B	1	20
		BK0102	Rubber Grommet	2	20
		BK0611	Body	1	20
		BK0612	Canopy	1	20
		HSE3-12B	Self-tapping Screw, M3x12	2	20
PV0365	Thrust Bearing	HMX0612	Thrust Bearing	2	11
PV0369	Wind Shield Only	BK0612	Canopy	1	20
		HMJ2-6B	Self-tapping Screw, M2x6	6	20
PV0370	Body Only	BK0098	Body Clip A	1	20
		BK0099	Body Clip B	1	20
		BK0102	Rubber Grommet	2	20
		BK0611	Body	1	20
		HSE3-12B	Self-tapping Screw, M3x12	2	20
PV0372	Thrust Collar	BK0584	Thrust Collar	2	11
PV0374	Ball Bearing	HMV1360Z	Bearing, d6xD13xW5	2	11
PV0375	Body Retaining Set	BK0626	Body Mount Nut	2	13
		HME3-18B	Set Screw, M3x18	2	13
PV0379	Auto Rotation Pulley	BK0610	Auto Rotation Pulley	1	8
		HMC3-8B	Socket Screw, M3x8	4	8
PV0381	70° Flap Damper	BK0586	70° Flap Damper	2	11
PV0382	80° Flap Damper	BK0585	80° Flap Damper	2	11
PV0450	Sus Flybar Rod	BK0631	Sus Flybar	1	12
PV0451	Hardened Main Shaft	BK0702	Harden Main Shaft	1	9
PV0454	Skid Pipe Cap	BK0065	Skid Pipe Cap	8	7
PV0486	Flybar Seesaw	BK0004	Seesaw	1	12
		HMV830ZZ	Bearing, d3xD8xW4	2	12
PV0503	Washout Set	BK0014	Washout Base	1	8
		BK0015	Flybar Control Lever	1	8
		BK0016	Washout Linkage	2	8
		BK0075	Linkage Ball	2	8
		BK0077	Collar (d3xD4x6)	2	8
		BK0171	Pin	2	8
		HMC3-10B	Socket Screw, M3x10	2	8
		HMJ2-10N	Self-tapping Screw, M2x10	2	8
		HMS15	E Ring	2	8
PV0504	Tail Pitch Slider	BK0025	Tail Pitch Control Fork	1	14
		BK0026	Tail Pitch Control Linkage	2	14
		BK0027	Tail Pitch Control Slider	1	14

Parts No.	Description	Item No.	Description	Quantity	Ref. Step
		BK0028	Tail Pitch Control Slider Bushing	1	14
		BK0075	Linkage Ball	1	14
		BK0082	Collar (d2xD3x4)	2	14
		BK0546	Pin (2mm)	2	14
		HMF2-8N	Screw, M2x8	1	14
		HSE2-10B	Self-tapping Screw, M2x10	2	14
		HMS15	E Ring	4	14
PV0517	Oneway Bearing Grease	BV0857	Oneway Bearing Grease	1	8
PV0520	Tail Drive Belt, 686XL	BK0858	Belt, 686XL	1	16
PV0521	Aluminum Tail Boom	BK0859	Tail Boom	1	16
PV0526	Ball Bearing	HMV1050ZZ	Bearing, d5xD10xVW4	4	14
PV0542	Tail Pitch C.Fork,R30/50	BK0025	Tail Pitch Control Fork	1	14
		BK0026	Tail Pitch Control Linkage	2	14
PV0543	Skid Brace	BK0066	Skid Brace	2	7
PV0544	111T Main Gear	BK1112	111T Main Gear	1	8
PV0545	Motor Pinion, 9T	BK1124	Motor Pinion, 9T	1	10
PV0546	Motor Pinion, 10T	BK1117	Motor Pinion, 10T	1	10
PV0550	Tail Control Rod, E550	BK1123	Sus Push Rod A	1	16, 17
		BK1133	Sus Push Rod B	1	16, 17
		BK0086	Ball Link	1	16, 17
		BK0105	Tail Control Rod Joint	1	16, 17
		HME4-5B	Set Screw, M4x5	2	16, 17
PV0551	Tail Control Rod, E620 SE	BK1123	Sus Push Rod A	1	16, 17
		BK0861	Sus Push Rod B	1	16, 17
		BK0086	Ball Link	1	16, 17
		BK0105	Tail Control Rod Joint	1	16, 17
		HME4-5B	Set Screw, M4x5	2	16, 17
PV0552	Linkage Rod, E550/E620 SE	BK0839	Sus Linkage Rod, M2.3x30	2	9
		BK0840	Sus Linkage Rod, M2.3x46	2	19
		BK0842	Sus Linkage Rod, M2.3x76	2	13
		BK1120	Sus Linkage Rod, M2.3x130	2	18
		BK1121	Sus Linkage Rod, M2.3x107	2	19
PV0553	Frame Spacer, E550/E620 SE	BK1111	Frame Spacer (44mm)	11	5
PV0554	Elev. Arm Lever, E550/E620 SE	BK1102	Elev. Arm Lever, E550/E620 SE	1	6
		BK0075	Linkage Ball	2	6
		HMJ2-10N	Self-tapping Screw, M2x10	2	6
PV0555	Elev. A Arm, E550/E620 SE	BK1101	Elev. A Arm, E550/E620 SE	1	6
PV0556	Aileron Lever, E550/E620 SE	BK1103	Aileron Lever, E550/E620 SE	2	6
		BK0075	Linkage Ball	6	6
		BK0076	Collar (d4xD4x10)	2	6
		HMJ2-10N	Self-tapping Screw, M2x10	6	6
		HSE3-18B	Self-tapping Screw, M3x18	2	6
PV0557	Servo Tray, E550/E620 SE	BK1106	Servo Tray, E550/E620 SE	1	5
		HSE3-12B	Self-tapping Screw, M3x12	4	5
		HSE3-18B	Self-tapping Screw, M3x18	2	5
PV0558	Main Frame, E550/E620 SE	BK1104	Main frame, E550/E620 SE (L)	1	5
		BK1105	Main frame, E550/E620 SE (R)	1	5
		BK1111	Frame Spacer (44mm)	9	5
		HSE3-12B	Self-tapping Screw, M3x12	18	5
		HMC3-20B	Socket Screw, M3x20	2	5
		HMM3Z	Lock Nut, M3	2	5
PV0559	Al Lower Frame, E550	BK1122	Al Lower Frame, E550	2	7
PV0560	Cfrp Lower Frame, E620 SE	BK1107	Cfrp Lower Frame, E620 SE	2	7

Parts No.	Description	Item No.	Description	Quantity	Ref. Step
PV0561	Bottom Frame, E550/E620 SE	BK1108	Bottom Frame, E550/E620 SE	1	7
PV0562	Battery Bracket, E550/E620 SE	BK1109	Battery Bracket, E550/E620 SE	1	7
PV0563	Skid Adaptor, E550/E620 SE	BK1110	Skid Adaptor, E550/E620 SE	4	7
		HMJ3-22B	Self-tapping Screw, M3x22	4	7
		HSE3-18B	Self-tapping Screw, M3x18	4	7
PV0564	Decal, E550	JV0179	Decal, E550	1	-
PV0565	Decal, E620 SE	JV0180	Decal, E620 SE	1	-
PV0572	Velcro	BK1125	Velcro	2	20
PV0574	Motor Mount, E550/E620 SE	BK1114	Motor Mount	1	10
		HMC3-6B	Socket Screw, M3x6	4	10
		HMC3-10B	Socket Screw, M3x10	4	10
		BK0087	Flat Washer	4	10

HELICOPTER ACCESSORIES



2379 BL MOTOR, OBL 43/11-30H



2380 BL MOTOR, OBL 49/08-50H



3800 BLADE SUPPORT



3802 PRECISION PITCH GAGE



8126 DIGITAL SERVO, DS1213

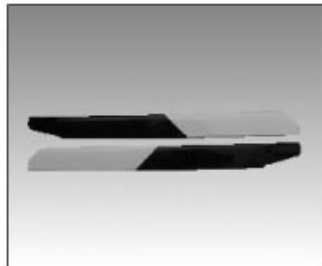

3827/3829 CF ROTOR BLADE,
600mm/620mm



8042 SPEED CONTROL,
BLC-65 2-10 CELLS

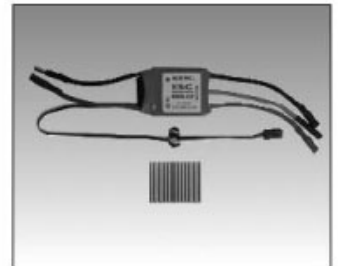

8043 SPEED CONTROL,
BLC-75 2-6 CELLS

OPTIONAL PARTS



PV0099 CARBON TAIL BOOM, R30/E550
PV0523 CARBON TAIL BOOM, R50T/E620

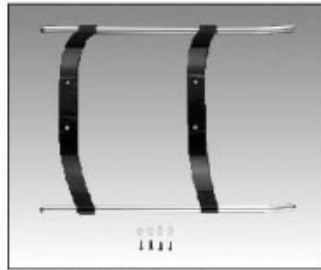

PV0101 CARBON SKIDS

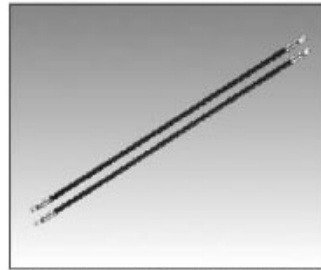

PV0103 CB TAIL BOOM BRACE



PV0339 METAL ROTOR GRIP

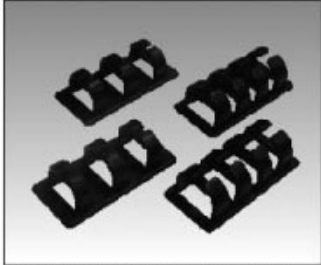

PV0384 WIRE CLAMP, HELI

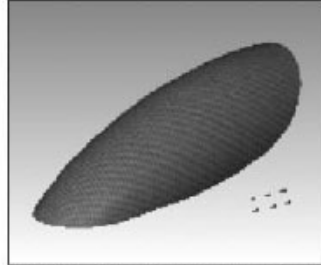

PV0394 SIM-CARBON CANOPY



PV0399 MAIN ROTOR GRIP POST

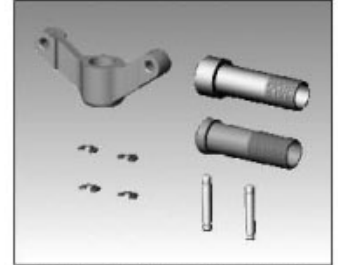

PV0439 M.TAIL PITCH FORK (AL)



PV0442 METAL MIXING LEVER SET



PV0443 STABILIZER CONTROL SET



PV0444 FLYBAR CONTROL ARM SET



PV0445 METAL WASHOUT ASSEMBLY

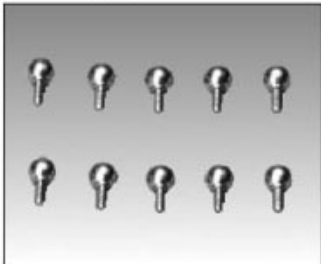

PV0448 SOCKET LINK BALL SCREW



PV0449 ROTOR GRIP PLATE SET



PV0457 TAIL SLIDER



PV0481 LIGHT PADDLE

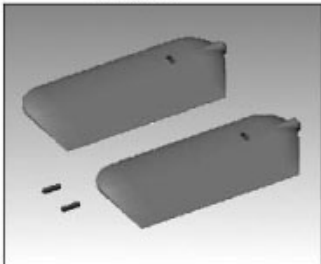

PV0482 ULTRA LIGHT PADDLE

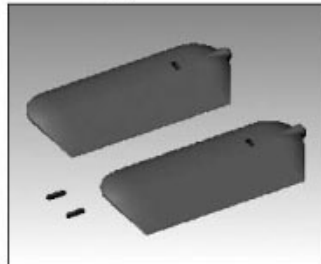

PV0482-R ULTRA LIGHT PADDLE(RED)

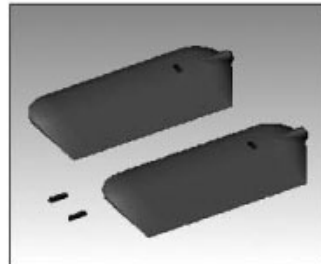

PV0482-L ULTRA LIGHT PADDLE(BLUE)

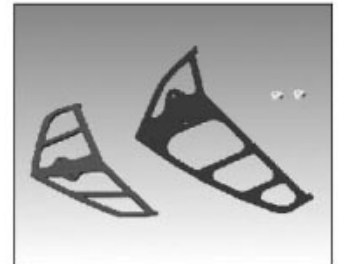

PV0483 CARBON TAIL FIN SET



PV0484 M.BUTTON ROTOR HUB

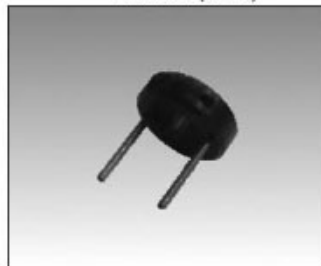

PV0492 ROTOR HUB SLIDER RING



PV0499 SUS TAIL HUB

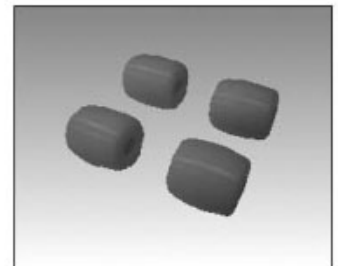

PV0512-Y SKID DAMPER(Y)

OPTIONAL PARTS

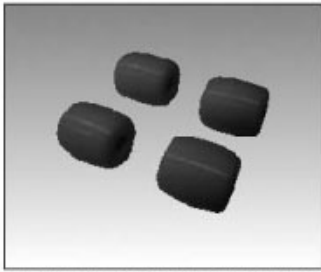

PV0512-L SKID DAMPER(BLUE)



PV0512-W SKID DAMPER(W)



PV0547 MOTOR PINION, 11T



PV0548 MOTOR PINION, 12T



PV0549 MOTOR PINION, 13T



PV0566 90°/140° SWAHPLATE,
E550/E620

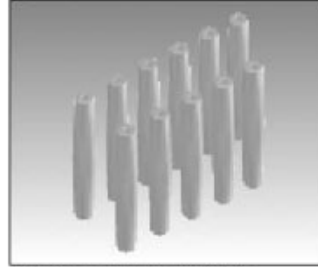

PV0567 METAL FRAME
SPACER, 44mm



PV0568 AL AILE LEVER,
E550/E620



PV0569 ELEV. ARM LINK,
E550/E620



PV0570 CB HORZ. TAIL FIN



PV0571 CB VERT. TAIL FIN



PV0573 M. WASHOUT BASE,
E550/E620



E550

Full length of fuselage	1150mm(45.27")
Full width of fuselage	140mm(5.51")
Total height	390mm(15.35")
Main rotor dia.	1245mm(49")
Tail rotor dia.	237mm(9.33")
Gear Ratio	1:8.54~12.33:4.56
Full equip. weight	3300g(7.3lb)

E620 SE

Full length of fuselage	1220mm(48.03")
Full width of fuselage	140mm(5.51")
Total height	390mm(15.35")
Main rotor dia.	1345~1385mm(52.95"~54.53")
Tail rotor dia.	237mm(9.33")
Gear Ratio	1:8.54~12.33:4.56
Full equip. weight	3500g(7.7lb)



THUNDER TIGER CORP. www.thundertiger.com

JK0181

Printed in Taiwan