

SPECIFICATION / 規格表

Fuselage Length / 全長:	1200mm (47.24")
Fuselage Width / 全寬:	200mm (7.87")
Main Rotor Diameter / 主旋翼旋轉直徑:	1345mm (52.95")
Main Rotor Length / 主旋翼長度:	600mm (23.62")
Tail Rotor Length / 尾旋翼長度:	95mm (3.74")
Tail Rotor Diameter / 尾旋翼旋轉直徑:	260mm (10.24")
Gear Ratio / 齒輪傳動比:	1:8.5:5
Fully Equipped Weight / 全配重量:	3,250g / 7.16 lbs. (w/o fuel)
Fuel Tank Capacity / 油箱容量:	420cc
Header Tank Capacity / 副油箱容量:	60cc

FEATURES / 特色

- | | |
|---|--|
| <ol style="list-style-type: none"> 1. Efficient torque tube drive system for crisp rudder response & 100% power transfer. 2. Lightweight, machined metal tail case (weighs only 26 grams). 3. High-precision, under-slung metal rotor head for awesome 3D performance. 4. Compound carbon/aluminum tail boom to reduce vibration. 5. Lightweight metal tail boom bracket. 6. Hardened 10mm main shaft, 7mm feathering shaft & 5mm tail output shaft. 7. Lengthened receiver tray for receiver LiPo battery. 8. One-piece carbon frame with slim profile (only 30mm wide). 9. Dual radial, single thrust bearings and metal tail grips with 95mm blades. 10. Lightweight and vented clutch bell / Metal-reinforced ribs. 11. Lightweight and vented main and tail gear set design. 12. Lightweight and rugged landing skid. 13. Carbon base plate and carbon fin. 14. Shrouded fan for efficient heat dissipation. 15. Spacious 3-deck tray for electronic devices. 16. Main and header tanks (total capacity: 480 cc). 17. High-quality, Color stream preprinted fiberglass canopy. 18. Lightweight paddles for 3D (weigh only 20 grams) 19. +/- 15° Collective & +/- 25° cyclic travel. | <ol style="list-style-type: none"> 1. 高效率尾軸傳動系統 2. 一體成型輕量化鋁削尾座 (僅26公克重) 3. 高精度全金屬旋翼頭組 4. 碳纖/鋁質複合材尾管, 有效降低震動 5. 金屬輕量化尾支撐桿固定座 6. 強化10mm主軸, 7mm橫軸及5mm尾橫軸 7. 加長型接收機座, 方便使用接收機鋰電池 8. 單片式窄機身碳纖側板設計 (僅30mm寬) 9. 標準95mm尾旋翼搭配雙滾珠軸承包覆止推軸承 10. 輕量化鏤空離合器罩及機身金屬強化肋條 11. 輕量化鏤空主齒盤及尾傳動齒輪組 12. 高強度輕量化腳架 13. 碳纖強化底板及碳纖垂直安定翼 14. 高效率包覆式散熱風扇罩 15. 三層式電子設備固定座設計 16. 加大主油箱, 含副油箱容量達480cc 17. 原廠塗裝完成變色龍亮彩玻纖機頭罩 18. 標準配備20克3D版輕量化平衡翼 19. 主旋翼攻角達+/-15度, 舵面行程量+/-25度 |
|---|--|



Titan X50 INSTRUCTION MANUAL

Torque-tube Version 組裝說明書



No.4856

Manufactured by THUNDER TIGER CORP.
www.thundertiger.com

© 2011

JK0362V2



This radio control model is not a toy! Before beginning assembly, please read this manual thoroughly.
本產品為高性能模型非一般玩具, 組裝與操作前請詳閱本產品說明書。

The contents are subject to change without prior notice due to product improvements and specification changes.
本套件所附之零件可能跟圖示有所差異。因產品後續之設計研發或功能不斷改善之原因, 我們將保留產品規格變更權力, 不再另行通知使用者。

Titan X50

Torque-tube Version

CONTENTS

INTRODUCTION

Intro & Caution / 簡介與注意事項	2
Other Items Required / 其餘必須配件	4
Assembly / 組裝步驟	6
Main Rotor / 主旋翼機構組裝	6
Main Rotor Head Linkage Rod Installation / 主旋翼頭連桿組裝	11
Tail Boom Bracket Assembly / 尾管固定座組裝	12
Main Frame Assembly / 本體組裝	13
Engine Assembly / 引擎動力組裝	16
Landing Skid Assembly / 腳架組裝	18
Tail Unit Assembly / 尾旋翼組裝	23
Tail Boom Assembly / 尾管組裝	25
Servo Installation / 伺服機裝配	26
Servos Linkage Rod Installation / 伺服機連桿組裝	27
Receiver & Gyro Configuration / 接收機與陀螺儀配置	28
Main Rotor Blade Assembly / 主旋翼組裝	29
Set-up Section / 設定程序說明	30
Engine Throttle Control Linkage / 引擎的飛行前調整	30
Electric Device Connection / 電子設備連接說明	30
Configuring The Titan X50 / Titan X50 設定	31
Radio and Control Linkage Setup For Titan X50 / 遙控器設定	32
Collective Pitch Setup / 螺距設定	32
Setting Up Data For Your Reference / 參數設定參考	33
Tail Control And Gyro Setup / 尾舵控制及陀螺儀控制	34
Swashplate Type Setting / 十字盤模式設定	35
Swashplate & Servo Movement Setting / 十字盤及伺服機動作設定	35
Blade Tracking Adjustment / 主旋翼軌跡調整	36
After Flight Checklist / 飛行後的檢查項目	37
Trouble Shooting / 異常處置	37
Spare Parts List / 維修零件包表格	39
Optional Parts / 改裝零件表	52
Exploded View / 爆炸圖檢索	53

INTRODUCTION / 簡介

Thank you for purchasing the Thunder Tiger Titan X50 engine R/C helicopter. This new helicopter is the latest innovation by Thunder Tiger. It has the perfect combination of flying stability and the agility for 3D flying. This helicopter is an excellent choice for flying enthusiasts like you. For convenient assembly and safe operation of the helicopter, please read the instructions carefully. Retain the user manual in case you need it for any information or reference.

感謝您購買雷虎科技Titan X50直昇機產品，本項產品為雷虎科技全新開發機種，兼具高度穩定性與3D飛行特性，是熱衷引擎直昇機的您不可錯過的選擇。請於使用本產品前詳盡閱讀使用手冊，以利於組裝工作順暢進行與安全操控本產品。請妥善保存使用說明書，以利後續調整與維修參考用途。

CAUTION / 警告

1. R/C models are not toys. This product is a high-precision flying machine. Possibilities of unexpected crashes may occur due to electronic interference, incorrect operation, or poor mechanical maintenance. Although it is a small-sized helicopter, the rotor blades rotate at high speeds, which may cause serious damage, injury, or death if the model hits people or property. Therefore, extreme caution must be exercised during operation.
2. Thunder Tiger ensures parts packaged in this product is of the highest quality. However, after assembly and usage, parts damaged due to wear or misuse will not be replaced under any circumstances. If you have any questions regarding its operation and repair, Thunder Tigers service agents are able to provide free technical guidance.
3. This product is only recommended for users ages 16 and up. Because flying a R/C helicopter is difficult, beginners must receive guidance and supervision from experienced pilots to minimize unexpected danger. Practice in spacious areas, far away from obstacles such as buildings, trees, electrical towers, or crowds.
4. To decrease the cost of repair and maintenance for beginners, it is recommended to fly the helicopter with a practice rack and to learn basic flying skills with a computer R/C flying simulator. (Crashes in simulators are free to repair!)
1. 本項遙控直昇機產品並不是玩具，是一項結構精密、高專業度模型產品，如果未經正確組裝與操控，將可能對操控者或其他人造成身體傷害。使用者必須了解，若未確實進行飛行前安全檢查或操控不當，而造成人員受傷或物體損壞，使用者必須負起法律責任。
2. 本產品由高品質零組件組成，雷虎科技對於安裝過程、使用過後..等人為因素造成損壞事件不負損壞賠償之責。如您需要本產品相關組裝、調整或其他協助，可與雷虎科技全省經銷商聯繫。
3. 本項產品禁止十六歲以下青少年與孩童使用。強烈建議初學者應取得技術支援後再進行飛行，以避免危險發生。請於空曠地區操控本產品，並避免於建築物、樹木、電塔..等障礙物區域飛行。
4. 建議初學者可安裝練習架或透過電腦模擬軟體練習，可達到實際練習效果與符合經濟效益。

AMA INFORMATION / 特別注意事項

Operating a model helicopter requires a high degree of responsibility and skill. If you are a newcomer to the hobby, it is best to seek help and guidance from accomplished model helicopter pilots. This will greatly speed up the learning process and have you flying successfully in a reasonable amount of time. We also would strongly urge you to join the Academy of Model Aeronautics. The AMA is a non-profit organization that provides its members with a liability insurance plan as well as monthly magazine entitled Model Aviation. All AMA charter aircraft clubs require all pilots to hold a current AMA sporting license prior to operation of their models at club fields. For further information, contact the AMA at:

Academy of Model Aeronautics
5151 East Memorial Drive
Muncie, IN 47302
(317) 287-1256

操控遙控直昇機對於飛行安全要求極高，需要高度的負責任態度配合，以及較高的操控技巧。如果您是一位初學者，建議您必須向當地專業模型經銷商，或是遙控直昇機相關組織以及經驗豐富的玩家尋求相關協助，以獲得您所需要的訊息以及專業知識。如此可有效協助您縮短學習的時間，更容易學會遙控直昇機的組裝、設定與操控技巧。

FLIGHT SAFETY CHECKLIST / 飛行前安全確認工作項目

1. Make sure that the transmitter battery is fully charged before flying.
 2. Make sure all control surfaces are operated properly before flying.
 3. Do a range check of the radio before the first flight. The electronic equipment must operate properly at a range of at least 5 meters (18 ft) even with the transmitter antenna collapsed.
 4. Make sure there are no other pilots using the same radio frequency with yours and that there are no other radio interference on your frequency.
 5. Be sure to turn on the transmitter first with the throttle stick in the idle position. Plug the battery into the ESC last.
 6. The main rotor and the tail rotor spin at very high RPM. Make sure nothing can come in contact with the rotor blades during flight.
 7. Always maintain a safe distance from the helicopter during flight.
 8. Never fly the helicopter in the rain or in excessive wind conditions.
 9. Always operate and fly the helicopter in a safe and responsible manner.
 10. Never fly the helicopter over other pilots, spectators, cars or anything that could result in injury or property damage.
1. 確認接收機與發射機電池，均已確實充電完成。
 2. 確認所有操控介面運作順暢。
 3. 確認無其他無線電波干擾，且不與其他同好同時使用相同頻率。
 4. 確實將油門搖桿放置於低速，再將發射機電源開啟，然後再將電池接上。
 5. 確認遙控器發射器與接收機工作正常，將機體放至於距離5公尺外，確認遙控器是否正常，機體控制動作是否正確。
 6. 主旋翼與尾旋翼轉速相當高，運轉時須避免任何障礙物與旋翼接觸。
 7. 飛行時，需與遙控直升機保持安全距離。
 8. 勿於下雨天或是強風的狀態下操控遙控直升機。
 9. 請以安全為第一考量，並以高度負責任的態度參與遙控直升機活動。
 10. 禁止於人群、車輛..或任何其他障礙物上方飛行遙控直升機，避免意外發生。

POST FLIGHT INSPECTION / 飛行結束安全檢查事項

1. Inspect the model thoroughly to insure no parts have come loose or become damaged during the flight and landing. Replace damaged parts and tighten loose screws before flying again.
 2. Clean the helicopter body.
 3. Lubricate all moving parts to ensure smooth operation for the next flying.
 4. Replace any worn ball links and damaged bearings.
 5. Store the model in a cool, dry place. Avoid putting it under direct sunlight or near a source of heat.
- Following these simple rules will allow you to enjoy the thrill of model helicopter flying for many years.
1. 飛行結束後確認機體所有的零件與螺絲是否有損壞或鬆動，更換損壞零件與確實固定鬆動的螺絲。
 2. 機體清潔乾淨。
 3. 檢查所有活動零組件是否運作順暢，以利下次飛行。
 4. 更換所有鬆動的連桿、接頭，以及損壞的軸承。
 5. 將機體存放於陰涼通風處，避免機體放置於陽光直射處或接近熱源。
- 確實執行上述幾項簡單的步驟，將可確保您的愛機維持數年的壽命！

CAUTION / 注意事項

When the model has crashed, inspect the flybar, rotor shaft and the blade spindle to make sure they are not bent. If any item is damaged, it must be replaced with a new part to ensure safe operation. Do not glue any broken or damaged plastic parts. Do not repair broken rotor blades. It is very important to inspect the motor, speed control and the battery.

Always inspect the following items:

Gears, Ball links, Link rods, Bearings, Main shaft, Flybar, Spindle, Tail boom and support, Fins, Tail rotor shaft, Belt, Main blades, Tail blades, the Motor, the Speed control and the Battery.

機體一但發生墜落事件，請確實檢查平衡桿、主軸、橫軸是否有彎曲變形，如果有任何的損壞，請立即更換原廠新的零組件，確認機體操作安全！切勿使用任何接著劑嘗試黏合塑膠零件；請勿使用修復過的主旋翼。馬達、速控器、電池的安全檢查工作亦相當重要。

發生機體墜落事件後，請確實檢查下列項目：

齒輪組、球頭連桿、連桿頭、軸承、主軸、橫軸、尾軸、平衡桿、平衡片、尾管、尾管支撐架、垂直與水平尾翼、尾驅動輪、皮帶、主旋翼、尾旋翼、馬達、速控器、電池。

OTHER ITEMS REQUIRED 需自行準備的配件

RADIO SET / 遙控系統

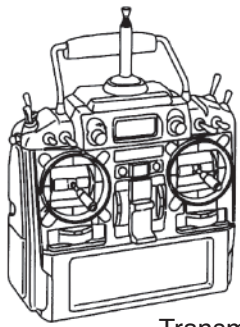

Transmitter (helicopter type only, 6 or more channels)
發射機 (需具備直昇機控制功能的6動以上遙控器)

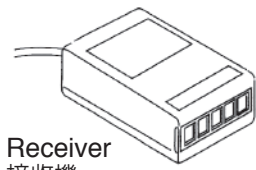

Receiver
接收機

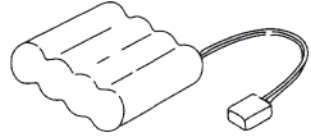

Battery 接收機電池
1000mAh

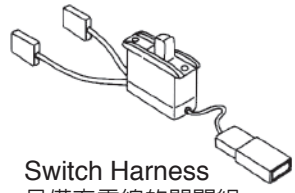

Switch Harness
具備充電線的開關組

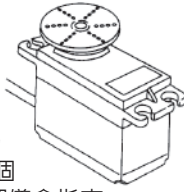

Servo x 5
伺服機x 5個
(部分陀螺儀會指定使用單一規格伺服機)

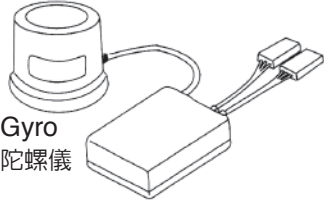

Gyro
陀螺儀

ENGINE / 引擎系統

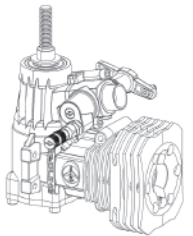

RC Helicopter engine
直昇機專用引擎



Glow Plug
專用火星塞

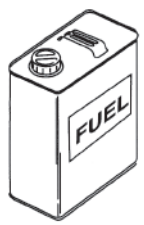

Glow Fuel(15%-30%)
直昇機專用燃油

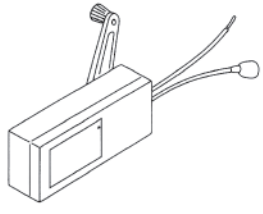

Fuel Pump
加油泵

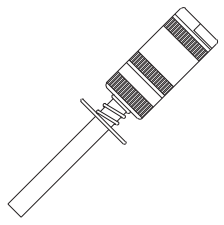

1.5V Glow Starter
(1.2V~1.5V)
1.5V快速電夾

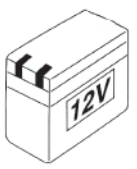

12V Battery
電瓶

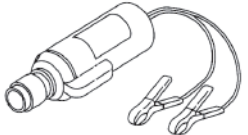

12V Electric Starter
啟動馬達



Rubber Band
橡皮筋

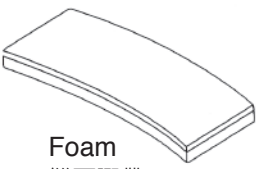

Foam
雙面膠帶

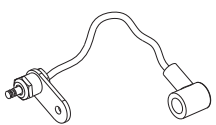

Remote Glow Plug Extension
火星塞外接線
(可視需求自行選擇)



Extended 6mm Hex Starting Tool
啟動棒

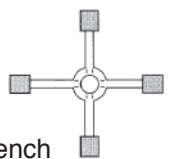

Glow Plug Wrench
可卸火星塞的十字套筒扳手

TOOLS REQUIRED FOR ASSEMBLY 需要準備的工具

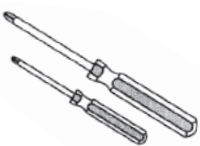

Screw Driver
各種規格的螺絲起子



Needle Nose Pliers
尖嘴鉗



Nipper
斜口鉗

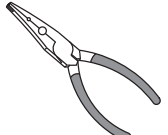

Ball Link Pliers
拆連桿頭的專用鉗子



Scissors
剪刀

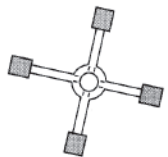

Metric 4-way Wrench
十字套筒扳手

5.5mm
7mm
8mm



Hobby Knife
美工刀



C.A Glue
瞬間膠

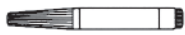

Threadlocker
螺絲防鬆膠



Grease
潤滑油



Epoxy
環氧樹脂

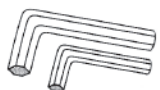

Hex Wrench
六角扳手

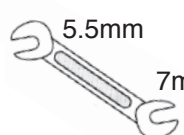

Wrench
開口扳手

5.5mm
7mm

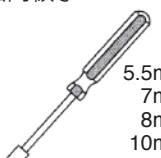

Socket Drivers
套筒螺絲起子

5.5mm
7mm
8mm
10mm

MANUAL FORMAT / 說明書使用方式

How to read the instruction manual? 說明書導讀

- A:** Indicates the assembly step number and the parts bags that are to be assembled.
- B:** Displays actual size drawings, and part quantities used.
- C:** All parts, except screws, are identified by its order numbers. When purchasing spare parts, identify the part required and cross reference this to the spare parts list in the end of this manual, which shows the purchasable spare parts and the corresponding order numbers.
- D:** This instruction manual uses several symbols. Pay careful attention to them during construction. Details are given at the bottom of each page.
- A:** 顯示組立步驟及需組立之零件包順序
- B:** 零件實際對照尺寸及使用數量
- C:** 請比對零件形狀以及後附零件料號對照圖示找出需求零件料號
- D:** 操作說明符號可更有效協助組裝者使用此說明書，請依說明書符號指示進行組裝步驟

Example 說明範例

Bag A Main Rotor-5 / 主旋翼機構組裝-5

No.	Material No.	Description	名稱	Qty.
1	BK1502	HARDENED MAIN SHAFT	高強度主軸	1
2	BK1086	SOCKET SCREW M2x14	六角半牙螺絲M2x14	1
3	HML2	M2 NUT	M2螺帽	2

Step 1 / 步驟一

1. Insert the main rotor head set into the Main Shaft. Note the end with a hole of the Main Shaft has to insert into the Hub.
 2. Line up the holes on the Main Shaft & Hub.
 3. Insert the Socket Screw (M2 x 14, #2) through the Hub and apply a drop of threadlocking to screw it with the Nut.
 1. 將主軸穿過組裝完成的主旋翼頭組。
 2. 對正主軸及頭座上孔位。
 3. 以半牙內六角螺絲穿過頭座及主軸後，套上螺帽並使用適量防鬆劑固定。

The hole should point up.
請注意，有孔位的一端應朝上。

SYMBOLS USED THROUGHOUT THE MANUAL / 符號說明

The parts in the Titan X50 are packed according to each major assembly steps. The part number and quantity are always shown in the square box on each page. As good practice, only open up the bag that you need for the particular assembly. 零件均依照組裝步驟包裝，請依照組裝程序，逐一開啟零件包，避免零件遺失。

Note / 注意

Assembly drawings will contain icons that indicate use of Threadlocker or CA glue as needed. Examples of the icons are as right shown: 請依組裝步驟圖示，使用防鬆膠或接著劑。圖示範例如右：

- T22(#262) → THREADLOCKER / 螺絲防鬆膠
- CA → CA GLUE / 快乾膠

<ul style="list-style-type: none"> Apply C.A Glue 使用快乾膠黏合 Apply threadlocker 使用螺絲防鬆膠 Assemble as many times as specified 依指示組裝所需數量 Assemble left and right side the same way 左右側組件相同 Assemble in right order 依標示順序組裝 	<ul style="list-style-type: none"> Cut off shaded portion 依標示部分裁切 Ensure smooth, non-binding movement when assembling 確認組件靈活度 Drill holes with the specified diameter 依標示尺寸鑽孔 Must be purchased separately 改裝品需另購 	<ul style="list-style-type: none"> Cut off excess 裁剪多餘部分 Apply grease 使用潤滑油膏(黃油) Pay close attention here 注意組裝步驟 Hint 組裝提示
--	---	--

Bag A Main Rotor-1 / 主旋翼機構組裝-1

No.	Material No.	Description	名稱	Qty
1	BV2181	METAL MAIN ROTOR HUB	金屬主旋翼固定座	1
2	BV2186	METAL SEESAW HUB	金屬穩定桿固定座	1
3	BK2187	COLLAR,d3xD4xW3.8	軸環,d3xD4xW3.8	2

No.	Material No.	Description	名稱	Qty
4	HSA3-10	BUTTON HEAD SOCKET SCREW,M3x10	半圓頭內六角螺絲,M3x10	2
5	HMC25-8B	SOCKET SCREW,M2.5x8	內六角螺絲,M2.5x8	1
6	BK2182	METAL HEAD BUTTON	金屬旋翼頭制動器	1

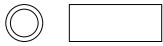

BK2187
COLLAR,d3xD4xW3.8
軸環,d3xD4xW3.8

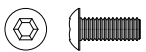

HSA3-10
BUTTON HEAD SOCKET SCREW,M3x10
半圓頭內六角螺絲,M3x10

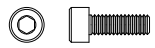

HMC25-8B
SOCKET SCREW,M2.5x8
內六角螺絲,M2.5x8

Step 1 / 步驟一

- Slide the Metal Seesaw Hub into the Main Rotor Hub.
 - Note the orientation of the Metal Seesaw Hub.
1. 將主旋翼固定座穿過穩定桿固定座。
2. 注意穩定桿固定座安裝方向。

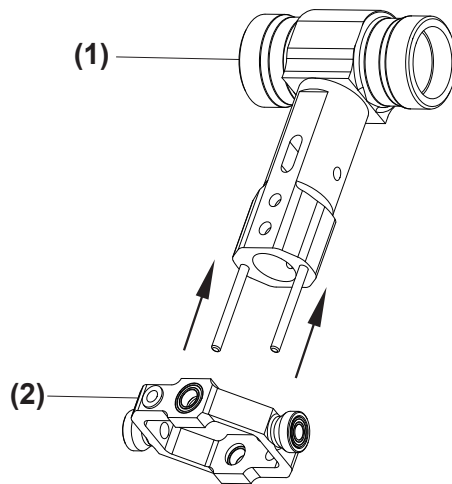

Step 2 / 步驟二

- Rotate the Metal Seesaw Hub toward for 90 degree.
 - Note the orientation of the Chamfer on the Metal Seesaw Hub.
1. 90度旋轉穩定桿固定座。
2. 注意金屬穩定固定座倒角方向。

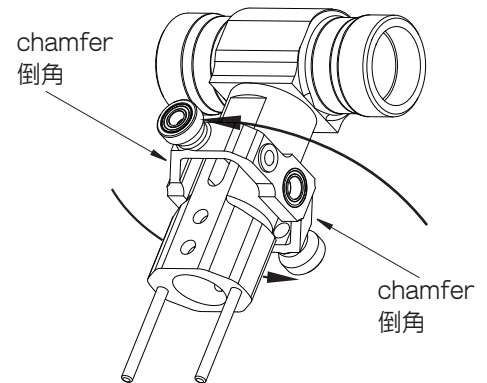

Step 3 / 步驟三

Fit the Collar into the bearings, tighten the screws and ensure the Metal Seesaw Hub runs effortlessly.
如圖示，鎖緊固定螺絲，並確認穩定桿固定座能自由活動。

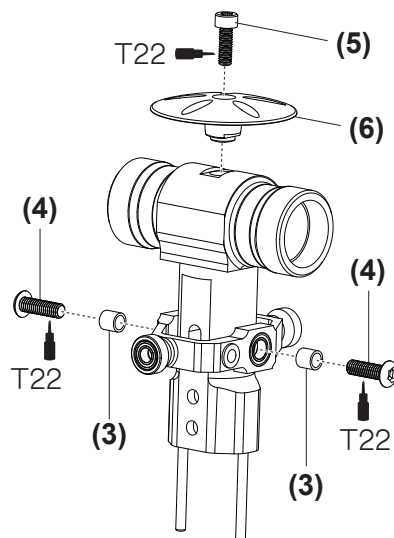

Completed View 組裝完成

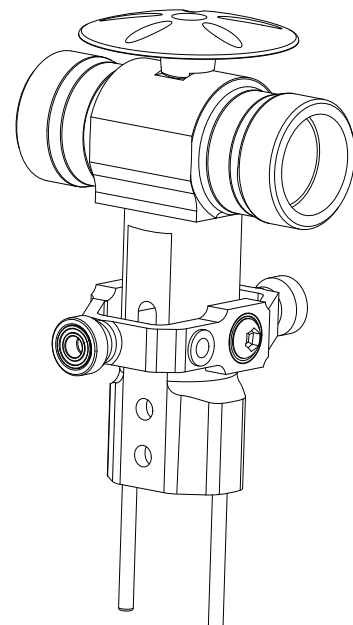

Apply threadlocker
使用螺絲防鬆膠

No.	Material No.	Description	名稱	Qty
1	BV2183	METAL MIXING LEVER	金屬混控臂	2
2	BK0649-1	LINKAGE BALL (A)	內六角連接頭螺絲 (A)	4

No.	Material No.	Description	名稱	Qty
3	BK0077	COLLAR, d3xD4xW6	軸環, d3xD4xW6	2
4	HSA3-10	BUTTON HEAD SOCKET SCREW, M3x10	半圓頭內六角螺絲, M3x10	2

BK0077
COLLAR, d3xD4xW6
軸環, d3xD4xW6

BK0649-1
LINKAGE BALL (A)
內六角連接頭螺絲 (A)

HSA3-10
BUTTON HEAD SOCKET SCREW, M3x10
半圓頭內六角螺絲, M3x10

Step 1 / 步驟一

Secure the Linkage Balls to the Mixing Lever.

依圖示，安裝控制臂球頭，並適量使用螺絲防鬆劑。

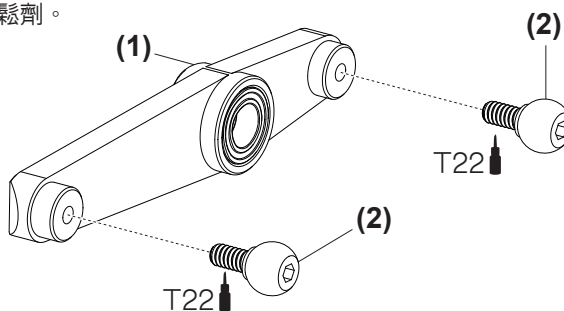

Assemble left and right side the same way
左右側組件相同

Step 2 / 步驟二

1. Secure the Metal Mixing Lever to the Metal Seesaw Hub.
2. Make sure the Metal Mixing Lever runs effortlessly.
1. 將金屬控制臂安裝於金屬穩定桿固定座，並適量使用螺絲防鬆劑。
2. 確認控制臂能自由動作，無干涉及過鬆現象。

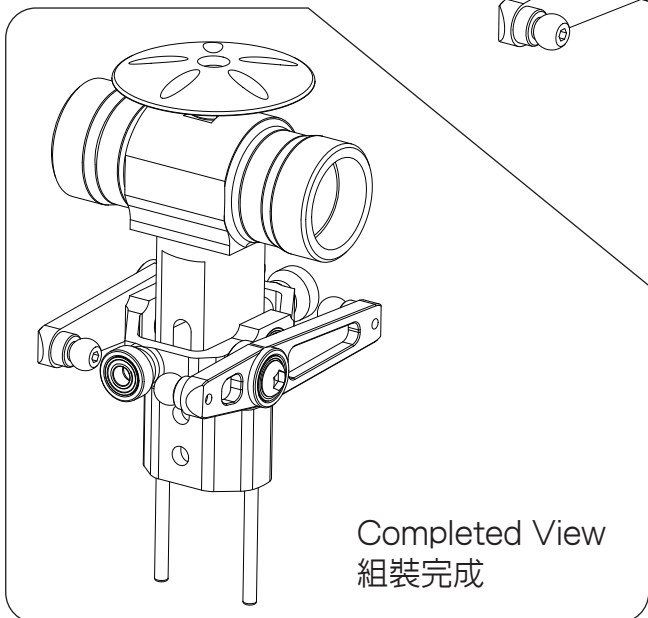
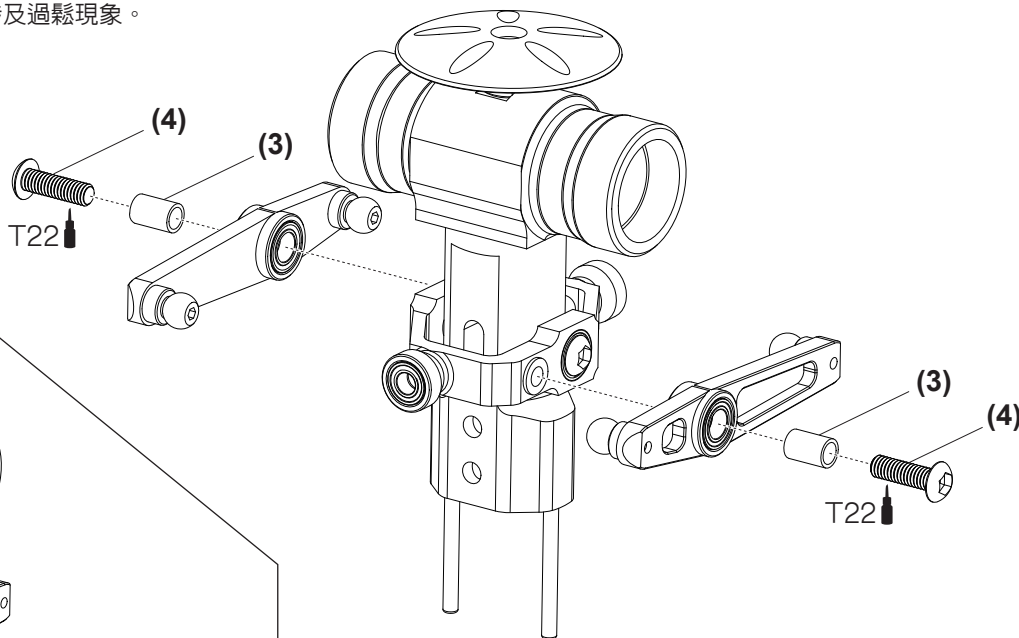

Apply threadlocker
使用螺絲防鬆膠

No.	Material No.	Description	名稱	Qty
1	BK2184	METAL FLYBAR CONTROL ARM	金屬穩定翼轉臂	2
2	BK2185	METAL FLYBAR CONTROL ARM POST	金屬穩定翼轉臂支柱	2
3	HMC2510B	SOCKET SCREW, M2.5×10	內六角螺絲, M2.5×10	2
4	HME4-5B	SET SCREW, M4x5	無頭內六角螺絲, M4x5	2

No.	Material No.	Description	名稱	Qty
5	BK0649-1	LINKAGE BALL(A)	內六角連接頭螺絲(A)	2
6	BK0631	SUS FLYBAR	穩定桿	1
7	HME3-10B	SET SCREW, M3x10	無頭內六角螺絲, M3x10	2
8	BK0067L	FLYBAR PADDLE(BLUE)	穩定翼(藍)	2

BK0649-1
LINKAGE BALL(A)
內六角連接頭螺絲(A)

HME4-5B
SET SCREW, M4x5
無頭內六角螺絲, M4x5

HME3-10B
SET SCREW, M3x10
無頭內六角螺絲, M3x10

Step 1 / 步驟一

1. Secure the Linkage Ball to the Metal Flybar Control Arm.
 2. Assemble the Metal Flybar Control Post and the Flybar Control Arm.
1. 牢固的將球頭安裝於金屬穩定翼轉臂上。
2. 將金屬穩定翼轉臂柱及穩定翼臂裝配完成。

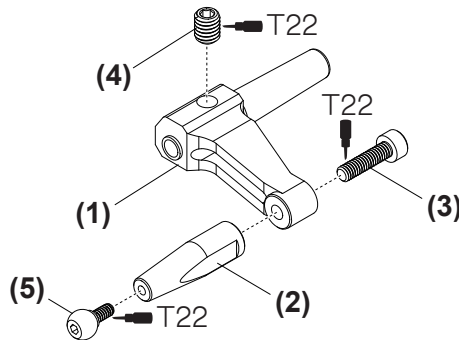

LR Assemble left and right side the same way
左右側組件相同

Apply threadlocker
使用螺絲防鬆膠

Step 2 / 步驟二

1. Insert the Flybar Rod through the Flybar Control Arms & the Metal Seesaw Hub.
 2. Ensure the Flybar Rod have equal protrusion from each side of the Metal Flybar Control Post.
 3. Line up the holes of the Flybar Control Arms and the flat spot of the Flybar Rod, and then screw the Flybar Control Arms & the Flybar Rod tightly.
1. 將穩定桿穿過穩定翼控制臂、金屬穩定桿固定座和金屬旋翼固定座。
2. 確認穩定桿凸出金屬穩定翼控制臂柱兩側等距。
3. 對正穩定翼控制臂上鎖固孔與穩定翼桿上平面凹槽後，再鎖緊螺絲。

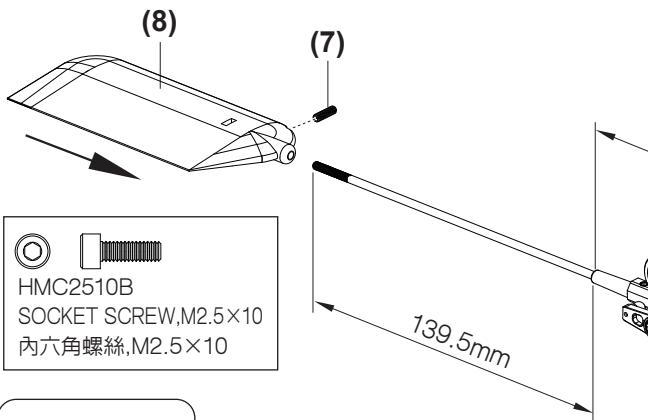
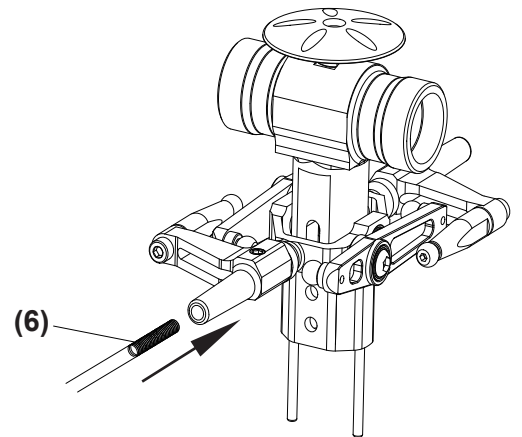

HMC2510B
SOCKET SCREW, M2.5×10
內六角螺絲, M2.5×10

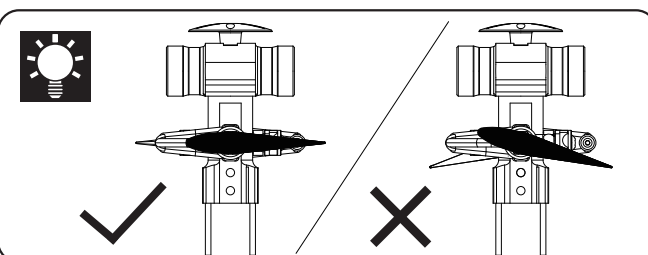
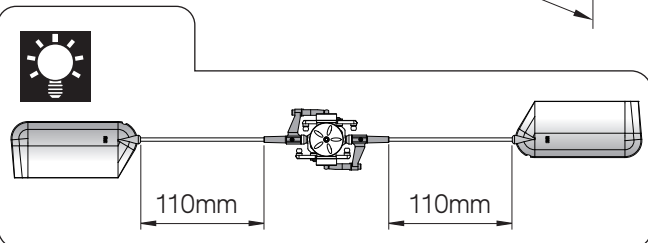

Step 3 / 步驟三

1. Thread the Paddles onto the Flybar Rod, equal the length to the Flybar Control Arms of each side.
 2. Ensure the leading edges of the Paddles are toward the same side to the Metal Flybar Control Posts.
 3. Line up the Paddles with the Flybar Control Arms.
1. 旋上穩定翼於穩定翼桿上，確認兩側的穩定翼至控制臂距離相等。
2. 確認穩定翼前緣與穩定翼控制轉臂方向相同。
3. 對正穩定翼與穩定翼控制臂呈水平狀態。

No.	Material No.	Description	名稱	Qty
1	BV2574	METAL MAIN ROTOR GRIP SET	金屬旋翼轉座組	2
2	BK2579	METAL ROTOR GRIP LEVER	金屬轉座擺臂	2
3	BK2578	METAL ROTOR GRIP POST	金屬連接座	2
4	HMC3-8B	SOCKET SCREW, M3x8	內六角螺絲, M3x8	2
5	BK0649-1	LINKAGE BALL (A)	內六角連接頭螺絲(A)	2
6	HSA3-6	BUTTON HEAD SOCKET SCREW, M3x6	半圓頭內六角螺絲, M3x6	4
7	BK2216	THRUST WASHER, d10xD13xW0.5	止推墊片, d10xD13xW0.5	2
8	HMX0612	THRUST BEARING, d6xD12xW4.5	止推軸承, d6xD12xW4.5	2

No.	Material No.	Description	名稱	Qty
9	BK2214	HARDENED FEATHERING SHAFT	強化固定軸(D7)	1
10	BK2573	OUTER DAMPER, 7mm	外避震墊圈, 7mm	2
11	BK2572	INNER DAMPER, 7mm	內避震墊圈, 7mm	2
12	BK2525	FLAP COLLAR, d7xD10xW1.5	避震軸環, d7xD10xW1.5	2
13	BK0435	WASHER, d4xD11xW1.7	墊圈, d4xD11xW1.7	2
14	HMC4-8B	SOCKET SCREW M4x8	內六角螺絲M4x8	2
15	HMV1370ZZWY	BEARING, d7xD13xW5	滾珠軸承, d7xD13xW5	4

HMC3-10B
SOCKET SCREW, M3x10
內六角螺絲, M3x10

BK0649-1
LINKAGE BALL (A)
內六角連接頭螺絲(A)

BK2525
FLAP COLLAR, d7xD10xW1.5
避震軸環, d7xD10xW1.5

HMC4-8B
SOCKET SCREW M4x8
內六角螺絲M4x8

HMX1370ZZWY
BEARING, d7xD13xW5
滾珠軸承, d7xD13xW5

BK2216
THRUST WASHER, d10xD13xW0.5
止推墊片, d10xD13xW0.5

1. Secure the Linkage balls to the Main Rotor Grips.
2. Insert the Flap Damper into the Main Rotor Hub.
3. Insert the Feathering Shaft through the Flap Dampers & the Main Rotor Hub with some amount of silicon oil or Vaseline. Center the Feathering Shaft in the Main Rotor Hub.
4. Apply Loctite on the Socket Screw (M4x 8), and then secure the Main Rotor Grips on the Feathering Shaft with bearings & washers tightly.

1. 將連桿接頭固定於主旋翼夾座。
2. 將旋翼橫軸避震套環置入主旋翼夾座內。
3. 可塗抹些許矽膠油脂或凡士林於旋翼橫軸避震套環上，以便安裝。
4. 依圖示，組裝金屬主旋翼固定座，使用M4X8內六角螺絲鎖入橫軸時需使用螺絲防鬆膠。

HMX0612
THRUST BEARING, d6xD12xW4.5
止推軸承, d6xD12xW4.5

Assemble the main rotor pitch housing as drawing
主旋翼轉座組裝示意圖

(15) (15) (7) (8)

The bearings (#15) come with the grips which had been assembled by Factory.
主旋翼夾座內軸承 (#15) 已由原廠壓配完成。

Diagram for Thrust Bearing Assembly
止推軸承安裝示意圖

Large Internal Diameter always go toward the Main Rotor Hub
內徑較大的一側，面向主旋翼中心座組。(內側)

Small Internal Diameter always go toward the Blade
內徑較小的一側，面向主旋翼組(外側)。

Checking Tips: $\theta_A > \theta_B$
轉動角度: $\theta_A > \theta_B$
(轉動角度大者，內孔大; 轉動角度小者，內孔小)

HSA3-6
BUTTON HEAD SOCKET SCREW, M3x6
半圓頭內六角螺絲, M3x6

BK0435
WASHER, d4xD11xW1.7
墊圈, d4xD11xW1.7

Completed View
組裝完成

Apply grease
使用潤滑油膏(黃油)

Apply threadlocker
使用螺絲防鬆膠

No.	Material No.	Description	名稱	Qty
1	BK2289	HARDENED MAIN SHAFT	強化主軸	1
2	BK0616	SOCKET SCREW,M3x20	內六角螺絲(半牙),M3x20	2
3	HMM3Z	NYLON NUT,M3	止鬆螺帽,M3	2
4	BV2188A	METAL SWASHPLATE	金屬十字盤組	1
5	BK2196	METAL WASHOUT BASE	控制臂座	1
6	BK2199	METAL FLYBAR CONTROL LEVER	金屬穩定翼控制臂	2
7	BK0016-1	WASHOUT LINKAGE	連接座	2

No.	Material No.	Description	名稱	Qty
8	HMV740ZZY	BEARING, d4xD7xW2.5	滾珠軸承, d4xD7xW2.5	4
9	BK0171	PIN	插銷	2
10	HMS15	E RING	E型扣環	2
11	BK0649-1	LINKAGE BALL (A)	內六角連接頭螺絲(A)	2
12	BK0088	WASHER, d3xD5xW0.5	墊片, d3xD5xW0.5	2
13	BK0077	COLLAR, d3xD4xW6	軸環, d3xD4xW6	2
14	HSA3-10	BUTTON HEAD SOCKET SCREW, M3x10	半圓頭內六角螺絲, M3x10	2

BK0616
SOCKET SCREW,M3x20
內六角螺絲(半牙),M3x20

HMM3Z
NYLON NUT,M3
止鬆螺帽,M3

HMS15
E RING
E型扣環

HMV740ZZY
BEARING,d4xD7xW2.5
滾珠軸承,d4xD7xW2.5

HSA3-10
BUTTON HEAD SOCKET SCREW,M3x10
半圓頭內六角螺絲,M3x10

BK0077
COLLAR,d3xD4xW6
軸環,d3xD4xW6

BK0088
WASHER,d3xD5xW0.5
墊片,d3xD5xW0.5

BK0649-1
LINKAGE BALL (A)
內六角連接頭螺絲(A)

BK0171
PIN
插銷

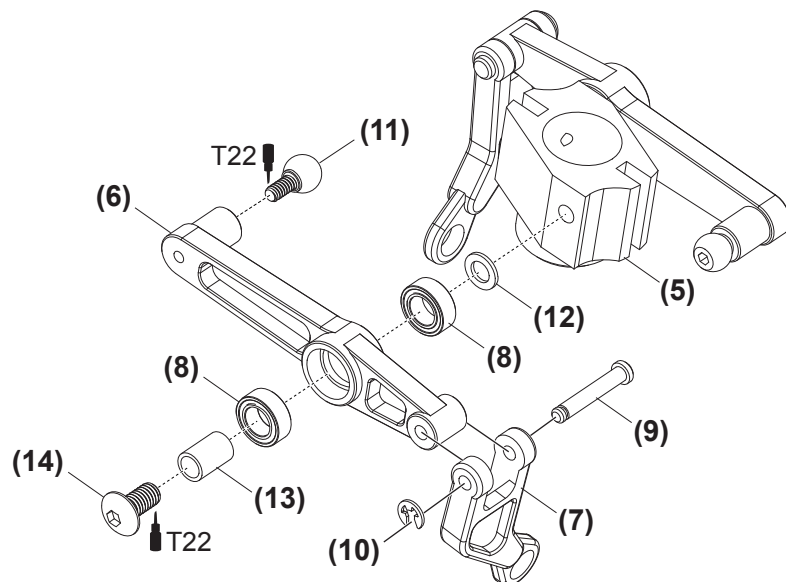
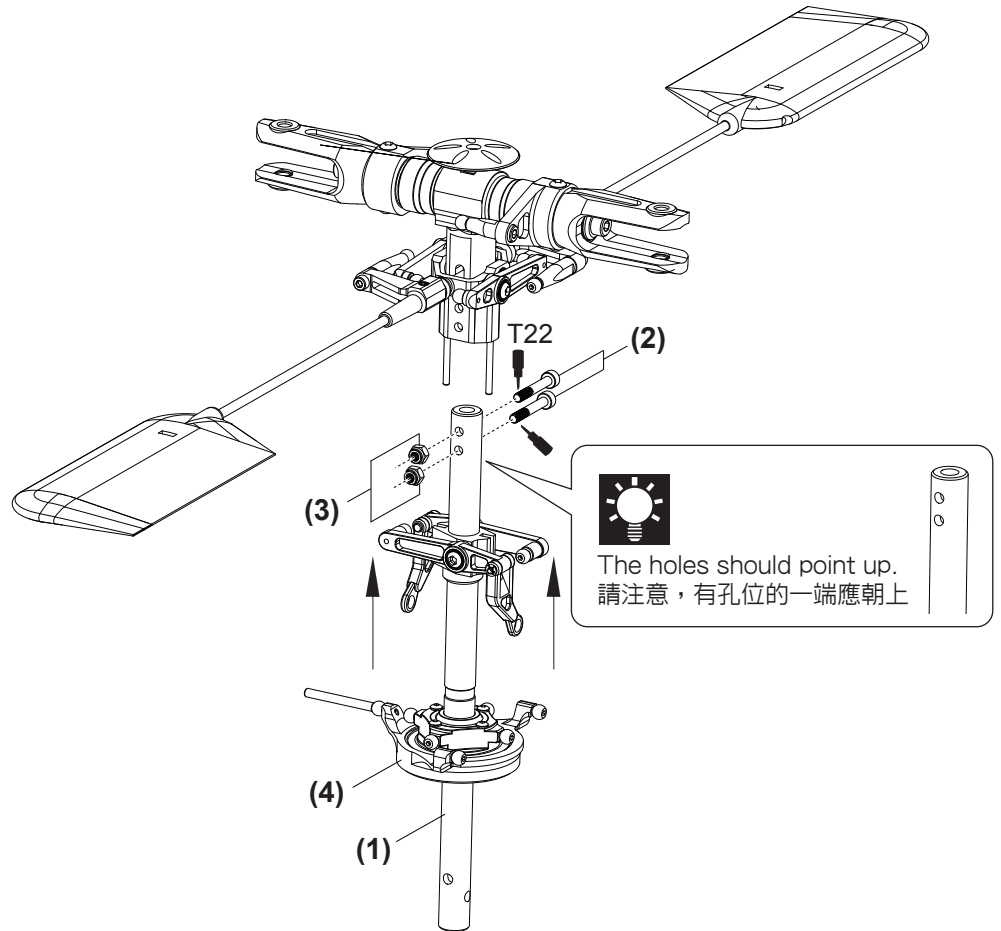

Apply threadlocker
使用螺絲防鬆膠

No.	Material No.	Description	名稱	Qty
1	BK2236	UPPER BRG	上軸承座	1
2	BK2219	FRAME SPACER	六角連接支柱	2
3	HMV6800ZZY	BEARING, d10xD19xW5	滾珠軸承, d10xD19xW5	1
4	BK2206	MAIN SHAFT LOCK RING	止檔圈	1
5	HME4-3B	SET SCREW, M4x3	無頭內六角螺絲, M4x3	2

No.	Material No.	Description	名稱	Qty
6	BK2179	DOUBLE JOINT BALL LINK	雙頭連接桿	2
7	BK2228	FLYBAR JOINT BALL LINK	穩定翼連接桿	2
8	BK2516	LINKAGE ROD, 40mm	連接桿, 40mm	2
9	BK0086	BALL LINK, d4.8x20	單頭連接桿, d4.8x20	4

HMV6800ZZY
BEARING, d10xD19xW5
滾珠軸承, d10xD19xW5

HME4-3B
SET SCREW, M4x3
無頭內六角螺絲, M4x3

BK0086
BALL LINK, d4.8x20
單頭連接桿, d4.8x20



Apply threadlocker
使用螺絲防鬆膠

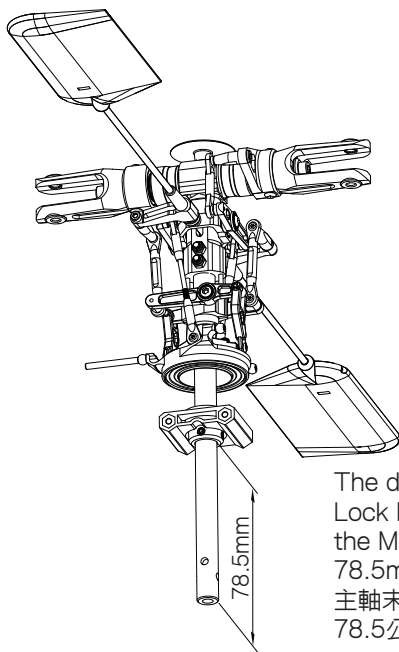
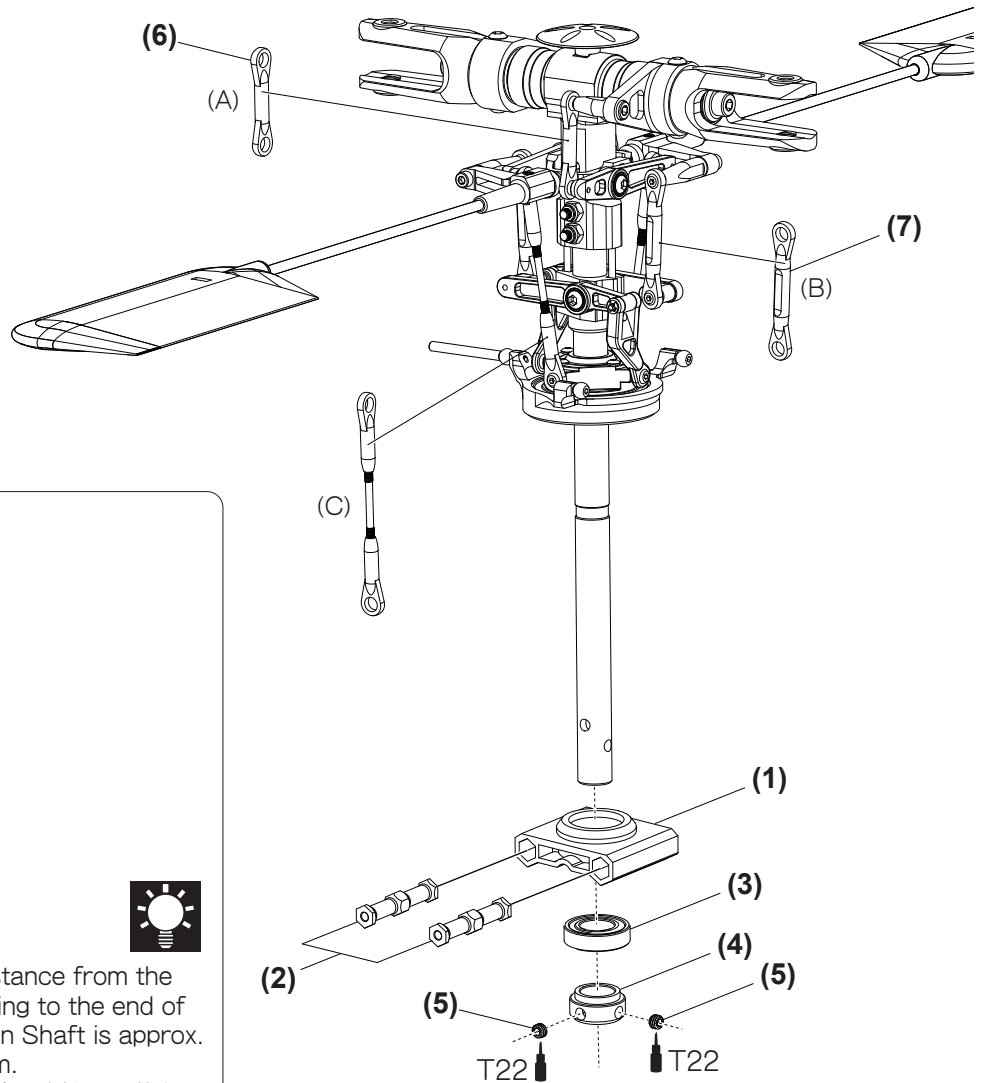

The distance from the Lock Ring to the end of the Main Shaft is approx. 78.5mm.
主軸末端至止檔圈距離為 78.5公釐。



The length may vary when using different servos, please re-adjust the length as actual condition.
搭配不同品牌伺服機時，連桿長度或有不同，調機時，請再依實際狀況進行微調。

Scale=1:1 (unit:mm)

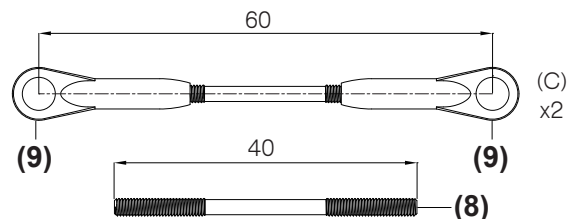
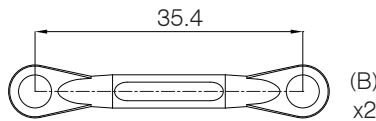
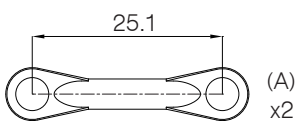

No.	Material No.	Description	名稱	Qty
1	BK2217-L	TAIL BOOM BRACKET-L	尾管固定座(左)	1
2	BK2217-R	TAIL BOOM BRACKET-R	尾管固定座(右)	1
3	BK2219	FRAME SPACER	六角連接支柱	4
4	HMC3-20B	SOCKET SCREW, M3x20	內六角螺絲, M3x20	4
5	HMM3Z	NYLON NUT, M3	止鬆螺帽, M3	4
6	BV2269	TAIL GEAR MOUNT SET	傘齒輪固定座組	1
7	BK2268	TAIL GEAR-B	傘齒輪B-25T	1

No.	Material No.	Description	名稱	Qty
8	BK2509	WASHER, d12xD14.5xW0.2	墊片, d12xD14.5xW0.2	2
9	BV2265	BEARING BLOCK SET	軸傳軸承座組	2
10	BK2267	TAIL GEAR-A	傘齒輪A-25T	1
11	BK2264	TAIL DRIVE GEAR-16T	軸傳尾驅動輪-16T	1
12	BK2266	TAIL DRIVE GEAR SHAFT	軸傳驅動軸	1
13	BD7143	FIXED SCREW	傳動軸固定螺絲(長)	1
14	HMY2-10	PIN, d2x10	軸承滾針, d2x10	1

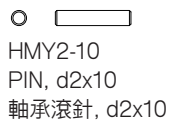

Assemble the Tail Boom Bracket as drawing. Secure the Screws but do not tighten at this step.
參考圖示組裝尾管固定座，螺絲只需稍事固定，暫無需鎖緊。

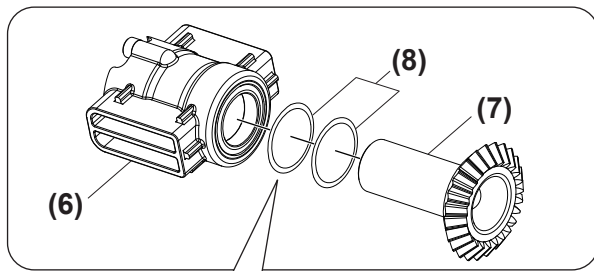
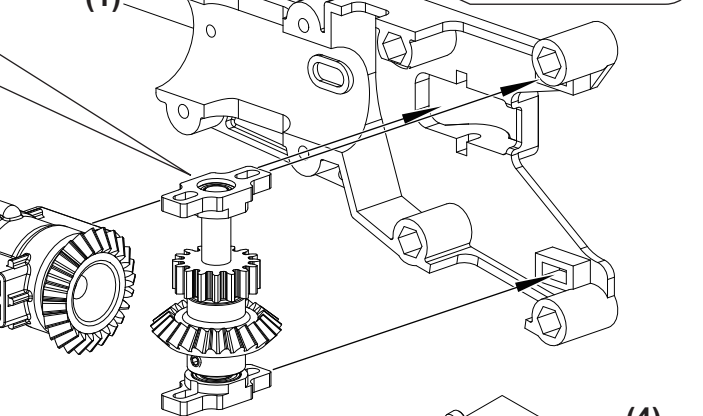
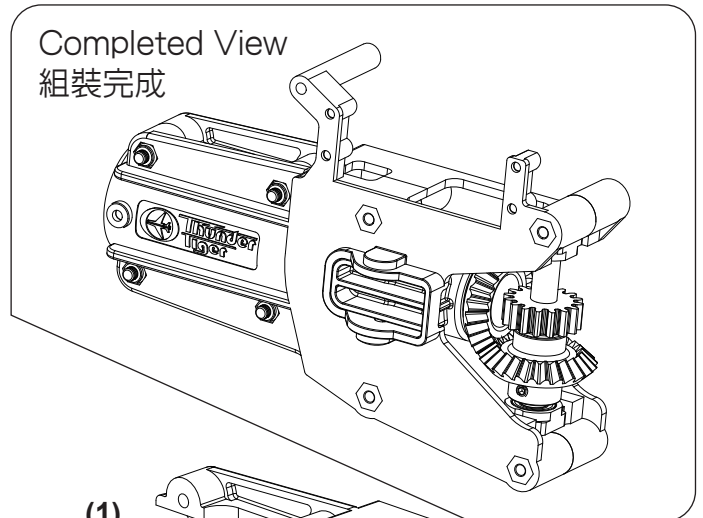
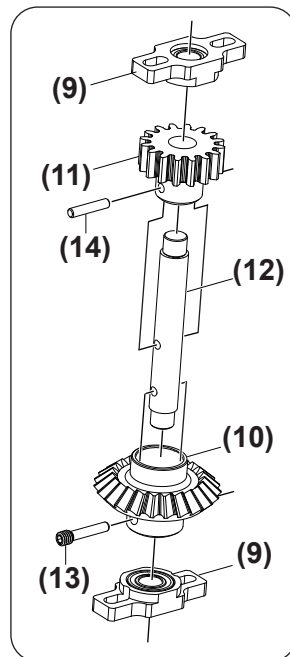

Check the mesh of Gears (#7& #10) after this step accomplished, if the mesh is too much play, please add the Washers to eliminate the play for a proper mesh.
完成尾管固定座組裝步驗後，請檢查齒輪間隙，若間隙過大，請加裝所附墊片進行調整，以獲得適當的齒輪間隙。

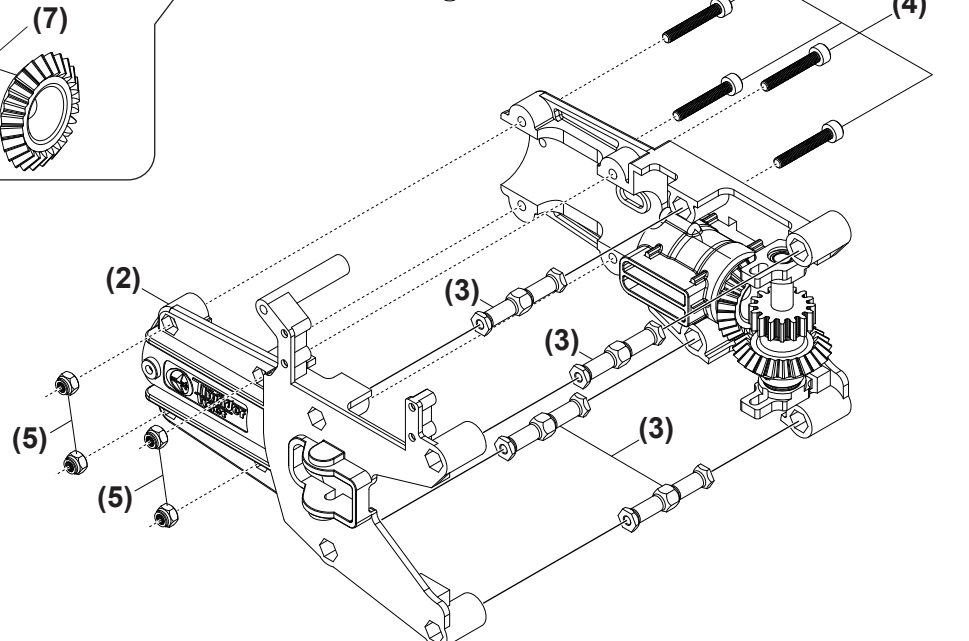

No.	Material No.	Description	名稱	Qty
1	BK2215	SIDE FRAME	機身側板	2
2	HMC2-4B	SOCKET SCREW,M2x4	內六角螺絲,M2x4	4
3	BK2246	TANK RUBBER GROMMETS	油箱保護膠套	2

No.	Material No.	Description	名稱	Qty
4	BK0274	RUBBER GROMMETS	橡膠墊圈	2
5	BV2238	ELEVATOR WASHER MOUNT SET-L	升降舵墊片座組(左)	1
6	BV2237	ELEVATOR WASHER MOUNT SET-R	升降舵墊片座組(右)	1

HMC2-4B
內六角螺絲,M2x4
SOCKET SCREW,M2x4

Left Frame / 左側板

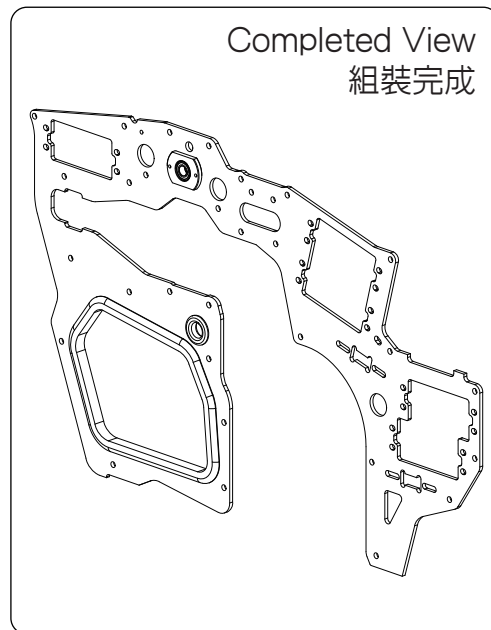
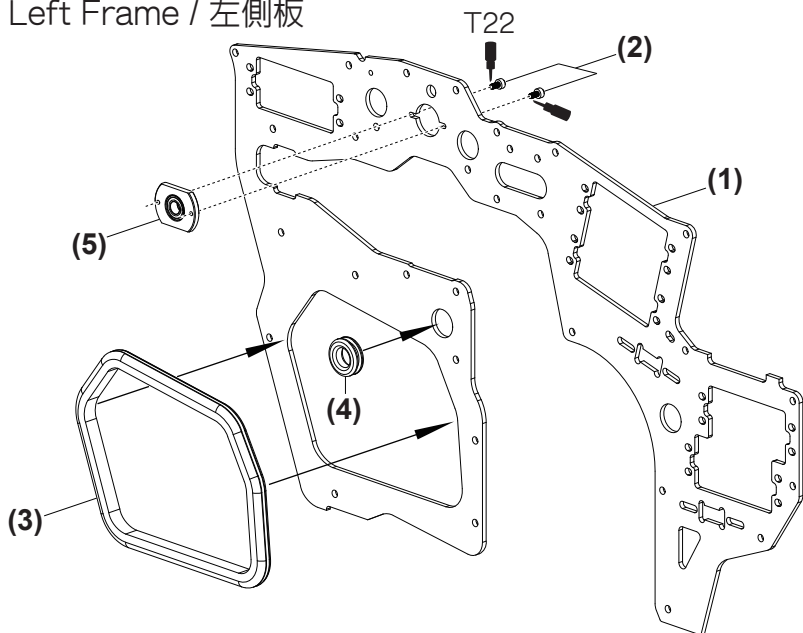

Right Frame / 右側板

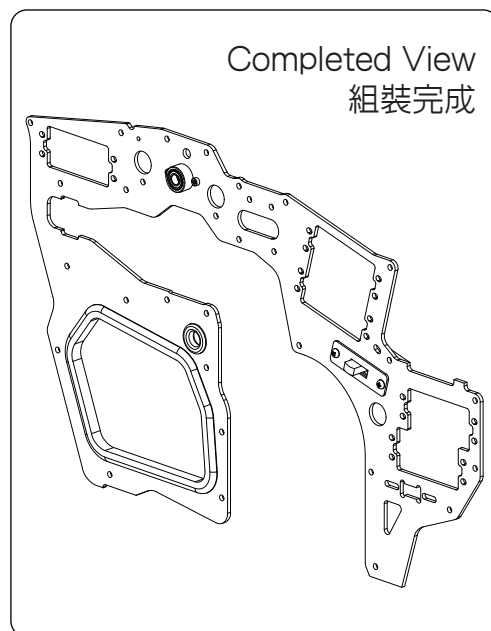
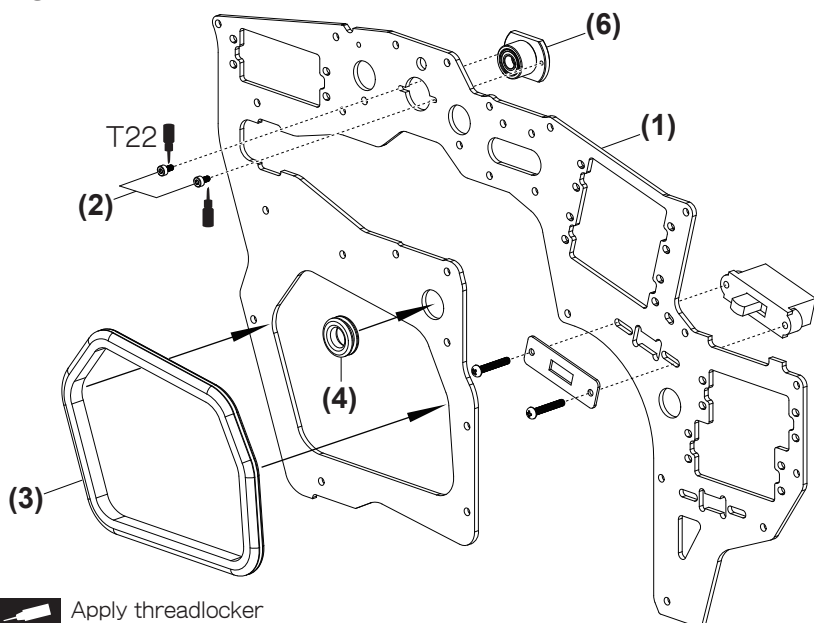

Apply threadlocker
使用螺絲防鬆膠

No.	Material No.	Description	名稱	Qty
1	BK0594	STARTER COUPLING	啟動接頭	1
2	BK2241-L	CLUTCH BEARING BLOCK-L	啟動棒軸承固定座(左)	1
3	BK2241-R	CLUTCH BEARING BLOCK-R	啟動棒軸承固定座(右)	1
4	BK2219	FRAME SPACER	六角連接支柱	7
5	HME4-5B	SET SCREW,M4x5	無頭內六角螺絲,M4x5	2
6	HMV696ZZY	BEARING,d6xD15xW5	滾珠軸承,d6xD15xW5	1
7	HMV1680ZZY	BEARING,d8xD16xW5	滾珠軸承,d8xD16xW5	2
8	BK0779-1	PINION,10T	驅動軸,10T	1
9	BV1194-1	CLUTCH BELL SET	離合器罩組	1

No.	Material No.	Description	名稱	Qty
10	BK0592	STARTER SHAFT	啟動軸	1
11	BK0584	THRUST WASHER	止推墊片	1
12	HMS5	E-CLIP,5mm	E型扣環,5mm	1
13	HMV6800ZZY	BEARING,d10xD19xW5	滾珠軸承,d10xD19xW5	1
14	BK2225	LOWER BRG	下軸承座	1
15	BK2220	COOLING FAN CASING	風扇罩	1
16	BK0087	WASHER,d3xD8xW1.4	墊片,d3xD8xW1.4	8
17	HMC3-10B	SOCKET SCREW,M3x10	內六角螺絲,M3x10	11
18	HNX3-12B	S.B.H SELF TAPPING SCREW	半圓頭內六角自攻螺絲	3
19	BK2229	MOUNTING BLOCK	側板補強肋	1

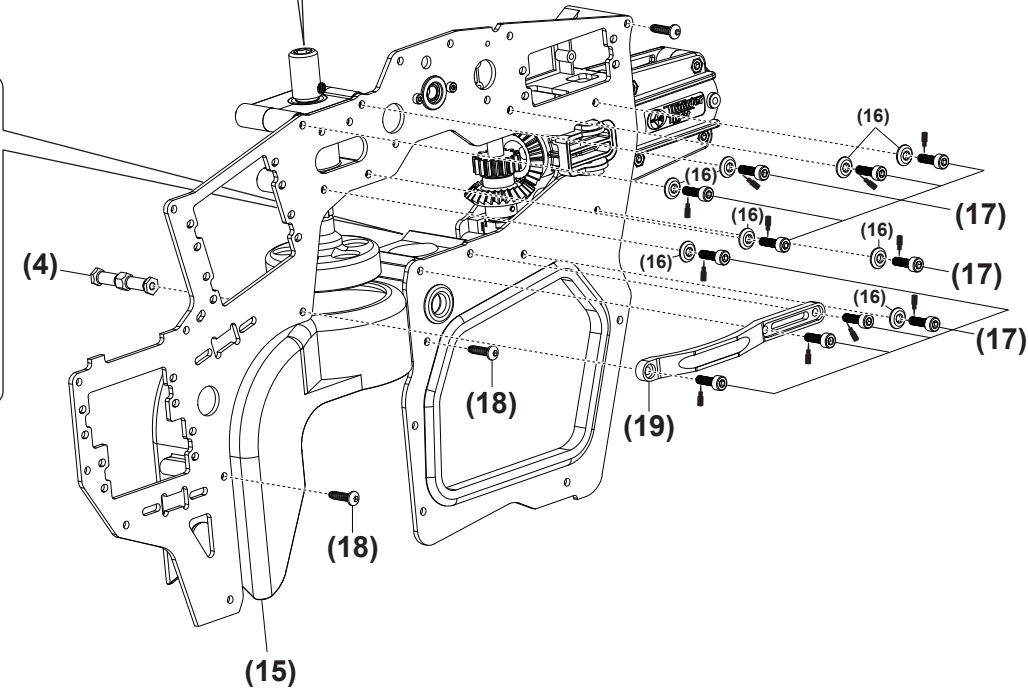
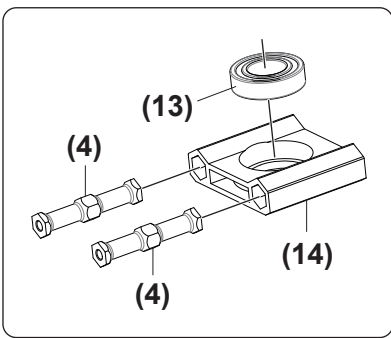
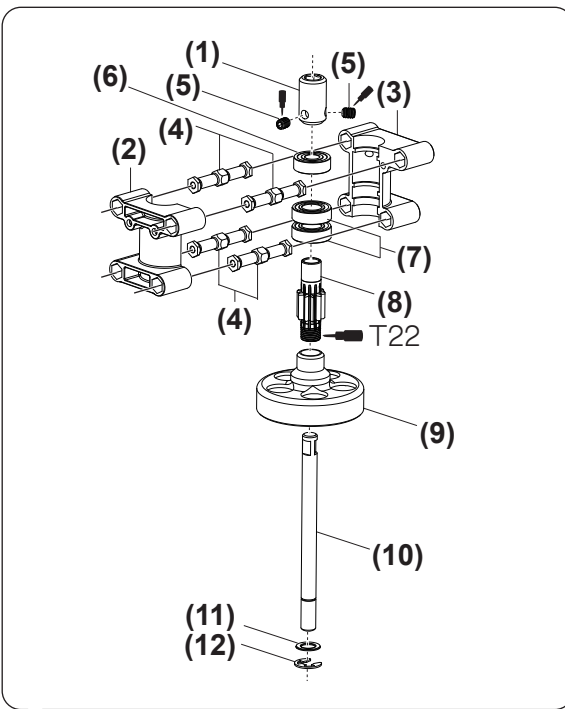

Apply threadlocker
使用螺絲防鬆膠

No.	Material No.	Description	名稱	Qty
1	BK0087	WASHER, d3xD8xW1.4	墊片, d3xD8xW1.4	6
2	HMC3-10B	SOCKET SCREW, M3x10	內六角螺絲, M3x10	9
3	HNX3-12B	S.B.H SELF TAPPING SCREW	半圓頭內六角自攻螺絲	12

No.	Material No.	Description	名稱	Qty
4	BK2229	MOUNTING BLOCK	側板補強肋	1
5	BK2259	SERVO FRAME B	伺服機座B	1
6	BK2232	SERVO FRAME A	伺服機座A	1

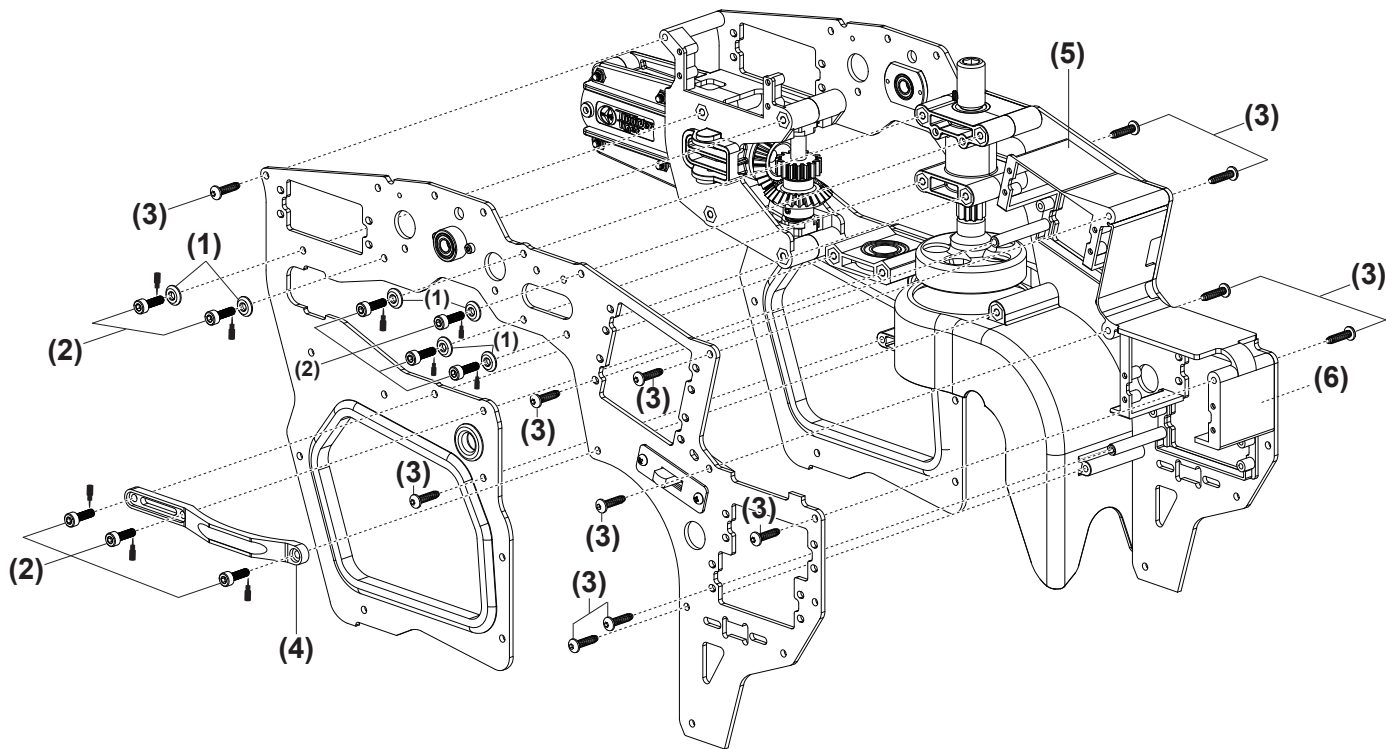
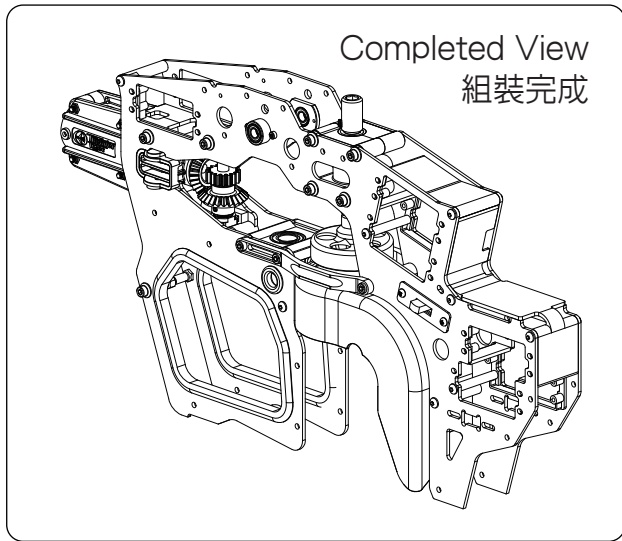

Apply threadlocker
使用螺絲防鬆膠

No.	Material No.	Description	名稱	Qty
1	BV0589	CLUTCH SHOE	離合器組	1
2	BK0170	SHIM	離合器墊片	1
3	BV0143	COOLING FAN	冷卻風扇組	1
4	HMC3-10B	SOCKET SCREW,M3x10	內六角螺絲,M3x10	2
5	HMC3-14B	SOCKET SCREW,M3x14	內六角螺絲,M3x14	4

No.	Material No.	Description	名稱	Qty
6	BK2231	ENGINE MOUNT	引擎固定座	1
7	HMF2-10N	PHILLIPS MACHINE SCREW,M2x10	圓頭十字螺絲(細),M2x10	1
8	BK0075	LINK BALL	連接頭	1
9	HML2	NUT,M2	六角螺帽,M2	1

BK0170
SHIM,d16xW0.15
離合器墊片,d16xW0.15

HMC3-10B
SOCKET SCREW,M3x10
內六角螺絲,M3x10

HMC3-14B
SOCKET SCREW,M3x14
內六角螺絲,M3x14

HMF2-10N
PHILLIPS MACHINE SCREW,M2x10
圓頭十字螺絲(細),M2x10

BK0075
LINK BALL, Ø4.8
連接頭, Ø4.8

HML2
NUT,M2
六角螺帽,M2

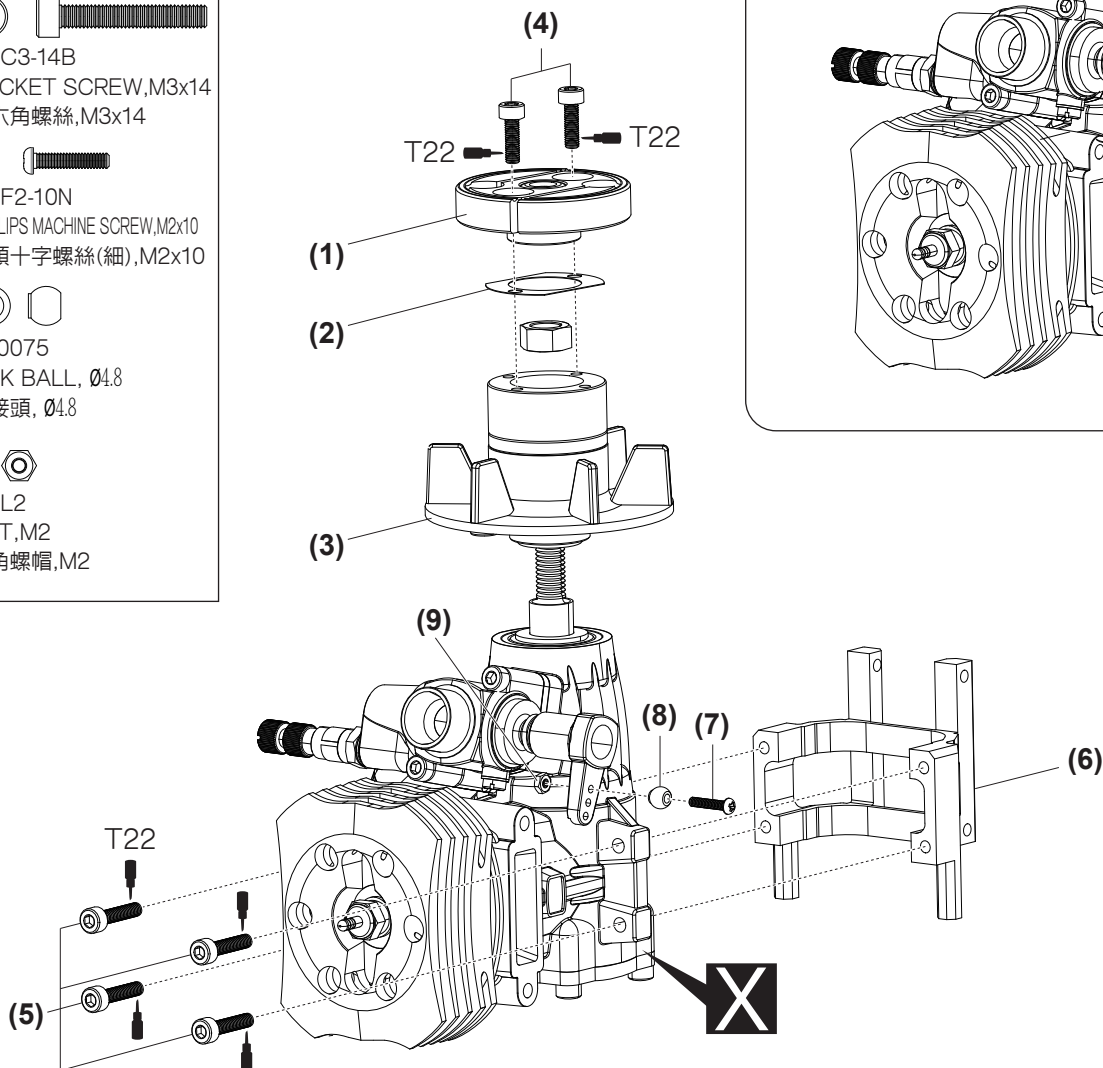
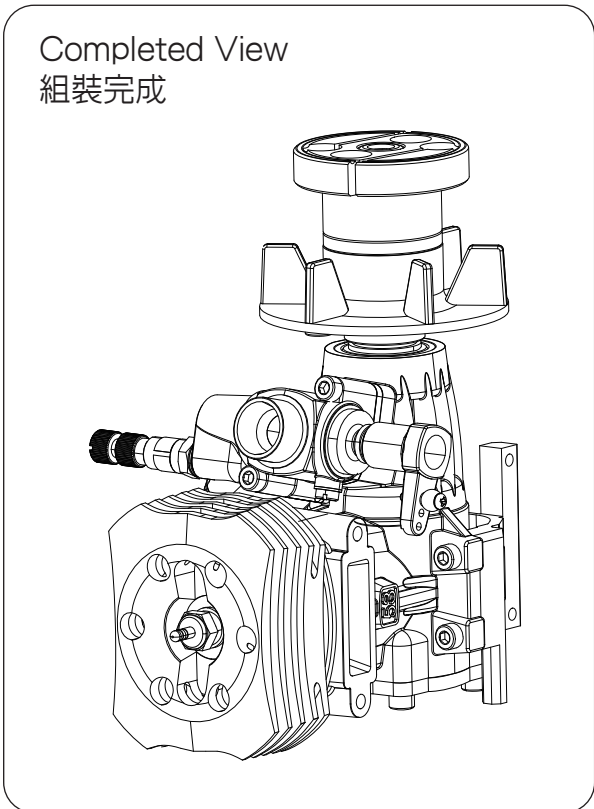

Must be purchased separately
改裝品需另購



Apply threadlocker
使用螺絲防鬆膠

No.	Material No.	Description	名稱	Qty
1	HMC3-10B	SOCKET SCREW,M3x10	內六角螺絲,M3x10	8
2	BK0087	WASHER,d3xD8xW1.4	墊片,d3xD8xW1.4	4
3	BK2240-L	PLATE MOUNTING BLOCK-L	底盤固定座(左)	2
4	BK2240-R	PLATE MOUNTING BLOCK-R	底盤固定座(右)	2

No.	Material No.	Description	名稱	Qty
5	HMM3Z	NYLON NUT,M3	止鬆螺帽,M3	4
6	BK2234	CARBON BOTTOM FRAME	碳纖維底盤	1
7	HMC3-6B	SOCKET SCREW,M3x6	內六角螺絲,M3x6	2

HMC3-10B
SOCKET SCREW,M3x10
內六角螺絲,M3x10

BK0087
WASHER,d3xD8xW1.4
墊片,d3xD8xW1.4

HMM3Z
NYLON NUT,M3
止鬆螺帽,M3

HMC3-6B
SOCKET SCREW,M3x6
內六角螺絲,M3x6

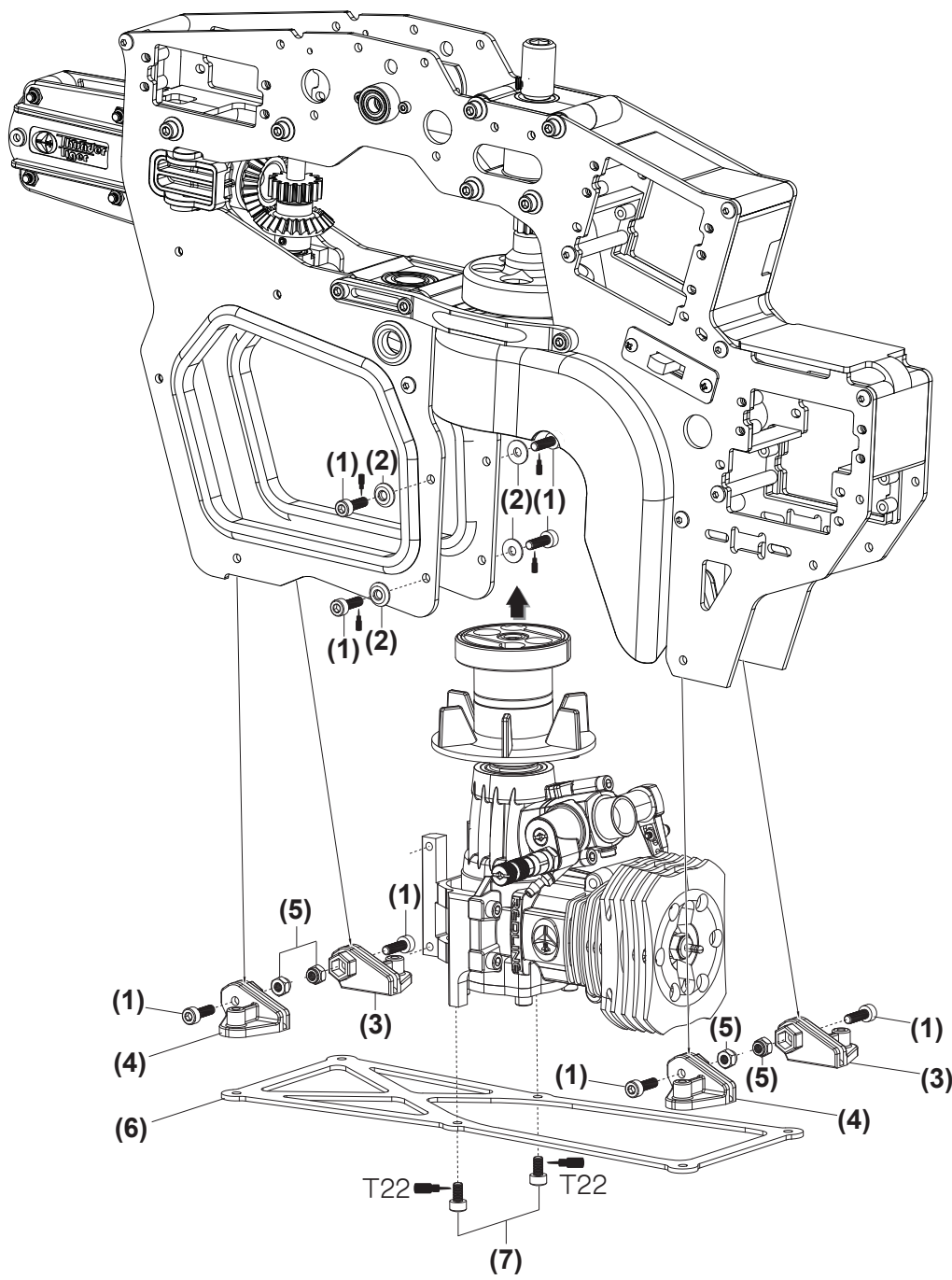

Apply threadlocker
使用螺絲防鬆膠

No.	Material No.	Description	名稱	Qty
1	BK0023	ELEVATOR CONTROL ARM LINK	升降舵連接座	1
2	BK0084	PIN,D2x22.8	固定銷,D2x22.8	1
3	BK2514	METAL ELEVATOR CONTROL ARM	金屬升降舵控制臂	1
4	HME3-3B	SET SCREW,M3x3	無頭內六角螺絲,M3x3	1
5	HME3-8B	SET SCREW,M3x8	無頭內六角螺絲,M3x8	1
6	BK2161	ELEVATOR LEVER ROD	升降舵推拉桿	1
7	BK0649-1	LINKAGE BALL (A)	內六角連接頭螺絲(A)	2

No.	Material No.	Description	名稱	Qty
8	BK2515	COLLAR,d3xD5xW4.2	控制臂軸環,d3xD5xW4.2	1
9	HMC3-10B	SOCKET SCREW,M3x10	內六角螺絲,M3x10	1
10	BK2261	LANDING SKID	腳架	2
11	BK0064T	SKID PIPE	底座圓管	2
12	BK0065	SKID PIPE END CAP	圓管塞	4
13	HME4-5B	SET SCREW,M4x5	無頭內六角螺絲,M4x5	4
14	HMC3-14B	SOCKET SCREW,M3x14	內六角螺絲,M3x14	4



The larger hole goes toward the swashplate.
較大孔面朝十字盤

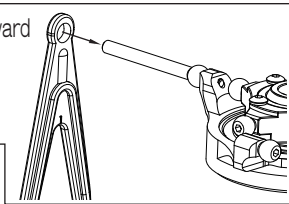

HME3-3B
SET SCREW,M3x3
無頭內六角螺絲,M3x3

HME3-8B
SET SCREW,M3x8
無頭內六角螺絲,M3x8

BK0649-1
LINKAGE BALL (A)
內六角連接頭螺絲(A)

BK2515
COLLAR,d3xD5xW4.2
控制臂軸環,d3xD5xW4.2

HMC3-10B
SOCKET SCREW,M3x10
內六角螺絲,M3x10

HME4-5B
SET SCREW,M4x5
無頭內六角螺絲,M4x5

HMC3-14B
SOCKET SCREW,M3x14
內六角螺絲,M3x14

BK0084
PIN,D2x22.8
固定銷,D2x22.8

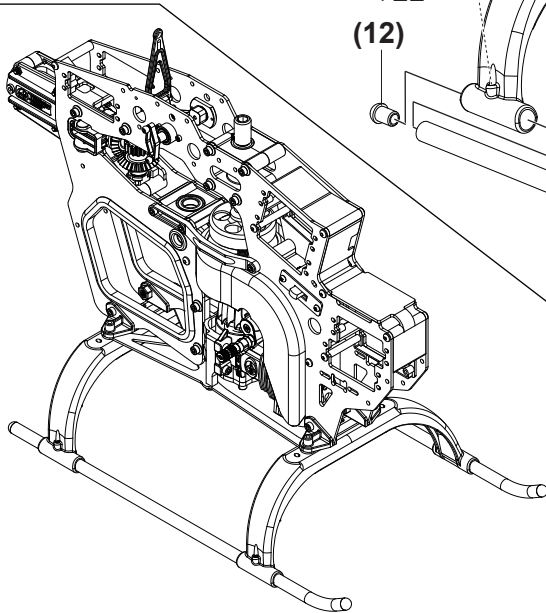
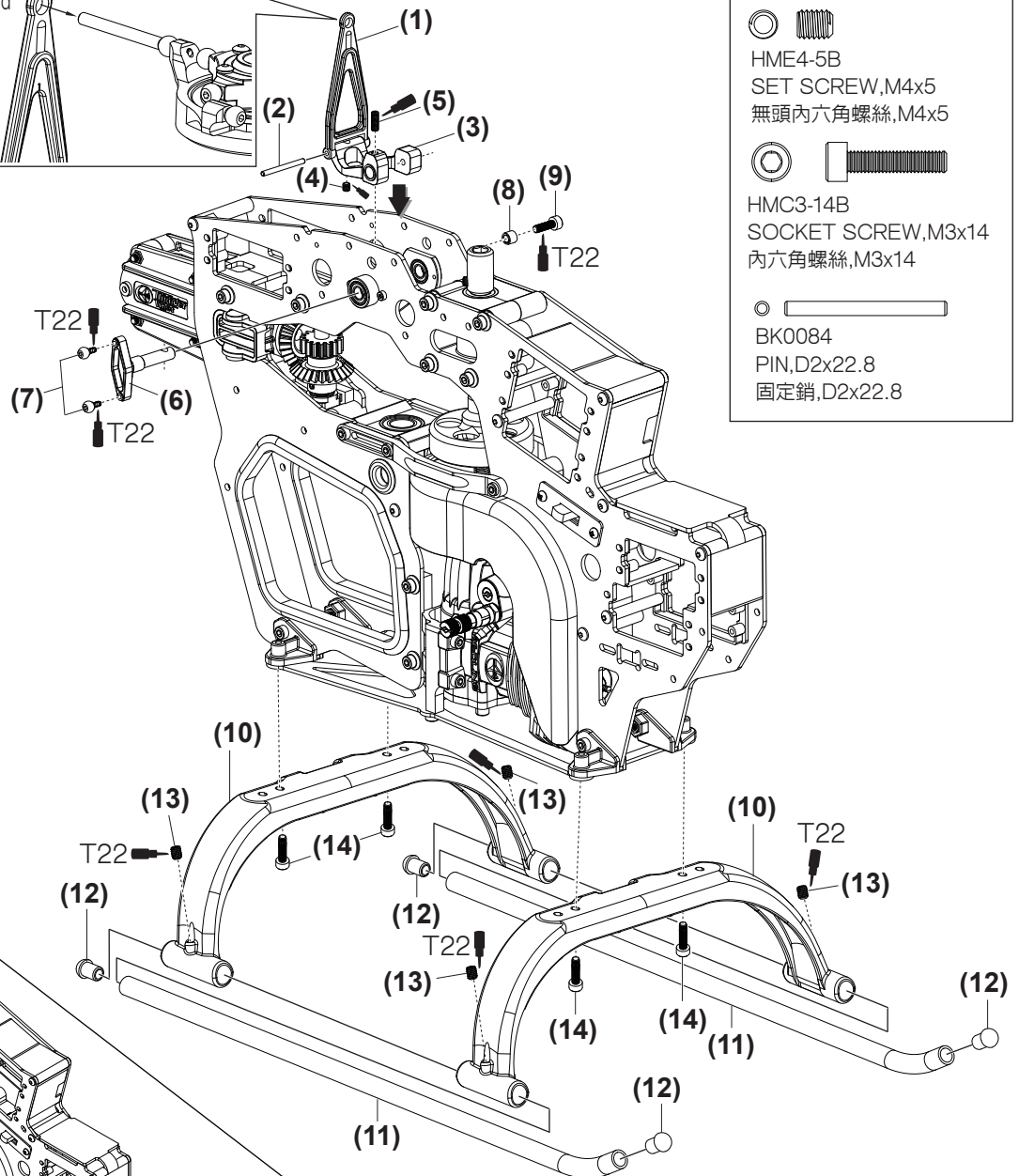

Completed View
組裝完成



Apply threadlocker
使用螺絲防鬆膠

No.	Material No.	Description	名稱	Qty
1	BK2282	ONE WAY BEARING SHAFT	單向軸套	1
2	BV2281	ONE WAY CLUTCH HOUSING	單向離合組	1
3	BK2285	MAIN GEAR,85T	主齒輪,85T	1

No.	Material No.	Description	名稱	Qty
4	HSA3-8	BUTTON HEAD SOCKET SCREW,M3x8	半圓頭內六角螺絲,M3x8	4
5	BK2524	MAIN GEAR WASHER	主齒輪墊片	1
6	BK2287	AUTOROTATION TAIL DRIVE PULLEY,80T	軸傳尾驅動主齒,80T	1



HSA3-8
BUTTON HEAD SOCKET SCREW,M3x8
半圓頭內六角螺絲,M3x8



BK2524
MAIN GEAR WASHER,d14.2xD19xW0.5
主齒輪墊片,d14.2xD19xW0.5

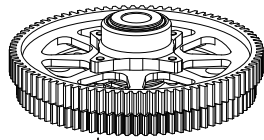
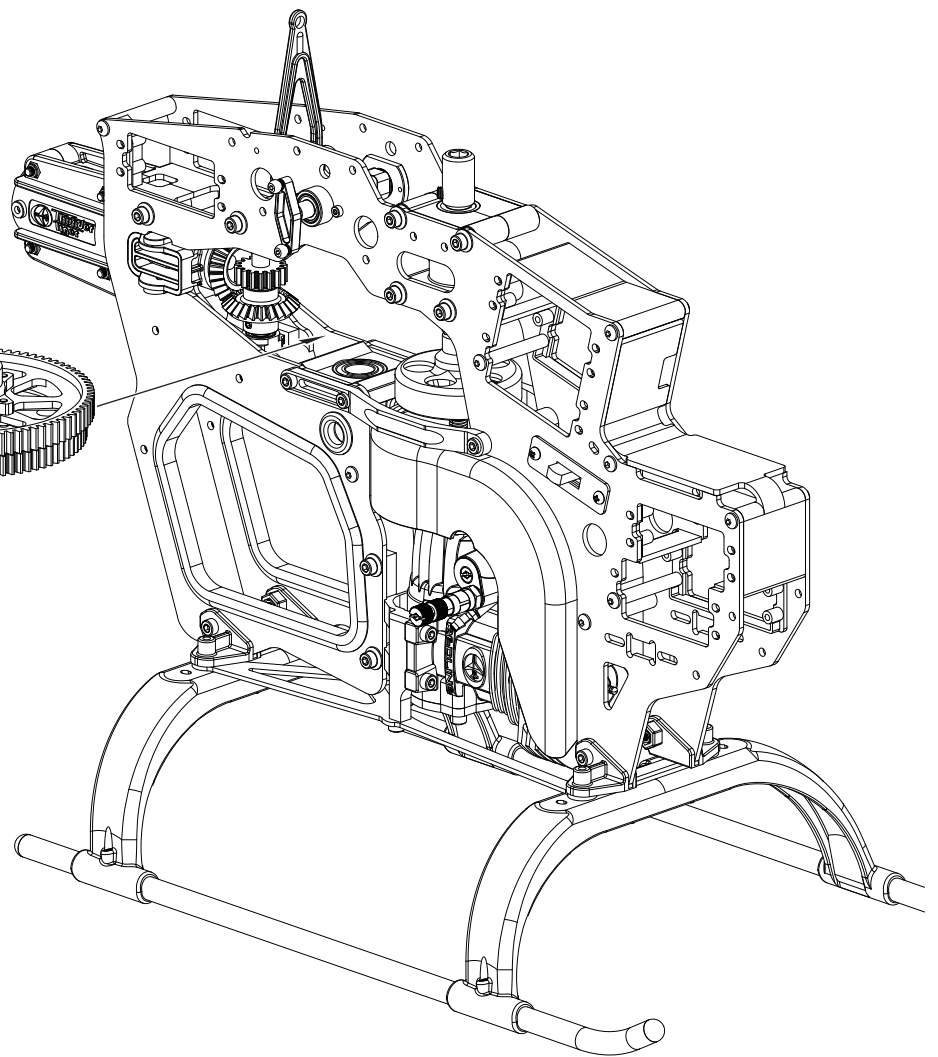

Note the chamfer should point up.
注意有倒角端朝上

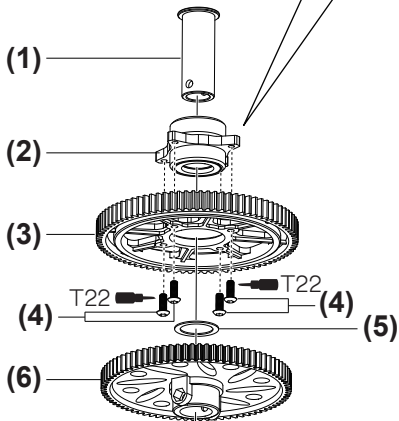
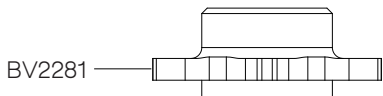

Apply threadlocker
使用螺絲防鬆膠

No.	Material No.	Description	名稱	Qty
1	HMC3-10B	SOCKET SCREW,M3x10	內六角螺絲,M3x10	4
2	BK0087	WASHER,d3xD8xW1.4	墊片,d3xD8xW1.4	4
3	BK1197	MAIN SHAFT BOLT,M3x20	內六角半牙螺絲,M3x20	1
4	BK2290	COLLAR	軸環	1
5	HMM3Z	NYLON NUT,M3	止鬆螺帽,M3	1

HMC3-10B
SOCKET SCREW,M3x10
內六角螺絲,M3x10

BK0087
WASHER,d3xD8xW1.4
墊片,d3xD8xW1.4

BK1197
MAIN SHAFT BOLT,M3x20
內六角半牙螺絲,M3x20

BK2290
COLLAR,d10xD14xW9
軸環,d10xD14xW9

HMM3Z
NYLON NUT,M3
止鬆螺帽,M3

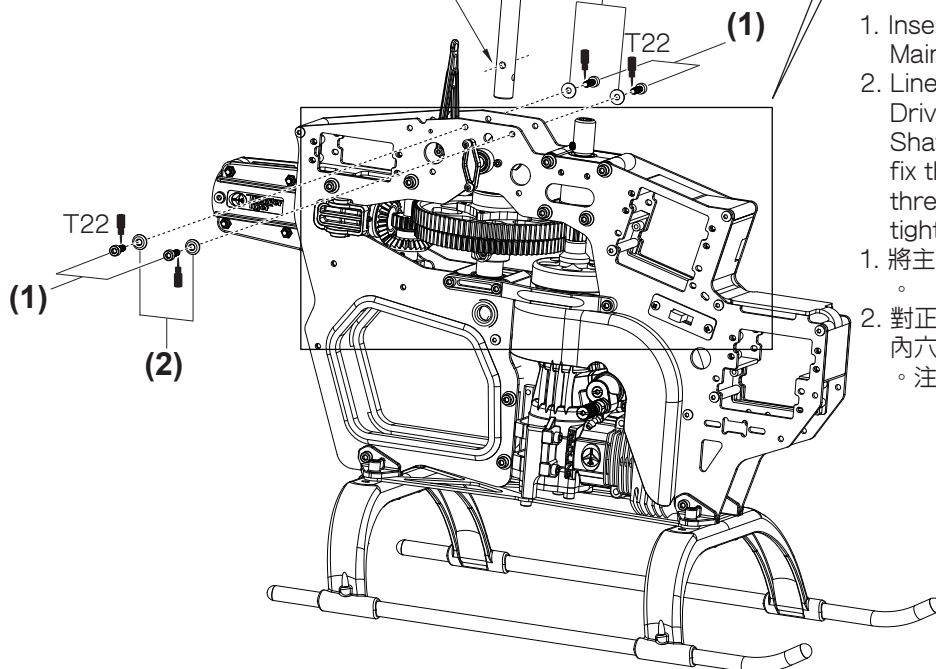
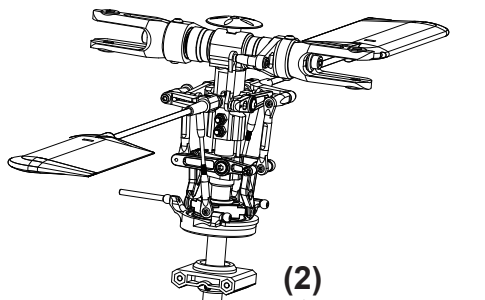
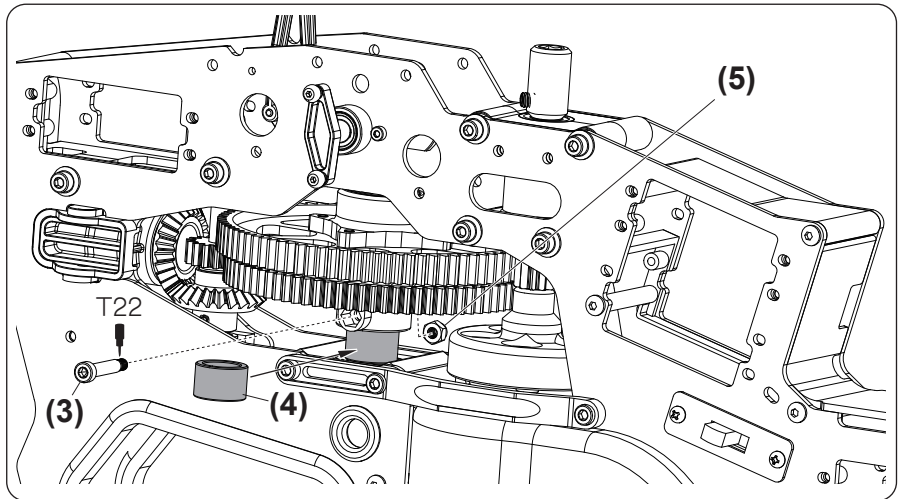

1. Insert the Main Shaft into Main Gear Set, Main Gear Washer & Lower Bearing Block.
 2. Line up the holes of the Autorotation Tail Drive Gear, One Way Bearing Shaft & Main Shaft, and then insert the Socket Screw to fix them with a Nut. Add a drop of threadlocker when securing, but do not over tighten.
1. 將主軸依序穿過主齒輪組、主齒輪墊片及下軸承座。
 2. 對正尾驅動齒、單向軸套及主軸上孔位後，穿入內六角螺絲並加上螺帽，並使用適量防鬆劑固定。注意！請勿過度緊迫螺絲。



Apply threadlocker
使用螺絲防鬆膠

No.	Material No.	Description	名稱	Qty
1	BK2230	FUEL TANK	油箱	1
2	BE1867	CLUNK	油箱重錘	1
3	BB0363-60	FUEL TUBE,D3.5mm x 60mm	耐熱油管,D3.5mm x 60mm	1
4	BK0062	FUEL TANK GROMMET	油嘴栓	1
5	BK0463	FUEL TANK NIPPLE	油嘴	1
6	BK2248	PHASING CONTROL TRACK	相位控制導軌	1
7	BK2249	CANOPY RETAINING POST	機殼固定鋁柱	2
8	HME3-18B	SET SCREW,M3x18	無頭內六角螺絲,M3x18	2
9	HMC2-4B	SOCKET SRCEW,M2x4	內六角螺絲,M2x4	2
10	HNX3-12B	S.B.H SELF TAPPING SCREW	半圓頭內六角自攻螺絲	5

No.	Material No.	Description	名稱	Qty
11	BK2257	LONGER RECEIVER FRAME	加長型接收機座	1
12	BK0473-1	CANOPY SPACER	機殼支撐柱	1
13	BK0474	GROMMET	橡膠帽	2
14	HNLR6	R CLIP	R形插銷	2
15	BK2247	ROD GUIDE MOUNTING BLOCK	尾拉桿座	1
16	HMC3-10B	SOCKET SCREW,M3x10	內六角螺絲,M3x10	1
17	HMC3-14B	SOCKET SCREW,M3x14	內六角螺絲,M3x14	1
18	BK0087	WASHER,d3xD8xW1.4	墊片,d3xD8xW1.4	1
19	BK0506	TANK MOUNT	副油箱固定座	1
20	BV0502	HEADER TANK	副油箱組	1

HME3-18B
 SET SCREW,M3x18
 無頭內六角螺絲,M3x18

HMC2-4B
 SOCKET SRCEW,M2x4
 內六角螺絲,M2x4

HNX3-12B
 S.B.H SELF TAPPING SCREW
 半圓頭內六角自攻螺絲

HMC3-10B
 SOCKET SCREW,M3x10
 內六角螺絲,M3x10

HMC3-14B
 SOCKET SCREW,M3x14
 內六角螺絲,M3x14

BK0087
 WASHER,d3xD8xW1.4
 墊片,d3xD8xW1.4

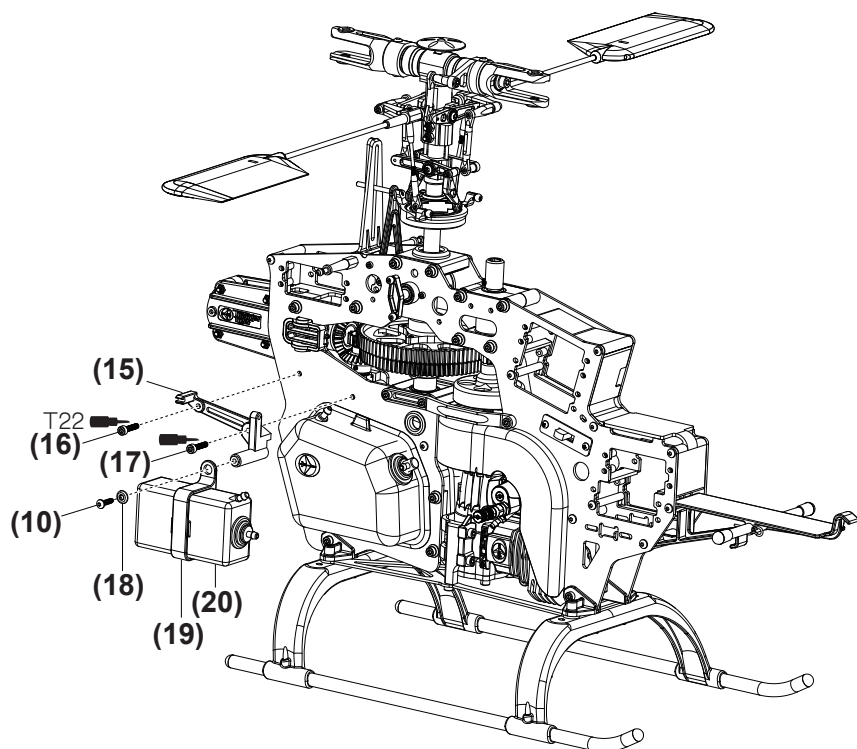
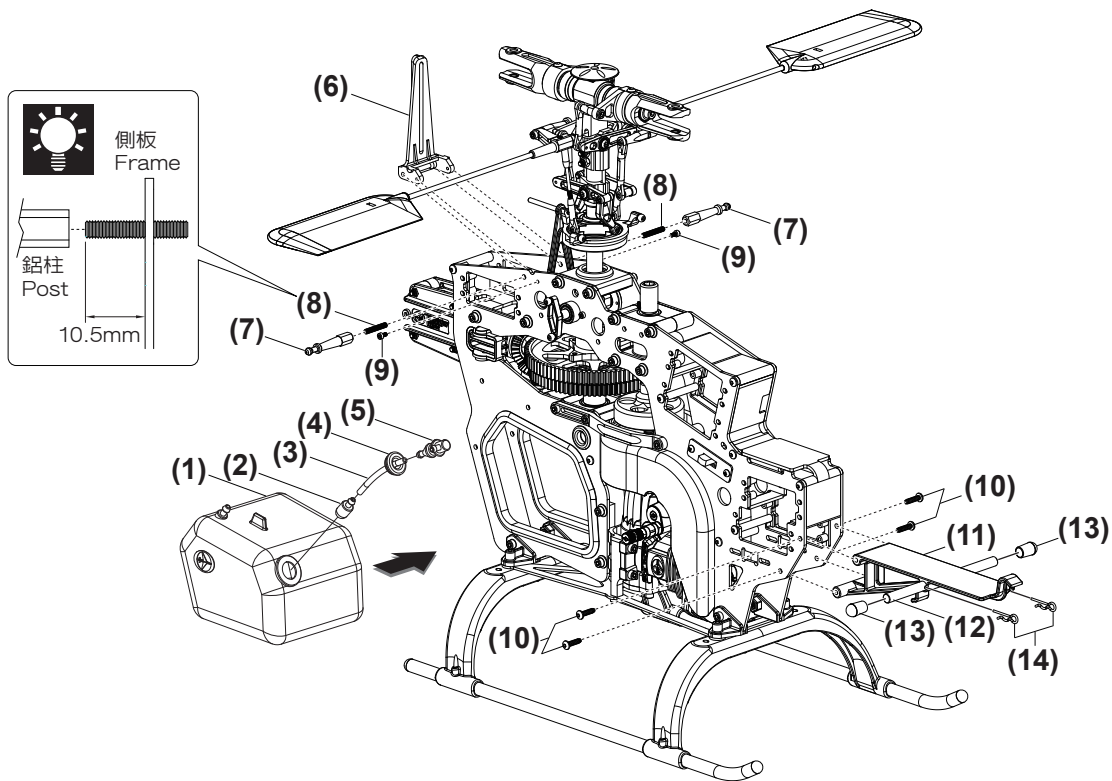

Apply threadlocker
 使用螺絲防鬆膠

No.	Material No.	Description	名稱	Qty
1	HMM3Z	NYLON NUT, M3	止鬆螺帽, M3	2
2	BK0077	COLLAR, d3xD4xW6	軸環, d3xD4xW6	2
3	HMV740ZZY	BEARING, d4xD7xW2.5	滾珠軸承, d4xD7xW2.5	4
4	BK0649-2	LINKAGE BALL (B)	內六角連接頭自攻螺絲(B)	6
5	BK2160-R	120° CONTROL ARM-R	120° 控制搖臂(右)	1
6	BK2160-L	120° CONTROL ARM-L	120° 控制搖臂(左)	1
7	BK2227	ARM COLLAR	擺臂固定軸環	2

No.	Material No.	Description	名稱	Qty
8	HME3-30B	SET SCREW, M3x30	無頭內六角螺絲, M3x30	2
9	BK2529	TAIL DRIVE SHAFT BRG	傳動軸軸承套	1
10	HMV1680ZZY	BEARING, d8xD16xW5	滾珠軸承, d8xD16xW5	1
11	BK2552	TAIL DRIVE SHAFT	尾驅動軸	1
12	HMC2512B	SOCKET SCREW, M2.5x12	內六角螺絲, M2.5x12	2
13	HMM25Z	NYLON NUT, M2.5	止鬆螺帽, M2.5	2
14	BK0367	TAIL DRIVE SHAFT LINKER	尾驅動連接棒	2

HMM3Z
NYLON NUT, M3
止鬆螺帽, M3

BK0077
COLLAR, d3xD4xW6
軸環, d3xD4xW6

HMV740ZZY
BEARING, d4xD7xW2.5
滾珠軸承, d4xD7xW2.5

BK0649-2
LINKAGE BALL (B)
內六角連接頭自攻螺絲(B)

HME3-30B
SET SCREW, M3x30
無頭內六角螺絲, M3x30

HMC2512B
SOCKET SCREW, M2.5x12
內六角螺絲, M2.5x12

HMV1680ZZY
BEARING, d8xD16xW5
滾珠軸承, d8xD16xW5

Step 1 / 步驟一

Attach the Control Arms onto the Main Frame Set as drawing, and note the difference of Left & Right Control Arms, please refer the "120L" / "120R" mark on the arms.
參考圖示將控制搖臂裝上主側板上，請注意左、右邊的控制搖臂不同，請對照控制搖臂上L或R凸字安裝。

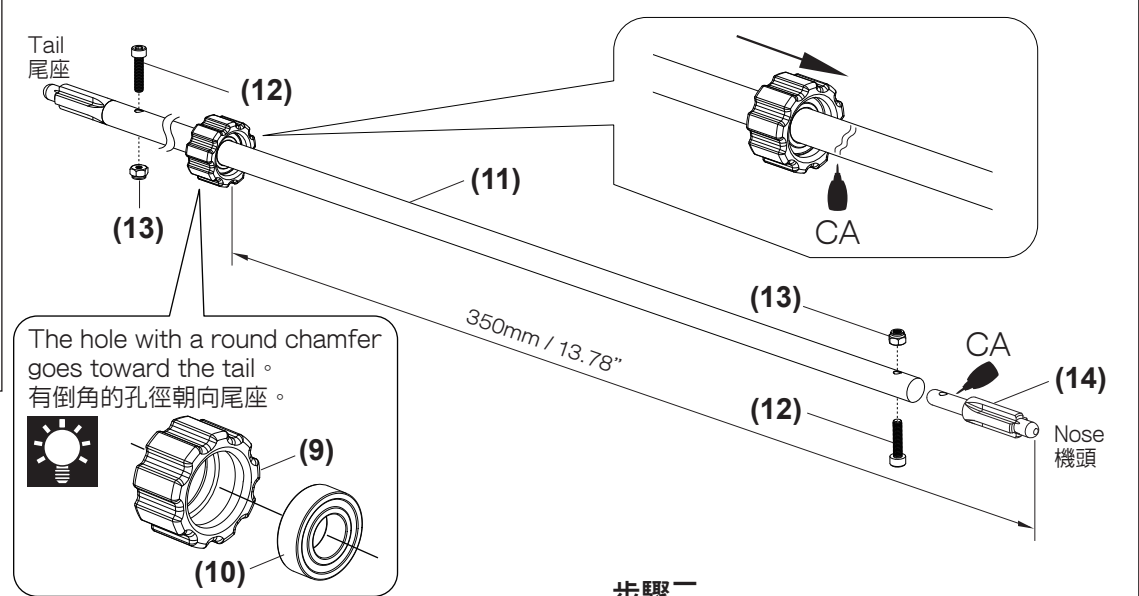
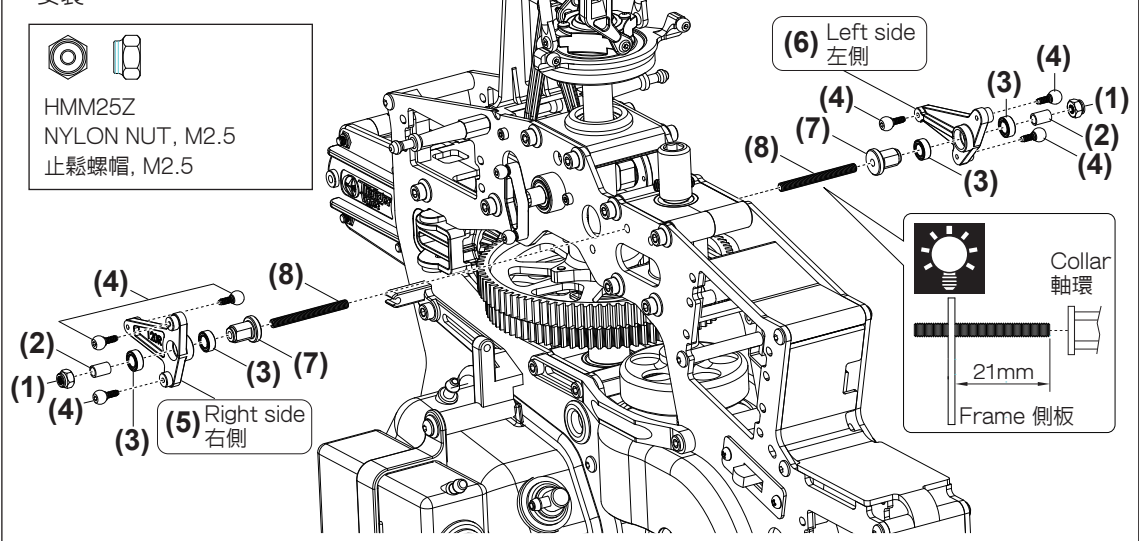

Step 2

1. Attach the Bearing into the Rubber Bearing Support.
2. Screw the Shaft End onto the Tail Drive Shaft with a drop of threadlocker as the drawing, but do not over tighten.
3. Add a drop of thin CA glue on the Tail Drive Shaft next to where the bearing should be, and then slide the bearings over the position quickly; the distance from the Shaft Drive End to the Rubber Shaft Bearing Support is approx. 350mm / 13.78" .
4. Apply some amount of silicon oil or Vaseline onto the rubber surface for easy install into the tail boom later.

步驟二

1. 將軸承擠壓入橡膠軸套內。
2. 參考圖示，塗抹些許防鬆膠將尾傳動軸接頭鎖在尾傳動軸，但勿過度鎖緊。
3. 在尾傳動軸上軸承固定位置前方，塗抹少量快乾膠，迅速滑動軸承至定位固定；該定位大約距離軸傳動接頭350mm / 13.78" 處。
4. 塗抹些許矽膠油脂或凡士林於橡膠軸套表面上，稍後將尾驅動軸組裝入尾管時，會較為容易。

No.	Material No.	Description	名稱	Qty
1	BK0028	TAIL PITCH CONTROL SLIDER BUSHING	尾旋翼控制軸套	1
2	HMV1060ZZY	BEARING, d6xD10xW3	滾珠軸承, d6xD10xW3	2
3	BK0027	TAIL PITCH CONTROL SLIDER	尾旋翼控制滑座	1
4	BK0025	TAIL PITCH CONTROL FORK	尾旋翼控制座	1
5	HMF2-8N	PHILLIPS MACHINE SCREW, M2x8	圓頭十字螺絲(細), M2x8	1
6	BK0075	LINK BALL, Ø4.8	連接頭, Ø4.8	1
7	BK2280	TAIL ROTOR SHAFT	尾旋翼橫軸(軸傳)	1
8	HME3-3B	SET SCREW, M3x3	無頭內六角螺絲, M3x3	2
9	BK2284	TAIL ROTOR HUB	尾旋翼T型座	1
10	BK2580	METAL TAIL GRIP	金屬尾旋翼座	2

No.	Material No.	Description	名稱	Qty
11	HMV1050ZZWY	BEARING, d5xD10xW3	滾珠軸承, d5xD10xW3	2
12	BK0082	COLLAR, d2xD3xW4.2	軸環, d2xD3xW4.2	2
13	HMC2-10B	SOCKET SCREW, M2×10	內六角螺絲, M2×10	2
14	BK0083	PIN, D2x8.8	固定銷, D2x8.8	2
15	BK0026	TAIL PITCH CONTROL LINK	尾旋翼連接頭	2
16	HMC25-6B	SOCKET SCREW, M2.5x6	內六角螺絲, M2.5x6	2
17	HMO26	WASHER, d2.8xD5xW0.5	墊片, d2.8xD5xW0.5	4
18	BK2276	WASHER, d4xD6xW0.5	尾旋翼轉座墊片, d4xD6xW0.5	2
19	HMV940ZZY	BEARING, d4xD9xW4	滾珠軸承, d4xD9xW4	2
20	HMX0409Y	THRUST BEARING, d4xD9xW4	止推軸承, d4xD9xW4	2



HMF2-8N
PHILLIPS MACHINE SCREW, M2x8
圓頭十字螺絲(細), M2x8

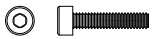

HMC2-10B
SOCKET SCREW, M2×10
內六角螺絲, M2×10



HMC25-6B
SOCKET SCREW, M2.5×6
內六角螺絲, M2.5×6



HME3-3B
SET SCREW, M3x3
無頭內六角螺絲, M3x3



BK0083
PIN, D2x8.8
固定銷, D2x8.8



HMO26
WASHER, d2.8xD5xW0.5
墊片, d2.8xD5xW0.5



BK0082
COLLAR, d2xD3xW4.2
軸環, d2xD3xW4.2



BK2276
WASHER, d4xD6xW0.5
尾旋翼轉座墊片, d4xD6xW0.5



HMV1060ZZY
BEARING, d6xD10xW3
滾珠軸承, d6xD10xW3



HMV1050ZZWY
BEARING, d5xD10xW3
滾珠軸承, d5xD10xW3



HMV940ZZY
BEARING, d4xD9xW4
滾珠軸承, d4xD9xW4

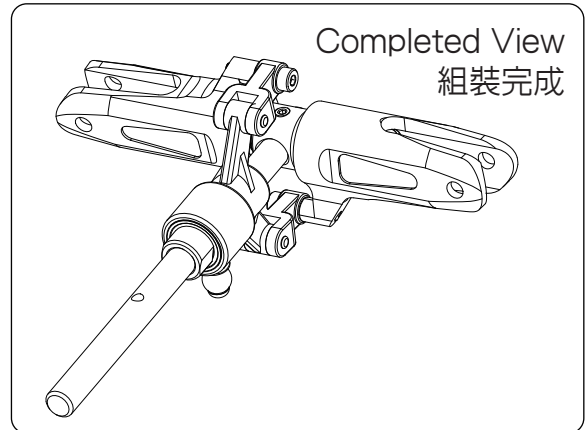

- Note the orientation of the Thrust Bearings; please refer page 9, Diagram for Thrust Bearing Assembly.
- Line up the concave of Tail Rotor Shaft and the hole of Hub when securing the Tail Rotor Hub onto the Tail Rotor Shaft.
- Assemble the tail unit as drawing. Secure the screws with a drop of threadlocking but not over tighten, ensure the moveable parts run effortlessly.
 - 請參考第 9 頁止推軸承安裝示意圖，注意安裝方向性。
 - 將尾旋翼固定座鎖上尾旋翼主軸時，請注意軸上凹槽需對正固定座上螺絲孔。
 - 依圖示順序組裝。使用適量防鬆劑固定，但請勿過度鎖緊，確保每個可動機構皆作動順暢。

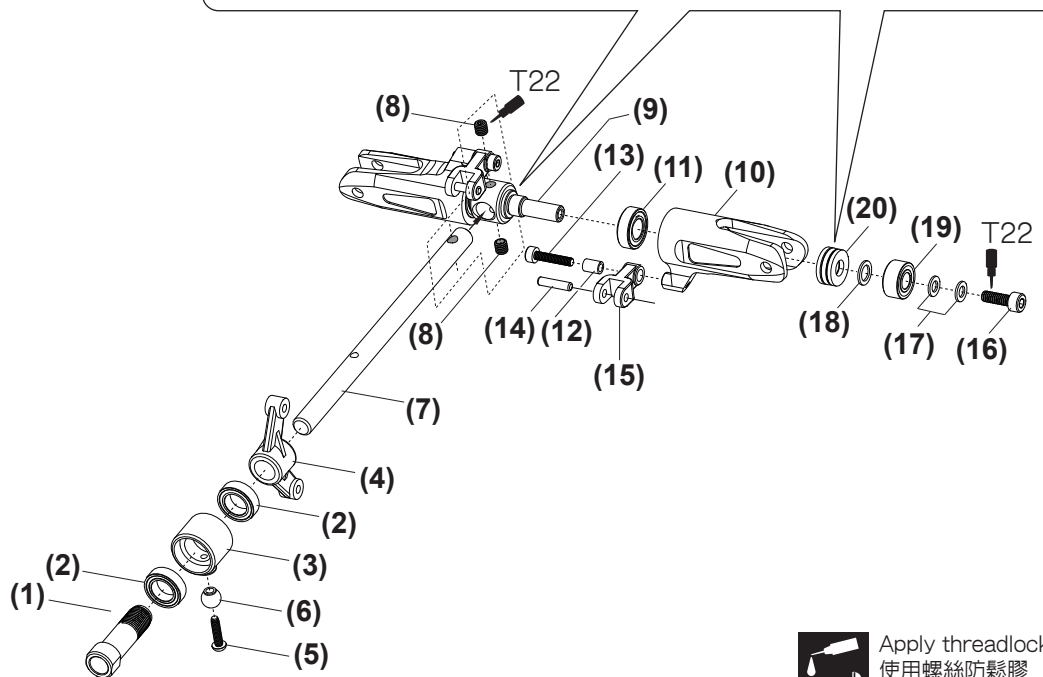

Apply threadlocker
使用螺絲防鬆膠

No.	Material No.	Description	名稱	Qty
1	BK2501	METAL TAIL UNIT HOUSING	金屬尾座	1
2	BK2502	METAL TAIL PITCH CONTROL HOUSING	尾旋翼控制桿座	1
3	HMC25-8B	SOCKET SCREW, M2.5x8	內六角螺絲, M2.5x8	1
4	HMV1350ZZY	BEARING, d5xD13xW4	滾珠軸承, d5xD13xW4	2
5	HMV6701ZZY	BEARING, d12xD18xW4	滾珠軸承, d12xD18xW4	2
6	BK2291	COLLAR, d15xD18x6.8L	軸環, d15xD18x6.8L	1
7	BK0372	TAIL INPUT GEAR	尾齒輪/INPUT-20T	1
8	BK0373-2	TAIL OUTPUT GEAR	尾齒輪/OUTPUT-20T	1
9	BA1144-1	WASHER, d5xD8xW0.15	軸承墊片, d5xD8xW0.15	1
10	HMY2-10	PIN, D2x10	固定銷, D2x10	1
11	BK2512	TAIL PITCH CONTROL LEVER	尾旋翼控制桿	1
12	HMV740ZZY	BEARING, d4xD7xW2.5	滾珠軸承, d4xD7xW2.5	2
13	BK0649-2	LINKAGE BALL (B)	內六角連接頭自攻螺絲(B)	1
14	BK0077	COLLAR, d3xD4xW6	軸環, d3xD4xW6	1

No.	Material No.	Description	名稱	Qty
15	HMC3-10B	SOCKET SCREW, M3x10	內六角螺絲, M3x10	2
16	BK2190	CARBON VERTICAL FIN	碳纖維垂直尾翼	1
17	HMC3-6B	SOCKET SCREW, M3x6	內六角螺絲, M3x6	1
18	BK2503	TAIL ROTOR CASE BUTTON	尾管固定片	1
19	HMC2-5B	SOCKET SCREW, M2x5	內六角螺絲, M2x5	1
20	BK2556	CARBON TAIL BOOM	碳纖維尾管	1
21	BK2559	ROD GUIDE	固定環	3
22	HNN2-6B	TAPPING SCREW, M2x6	墊圈自攻螺絲, M2x6	3
23	HMC3-16B	SOCKET SCREW, M3x16	內六角螺絲, M3x16	2
24	HMM3Z	NYLON NUT (M3)	止鬆螺帽(M3)	2
25	BK0404-B	TAIL BLADE (BLACK)	尾旋翼(黑)	2
26	BK2527	TAIL UNIT LINING	尾座內襯	1
27	HME3-4B	SET SCREW M3x4	無頭內六角螺絲, M3x4	1

HMC25-8B
SOCKET SCREW, M2.5x8
內六角螺, M2.5x8

HMC1350ZZY
BEARING, d5xD13xW4
滾珠軸承, d5xD13xW4

HMV6701ZZY
BEARING, d12xD18xW4
滾珠軸承, d12xD18xW4

BK2291
COLLAR, d15xD18x6.8L
軸環, d15xD18x6.8L

BA1144-1
WASHER, d5xD8xW0.15
軸承墊片, d5xD8xW0.15

HMY2-10
PIN, D2x10
固定銷, D2x10

HMV740ZZY
BEARING, d4xD7xW2.5
滾珠軸承, d4xD7xW2.5

BK0649-2
LINKAGE BALL (B)
內六角連接頭自攻螺絲(B)

BK0077
COLLAR, d3xD4xW6
軸環, d3xD4xW6

HMC3-10B
SOCKET SCREW, M3x10
內六角螺絲, M3x10

BK2190
CARBON VERTICAL FIN
碳纖維垂直尾翼

HMC3-6B
SOCKET SCREW, M3x6
內六角螺絲, M3x6

BK2503
TAIL ROTOR CASE BUTTON
尾管固定片

HMC2-5B
SOCKET SCREW, M2x5
內六角螺絲, M2x5

BK2556
CARBON TAIL BOOM
碳纖維尾管

BK2559
ROD GUIDE
固定環

HNN2-6B
TAPPING SCREW (W/WASHER) M2x6
圓頭墊圈自攻螺絲 M2x6

HMC3-16B
SOCKET SCREW, M3x16
內六角螺絲, M3x16

HMM3Z
NYLON NUT (M3)
止鬆螺帽(M3)

BK0404-B
TAIL BLADE (BLACK)
尾旋翼(黑)

BK2527
TAIL UNIT LINING
尾座內襯

HME3-4B
SET SCREW M3x4
無頭內六角螺絲, M3x4

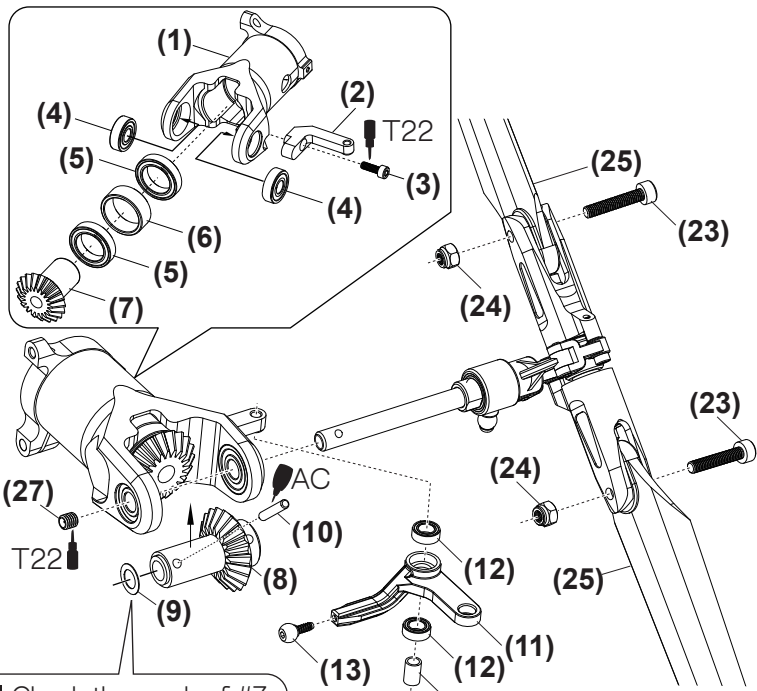

Check the mesh of #7 & #8, please add the Washers (#9) for a proper mesh if too much play.
請檢查#7及#8的齒輪間隙, 間隙過大時請酌加墊片(#9)。

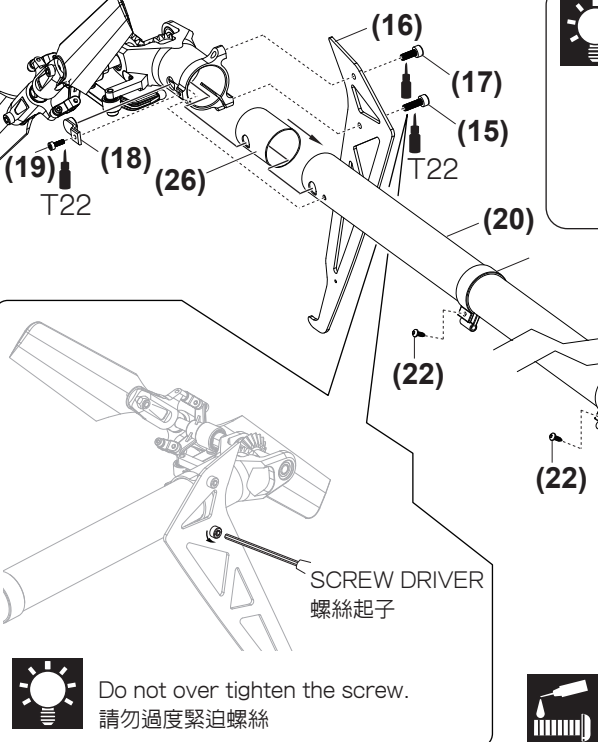

Do not over tighten the screw.
請勿過度緊迫螺絲

Apply threadlocker
使用螺絲防鬆膠

HMC3-6B
SOCKET SCREW, M3x6
內六角螺絲, M3x6

HMC2-5B
SOCKET SCREW, M2x5
內六角螺絲, M2x5

HNN2-6B
TAPPING SCREW (W/WASHER) M2x6
圓頭墊圈自攻螺絲 M2x6

HMC3-16B
SOCKET SCREW, M3x16
內六角螺絲, M3x16

HMM3Z
NYLON NUT (M3)
止鬆螺帽(M3)

No.	Material No.	Description	名稱	Qty
1	BK2219	FRAME SPACER	六角連接支柱	1
2	HMC3-14B	SOCKET SCREW, M3x14	內六角螺絲, M3x14	2
3	HSA3-6	BUTTON HEAD SOCKET SCREW, M3x6	半圓頭內六角螺絲, M3x6	2
4	BK2563	METAL TAIL SUPPORT BRACKET (UPPER)	金屬固定座(上)	1
5	BK2564	METAL TAIL SUPPORT BRACKET (LOWER)	金屬固定座(下)	1

No.	Material No.	Description	名稱	Qty
6	BK0524-T	TAIL SUPPORT ROD	尾管支撐架	2
7	BK0447	TAIL SUPPORT ROD END	尾管支撐架接頭	4
8	HMJ2-8N	SELF TAPPING SCREW-M2x8	自攻螺絲(細)-M2x8	4
9	HMC3-16B	SOCKET SCREW-M3x16	內六角螺絲-M3x16	2
10	HMM3Z	NYLON NUT (M3)	止鬆螺帽(M3)	2

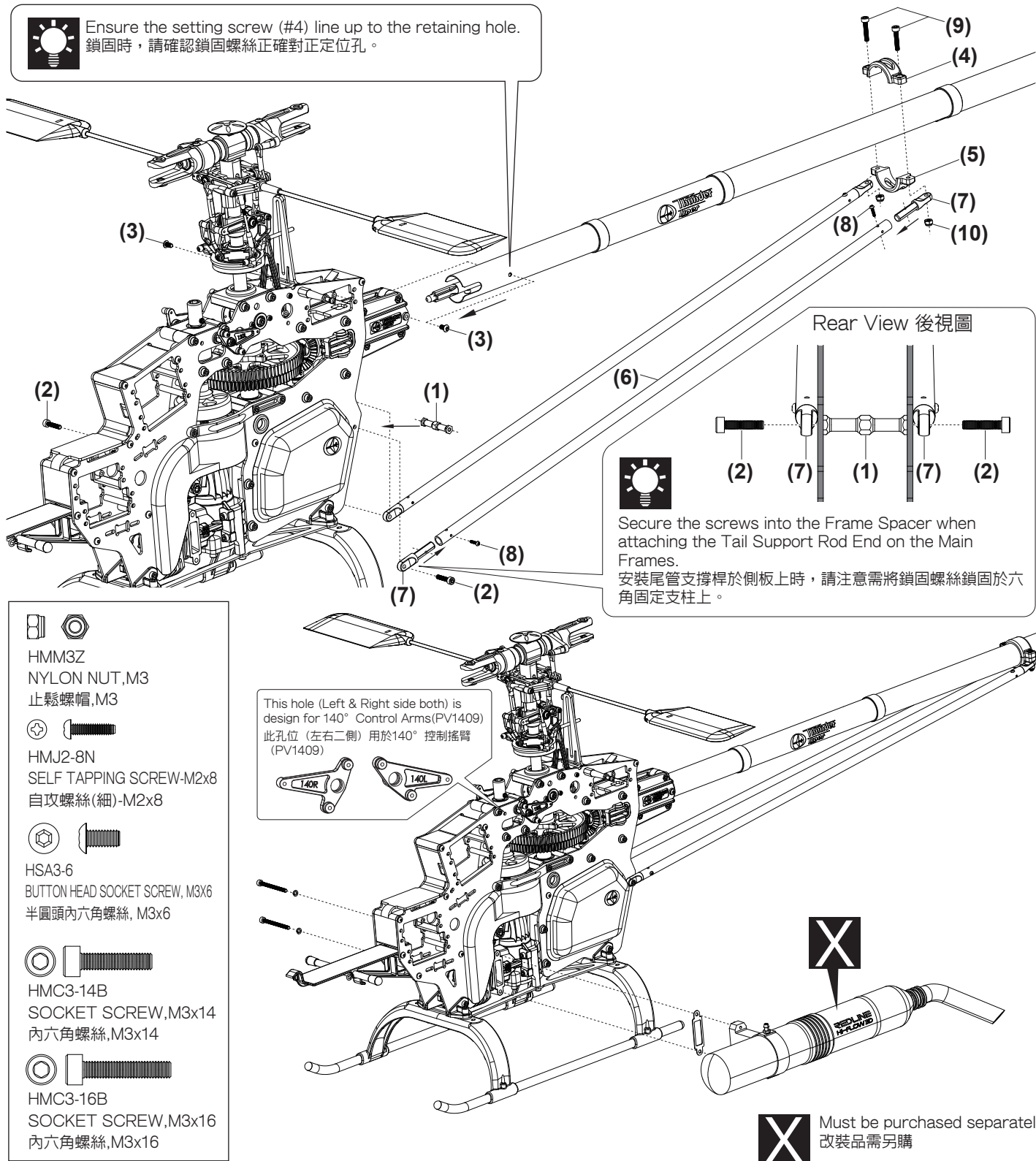

- HMM3Z
NYLON NUT, M3
止鬆螺帽, M3
- HMJ2-8N
SELF TAPPING SCREW-M2x8
自攻螺絲(細)-M2x8
- HSA3-6
BUTTON HEAD SOCKET SCREW, M3x6
半圓頭內六角螺絲, M3x6
- HMC3-14B
SOCKET SCREW, M3x14
內六角螺絲, M3x14
- HMC3-16B
SOCKET SCREW, M3x16
內六角螺絲, M3x16

No.	Material No.	Description	名稱	Qty
1	HSE2614N	BUTTON PHILLIPS TAPPING SCREW, M2.6X14	扁圓自攻螺絲(粗), M2.6X14	20
2	BK0104	SERVO MOUNTING	伺服機固定片	10



HSE2614N
 BUTTON PHILLIPS TAPPING SCREW, M2.6X14
 扁圓自攻螺絲(粗), M2.6X14

Attach the Servos onto the Servo Trays of Main Frame Set as drawing.
 參考圖示將伺服機裝入主側板組上伺服機座。



The distance from the center of the servo horn to both sides of the linkage balls should be the same.
 伺服機擺臂中心至兩邊球頭距離必需相等。

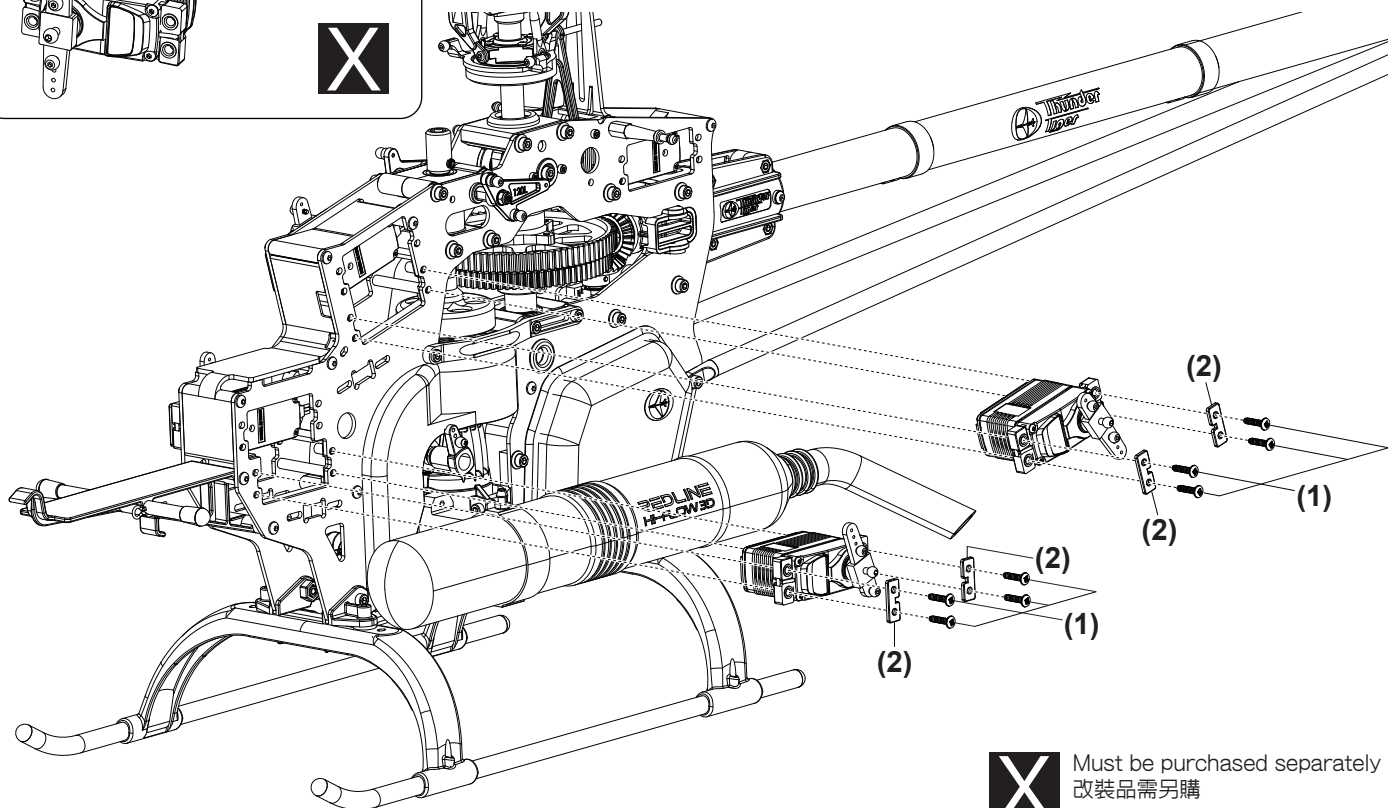
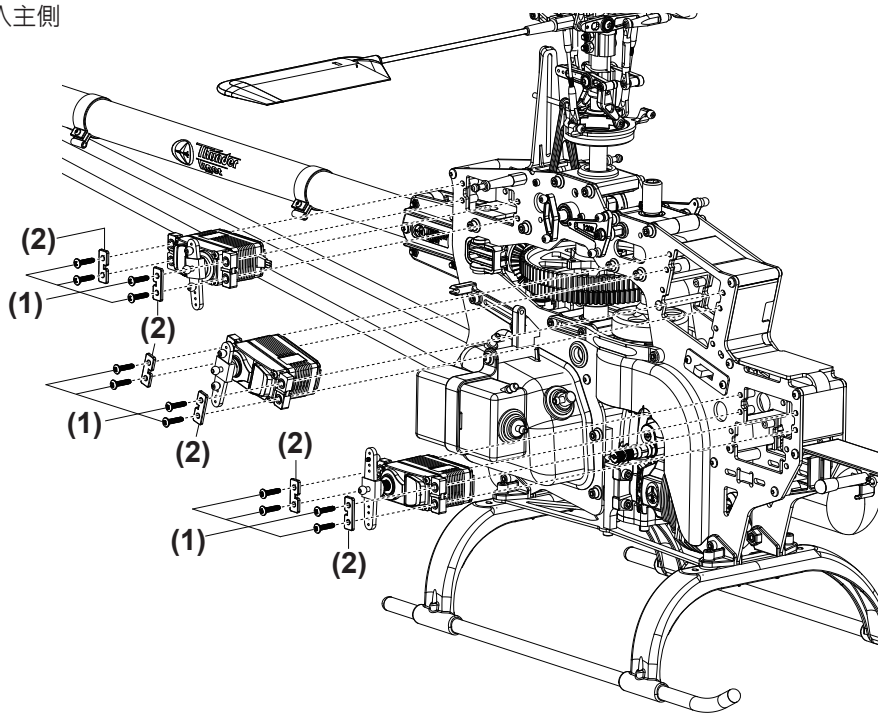
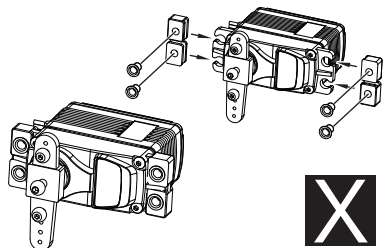
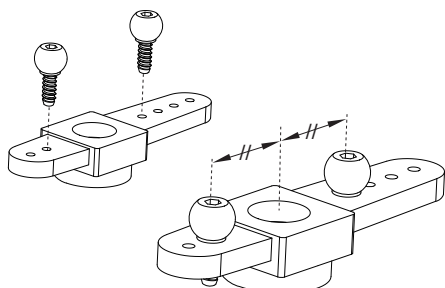

Must be purchased separately
 改裝品需另購

No.	Material No.	Description	名稱	Qty
1	HME4-3B	SET SCREW, M4x3	無頭內六角螺絲, M4x3	2
2	BK0105-1	TAIL CONTROL ROD JOINT	尾控制桿軸環	1
3	BK2195	TAIL SERVO LINKAGE ROD, 345mm	尾伺服機推桿, 345mm	1
4	BK0086	BALL LINK, d4.8x20	單頭連接桿, d4.8x20	20

No.	Material No.	Description	名稱	Qty
5	BK0175	LINKAGE ROD, 575mm	推桿, 575mm	1
6	BK0092	LINKAGE ROD, 30mm	連接桿, 30mm	4
7	BK2516	LINKAGE ROD, 45mm	連接桿, 40mm	4
8	BK0436	LINKAGE ROD, 55mm	連接桿, 55mm	1



The length may vary when using different servo, please re-adjust the length as actual condition.
連桿長度可能因搭配伺服機品牌不同而有所差異，可依實際情況調整。

HME4-3B
SET SCREW, M4x3
無頭內六角螺絲, M4x3

BK0086
BALL LINK, d4.8x20
單頭連接桿, d4.8x20

Assemble the Linkage Rods as drawings. The linkage length is measured by the center of the 2 Ball Links. These drawings are printed actual size; you can lay the linkage sets on the left drawings to measure the correct length.
請參考圖示組裝連桿及連桿頭。連桿長度距離的計算應以兩端連桿頭中心點為基準。圖示尺寸與實物相同，您可直接對照左方圖示以快速獲得正確長度。

Apply threadlocker
使用螺絲防鬆膠

Scale=1:1 (unit:mm)

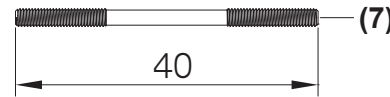
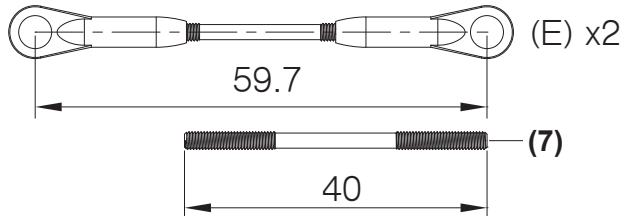
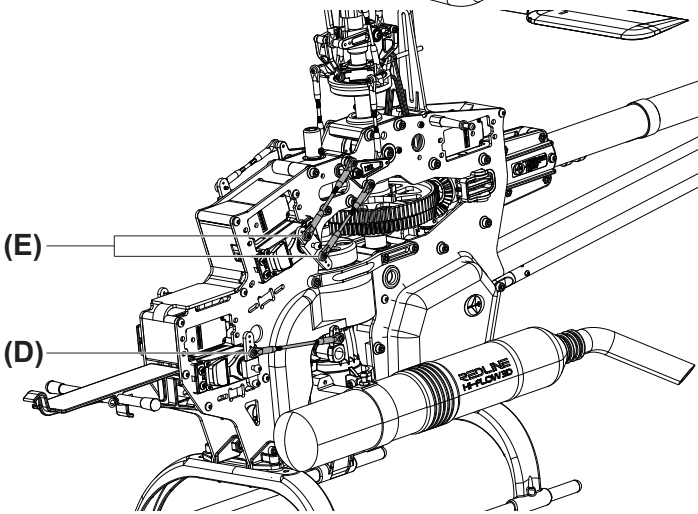
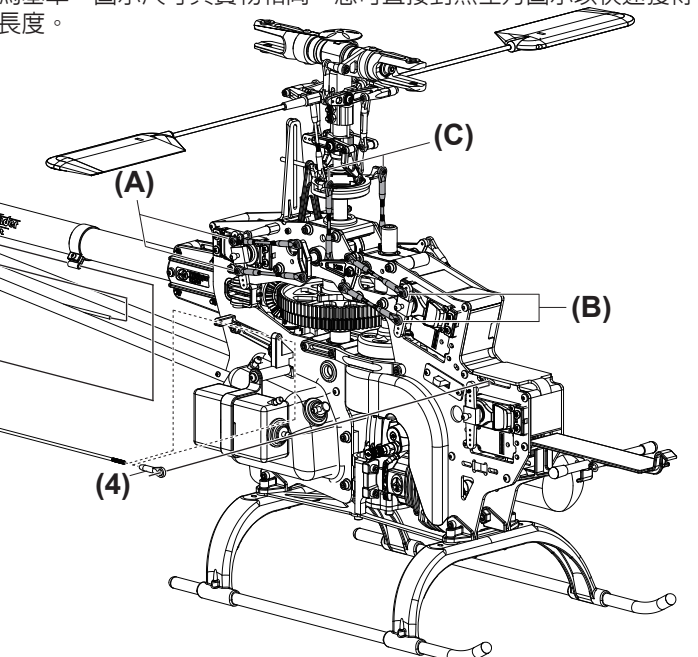
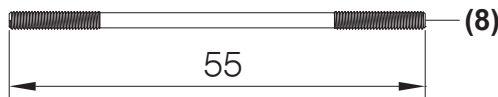
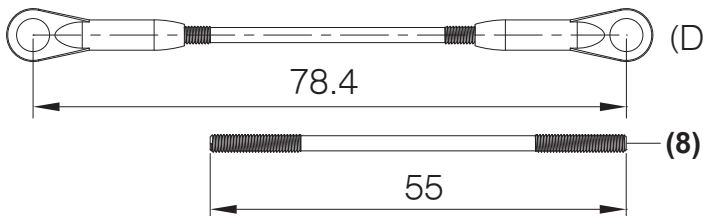
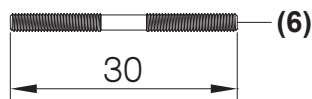
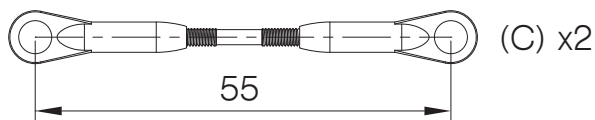
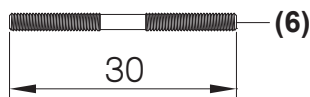
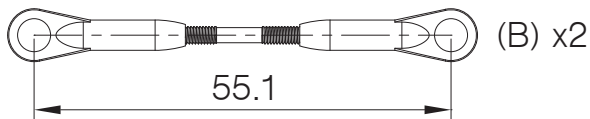
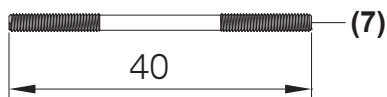
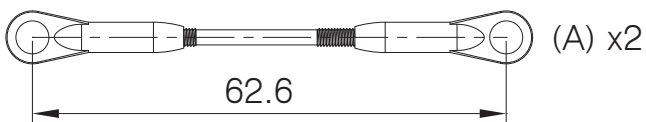

No.	Material No.	Description	名稱	Qty
1	BK2177-L	FRP CANOPY SET,X50	玻纖機殼組-藍	1
2	BK0102	RUBBER GROMMET	機身固定墊圈	2

No.	Material No.	Description	名稱	Qty
3	BK2278	CANOPY BRACKET	機殼固定座	1
4	HNX3-12B	S.B.H SELF TAPPING SCREW	半圓頭內六角自攻螺絲	2

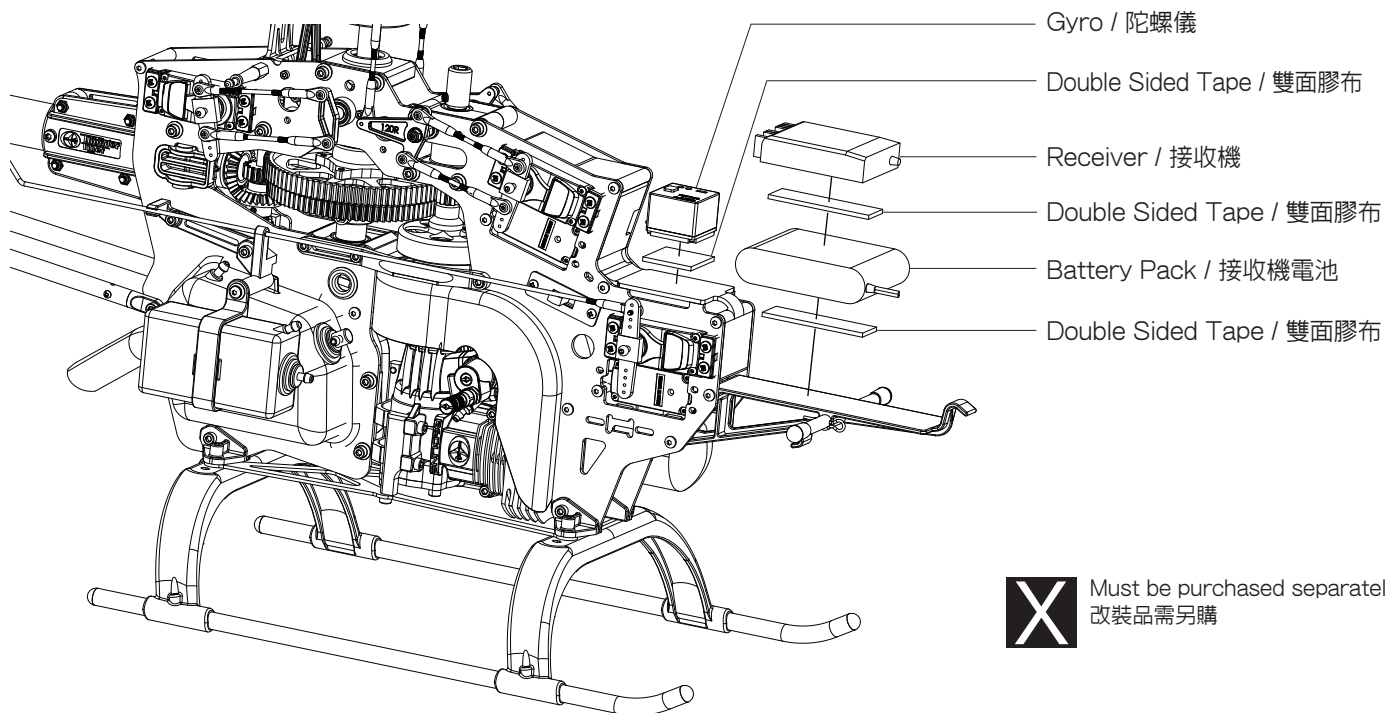

X Must be purchased separately
改裝品需另購

HNX3-12B
S.B.H SELF TAPPING SCREW
半圓頭內六角自攻螺絲

Assemble the fuel tube as drawing
油管組裝示意圖

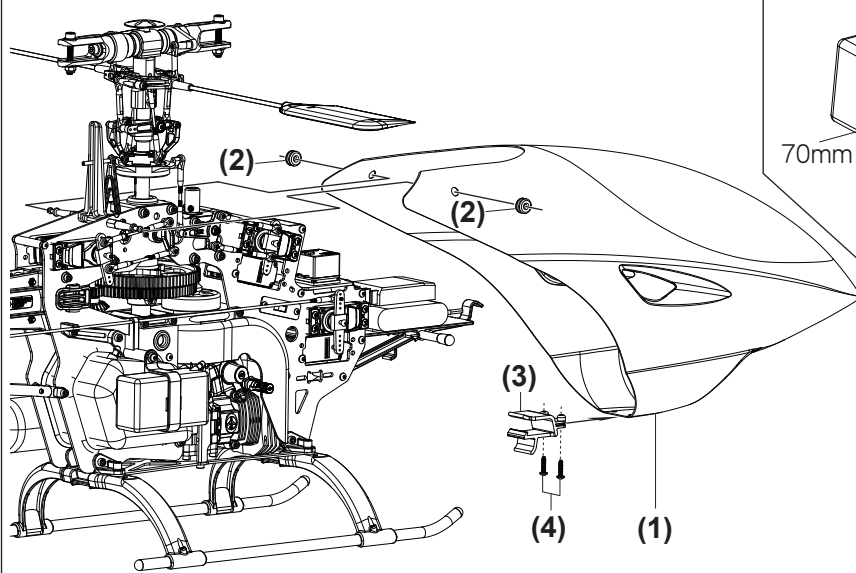

No.	Material No.	Description	名稱	Qty
1	HMC4-27B	SOCKET SCREW,M4x27	內六角螺絲,M4x27	2
2	HMM4Z	NYLON NUT,M4	止鬆螺帽,M4	2

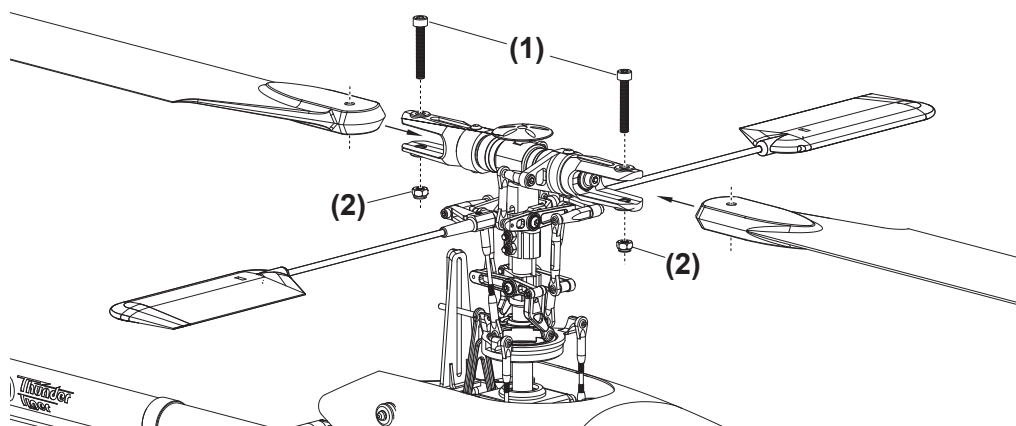

1. You may need to adjust the linkage to ensure the blade tracking. Please refer page 36, "Blade Tracking Adjustment."
 2. Install the main blades with the Socket Screw (HMC4-27B). Do not over tighten and ensure the blades run effortlessly.
 3. For safety the rpm of using carbon blades should not exceed 2600.
1. 您可能必需調整相關的連桿來確保旋翼旋轉軌跡正常。請參閱第36頁“主旋翼軌跡調整”說明。
2. 以內六角螺絲安裝上主旋翼。請勿過度鎖緊。
3. 安全起見，碳纖維主旋翼轉速請勿超過2600rpm。

Completed View

組裝完成

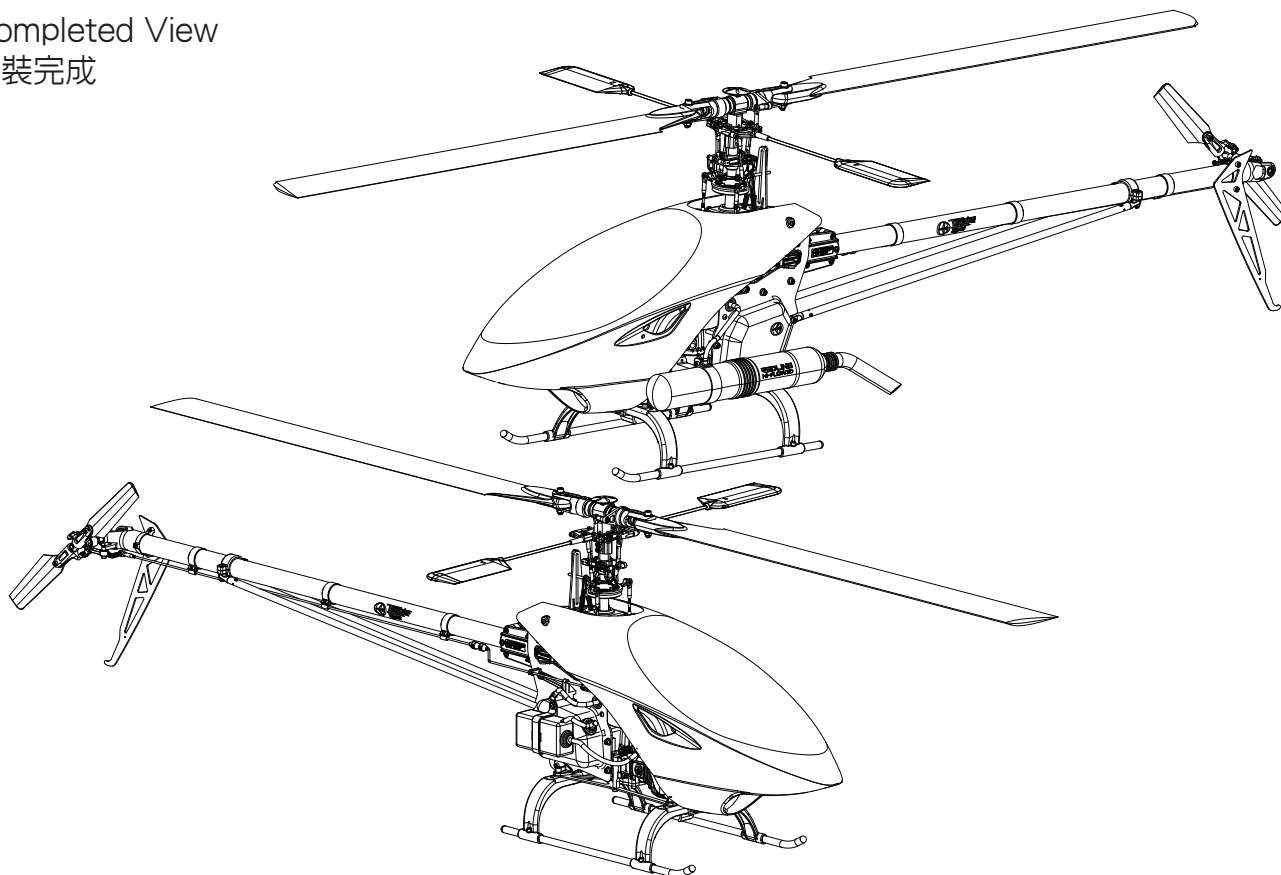

Engine Throttle Control Linkage / 引擎的飛行前調整

Mount the steel linkage ball to the outer hole on the plastic throttle arm. At full throttle stick, the carburetor hole should open completely. At low throttle and with the throttle trim all the way down, the carburetor hole should close completely. Adjust the ATV function in your transmitter to achieve the above requirement. Listen to the servo, it should not make any binding noise. Try to keep the throttle ATV between 90% and 110%. If your radio does not have ATV, then adjust the location of the steel link ball on the throttle servo arm to get the correct throttle travel.

當您裝置引擎時，建議您先在化油器的節氣閥先以油性簽字筆作關閉、中速、高速位置的記號，化油器控制搖臂裝置在機身時，必須調整至與油門伺服機控制搖臂平行的位置，通常我們建議以引擎中速位置與伺服機中速位置來作相互對照的調整依據，如此各個調整點才不會因為控制與被控制機構間的不同步，發生調整上的差異。

基本上由前面所要求的各項裝置數據均能滿足使用上的需求，當發生伺服機行程上的差異時，可以選擇使用遙控器上的ATV功能調整，但是我們建議調整的範圍雙邊（高、低速）不要有總合20%以上的調整差距，並儘可能的維持在90%到110%的範圍內。

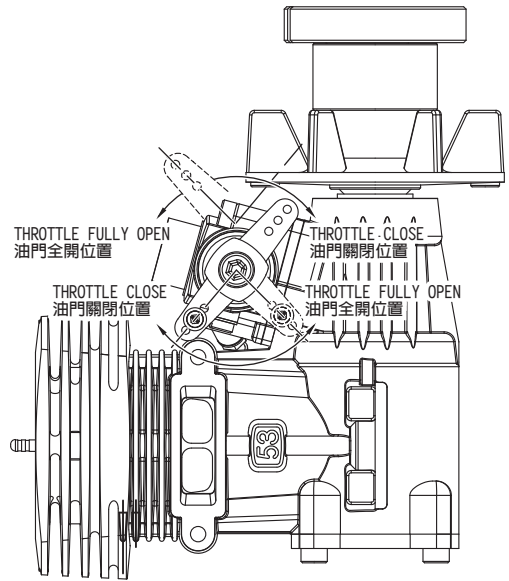

Electric Device Connection / 電子設備連接說明

E-CCPM system requires 3 channel for aileron, elevator and an AUX(for pitch). But people may get confused because the 3 channels are not referred to any independent movement. They are operated together to carry out the rolling, flipping and collective controlling. As a result, the following connecting manner is recommended.

The following chart is the E-CCPM connecting for your reference. Please also consult your radio instruction manual.

E-CCPM系統需要使用三個通路予副翼、升降舵、與螺距（使用AUX通道）。許多愛好者可能會對於此設定感到困惑，但是在混控模式下，必須藉由三類伺服機同時完成動作，因此建議依照下列說明完成伺服機與接收機連結。

下列圖示為安裝範例，實際接線方式，請參照您的遙控器使用說明書。

JR Radio Sysm

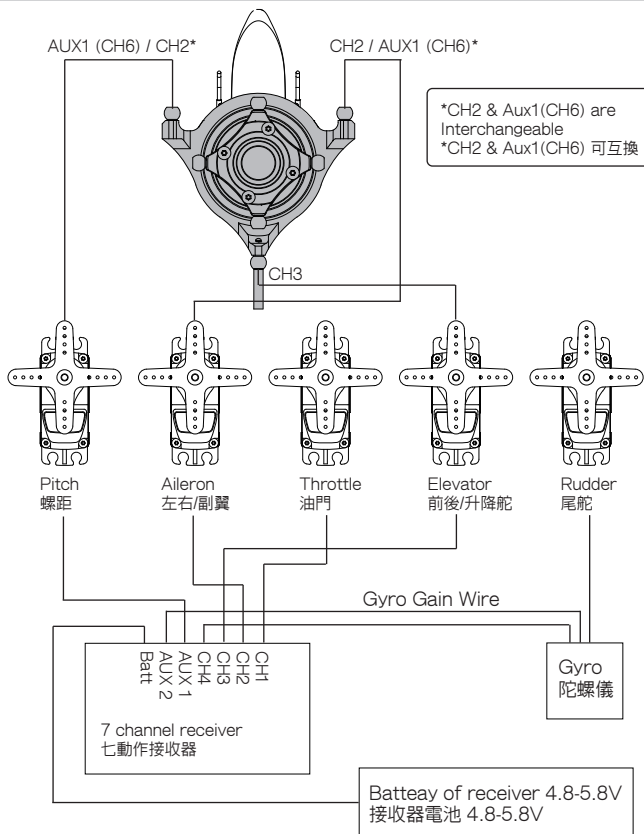

ACE RC / FUTABA / HITEC Radio Sysm

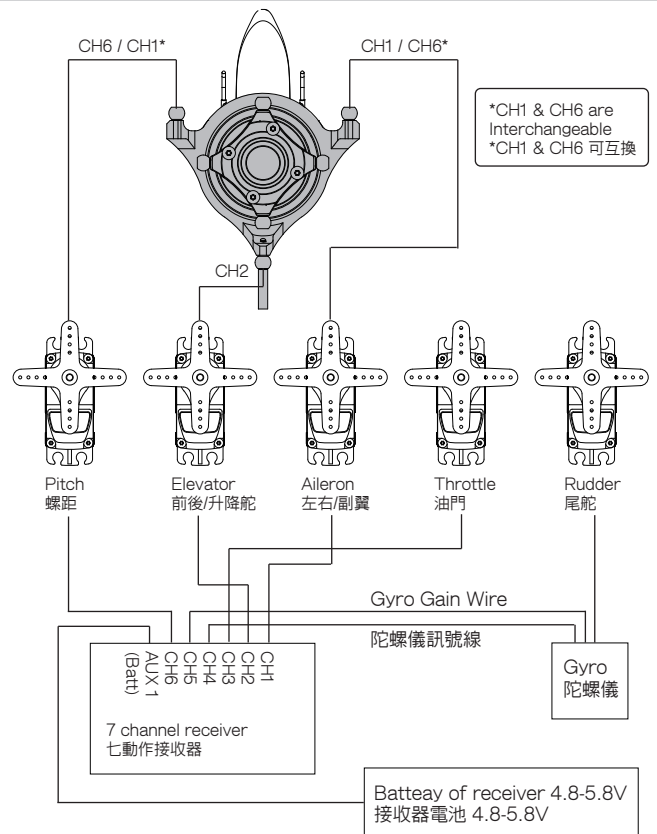

Configuring The Titan X50 / Titan X50 設定

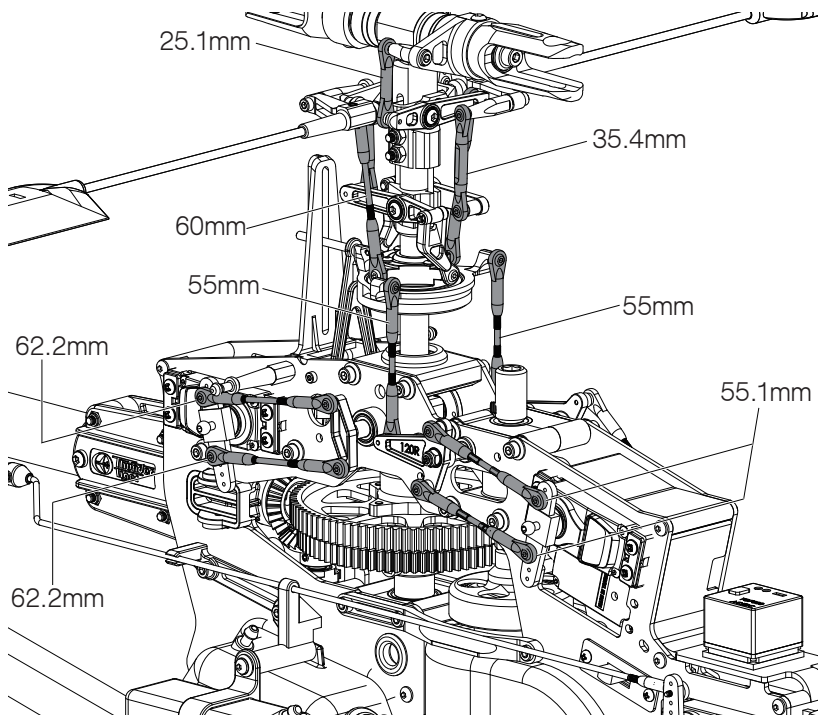

		5-Point Throttle Curves 5點油門曲線				
Normal	正常模式	0	35	50	65	100
Idle-up1	特技模式1	100	85	60	85	100
Idle-up2	特技模式2	100	85	60	85	100

		5-Point Pitch Curves 點螺距曲線				
Normal	正常模式	35	-	70	-	85
Idle-up1	特技模式1	10	-	-	-	90
Idle-up2	特技模式2	0	-	-	-	100
Hold	熄火降落	0	-	-	-	100

		Blade Pitch Angles (degrees) 螺距角度		
Normal	正常模式	-4	6	10
Idle-up1	特技模式1	-12	0	12
Idle-up2	特技模式2	-15	0	15
Hold	熄火降落	-15	0	15

 The settings may differ, the table is for your reference only.
每人操作習慣或有不同，僅供參考。

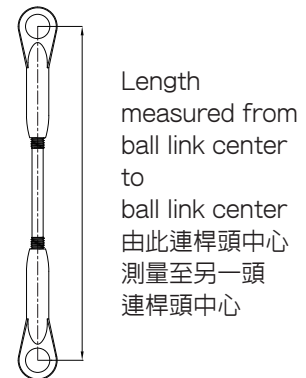
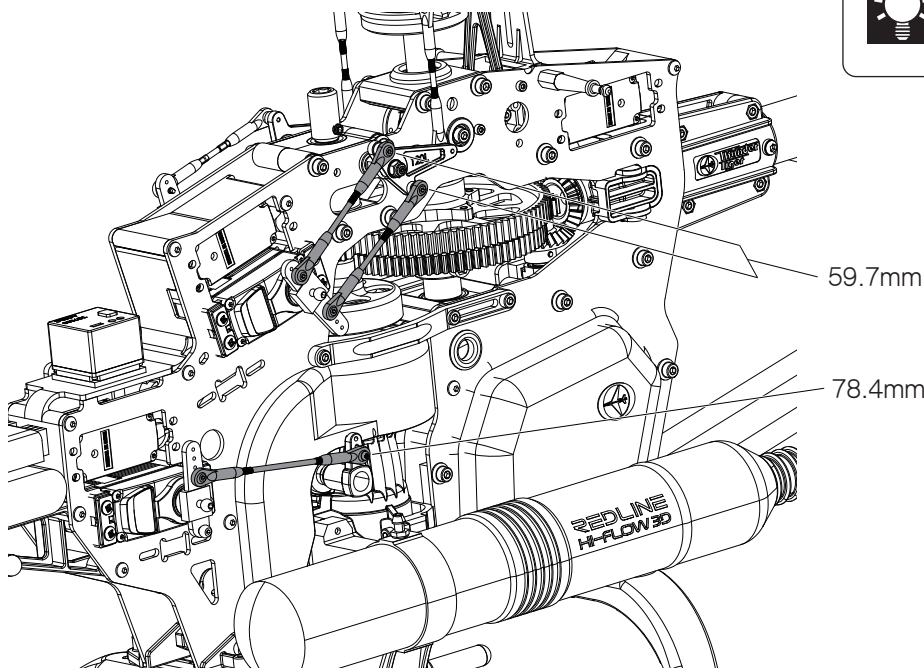

The above pushrod lengths permit 3D flying with the Titan X50.

Use these lengths as a starting point. Pushrod lengths are measured from ball link center to ball link center. Suggested throttle and collective pitch set up: Idle-up1 is for continuous 3D flying and aerobatics. Idle-up2 is for those who have very good collective pitch management skills. Use a pitch gauge to check blade angles. It is easier to start setting up idle-up2 blade pitch angles first. For safety, to inhibit idle-up modes and just use a normal mode setting for a novice is recommended. The model should hover at around 1550 rpm in normal mode, and flies at around 2000rpm in idle-up1/2. With 1700 or higher headspeed, the use of carbon/FRP blades is recommended.

以上為 Titan X50 直昇機之3D飛行連桿長度設定值。這些設定值可作為初始設定時之參考標準。

在螺距及油門曲線設定方面，建議設定兩個特技模式。進行連續3D飛行時使用特技模式-1，而進行倒飛練習時則可使用特技模式-2。此外，建議初學者暫時不要使用特技模式進行練習。

至於轉速的設定方面，建議停懸及特技模式之轉速分別為1550rpm及2000rpm。

建議當轉速高於1700rpm以上時，請將主旋翼更換為玻璃纖維或碳纖維主旋翼。切記！即便使用高性能碳纖維主旋翼，轉速仍有其上限，請參照旋翼的使用說明，切勿超轉使用。

The performance of any RC helicopter and how well it fly depends strongly on how the model has been set up. Before you start, please make up the length of all the pushrods according to the recommended length. The pushrod lengths we have provided are valid for beginners to expert 3D flying. Then, we recommend using the reset function on your transmitter to reset all settings to factory default values. Check the end point adjustment or ATV value, on your transmitter to make sure the values are at 100%. Next we recommend program the numerical value we have provided in the table for the five points in the throttle curves and the collective pitch curves. Now you can proceed to do the mechanical adjustments.

Throttle Adjustment.

The throttle arm on the carburetor should always be parallel to the throttle servo arm. When the throttle barrel is half open, the throttle arm should be straight down. Leave it at this position. Turn on the transmitter and leave the throttle in the normal throttle mode. Set the throttle trim to the bottom and set the throttle stick to the middle. Adjust the throttle pushrod to the correct length. Check the throttle servo travel direction to confirm moving the throttle stick to the high position will move the throttle arm to the full open position. When the throttle stick is moved to the highest or the lowest position, it will fully open or fully close the throttle arm without binding.

在遙控直昇機的領域中有句老話：三分飛行，七分調整。意即一架遙控直昇機好飛與否或性能優劣，取決於調整與設定的恰當與否。為了讓消費者可以更瞭解 Titan X50 並進行最佳之設定，本節將一步一步說明機體與遙控器的設定方式，以完全發揮 Titan X50 直昇機的飛行性能。在開始設定之前，請按照前述之3D連桿設定長度，將機體之連桿調整至適當長度。該連桿長度適用於初學者及高階玩家。此外，建議將遙控器所有參數歸零至原廠初始值，並將所有頻道之行程量調整至100%。接下來將油門曲線與螺距曲線調整至本說明書所提供之數值，以作為初始設定。再來便可以進行更細部的設定了。

油門調整

在正常模式之下，確認油門伺服機之正逆轉，將油門微調置於熄火位置，選擇適合之油門伺服機擺臂、適當之球頭孔位，並調整油門連桿長度與遙控器之油門ATV值，使其正負值相近且接近100%，並使其在高速與低速的位置下確定化油器全開與全關，如此便完成油門行程之設定。在理想狀況下，引擎化油器之擺臂應該與油門伺服機之擺臂平行，而當化油器開啟於中速狀態，伺服機與化油器擺臂應均是接近垂直的。

Collective Pitch Setup 螺距設定

Since you have been setting the lengths of the pushrod as mentioned, the linkage should be centered well as described below.

若您已經依照前述參數設定油門對螺距曲線，連桿應會如下處於置中位置。

Centering

1. The elevator and aileron control levers should be as the drawing below while centering the collective pitch stick.
2. Parallel the flybar, the main blades should be at 0 degree and the swashplate should be level.

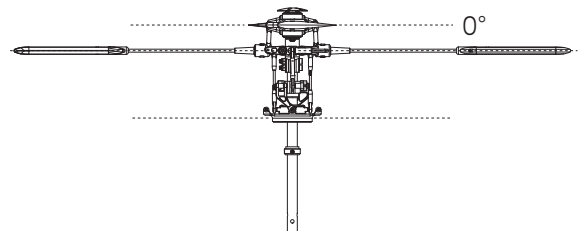

中立點

1. 當發射機螺距撥桿置中時，升降舵面及副翼控制搖臂位置應成水平狀態。
2. 主旋翼與穩定翼平行，兩者間角度為0，且十字盤為水平狀態。

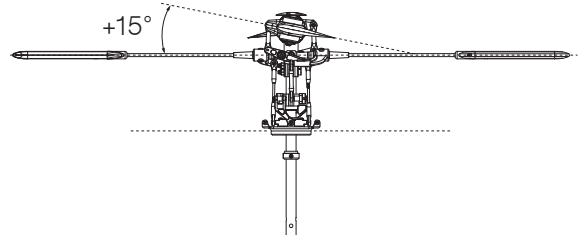

Maximizing

1. Place the collective stick at high end.
2. The main blades should be at +15 degree and the swashplate should be level.

最大螺距設定

1. 將發射機螺距撥桿上推至最高點。
2. 主旋翼相對於穩定翼呈+15度角，且十字盤為水平狀態。

Minimizing

1. Place the collective stick at low end.
2. The main blades should be at -15 degree and the swashplate should be level.

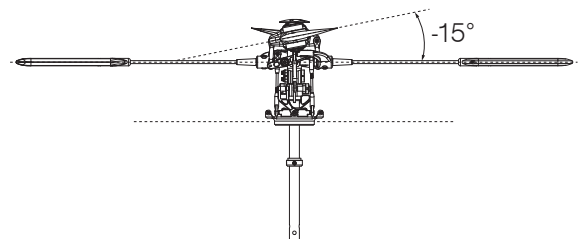

最小螺距設定

1. 將發射機螺距撥桿上撥至最低點。
2. 主旋翼相對於穩定翼呈-15度角，且十字盤為水平狀態。

NOTE1: The steps above defines the limits of the collective pitch setting.

NOTE2: The setting of the maximum collective pitch depends on your personal flying skill and style. Too much collective pitch could overload the engine and drive system.

說明1：上述步驟在設定主旋翼螺距的範圍值。

說明2：請依個人飛行技巧及習慣來設定最大螺距。過大的角度會增加引擎及傳動系統的負荷而縮短壽命。

Setting Up Data For Your Reference 參數設定參考



The following is the setting up data of pitch curve and throttle curve for your reference only. Please ask experienced pilot to help you if you have never done this before.

下列參數設定僅供參考，請依實際狀況進行調整，或詢求有經驗的玩家協助。

Beginner / 一般飛行

Throttle Curve 油門曲線

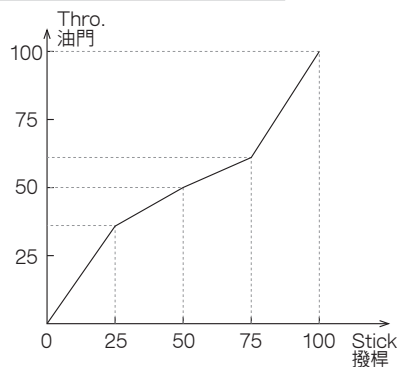

Pitch Curve 螺距曲線

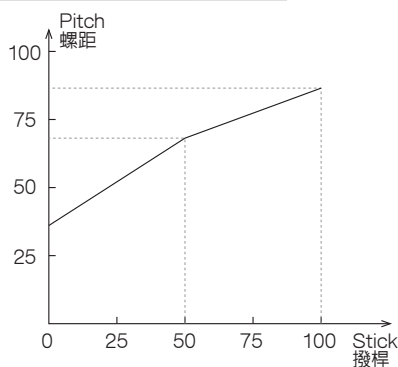

Throttle Curve 油門曲線

	0	25	50	75	100
Normal 一般飛行	0	35	50	65	100

Pitch Curve 螺距曲線

	0	25	50	75	100
Normal 一般飛行	35	-	70	-	85

Pitch Curve 螺距曲線

	0	25	50	75	100
Normal 一般飛行	-4°	-	+6°	-	+10°

3D

Throttle Curve 油門曲線

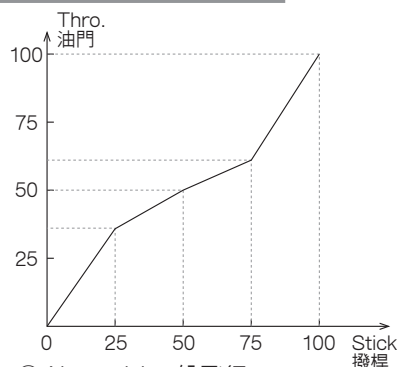

◎ Normal / 一般飛行

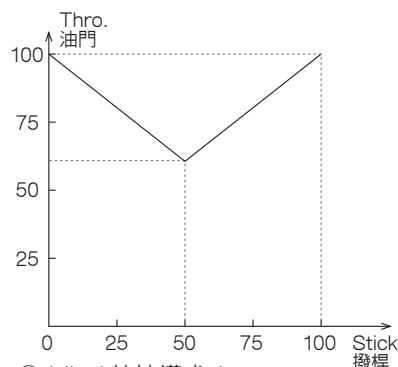

◎ Idle / 特技模式 1

Throttle Curve 油門曲線

	0	25	50	75	100
Normal 一般飛行	0	35	50	65	100
Idle-up 1 特技模式 1	100	-	60	-	100

Pitch Curve 螺距曲線

	0	25	50	75	100
Normal 一般飛行	35	-	70	-	85
Idle-up 1 特技模式 1	0	-	-	-	100
Hold 鎖定模式	0	-	-	-	100

Pitch Curve 螺距曲線

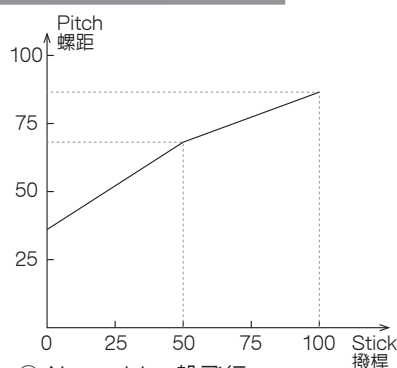

◎ Normal / 一般飛行

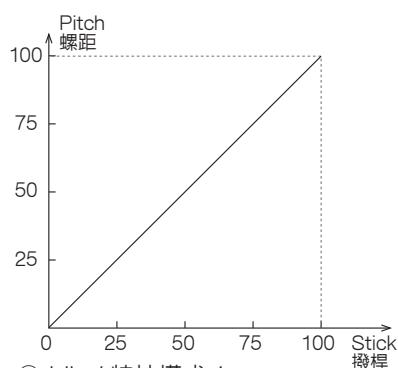

◎ Idle / 特技模式 1

Pitch Curve 螺距曲線

	0	25	50	75	100
Normal 一般飛行	-4°	-	+6°	-	+10°
Idle-up 1 特技模式 1	-15°	-	-	-	+15°
Hold 鎖定模式	-15°	-	-	-	+15°

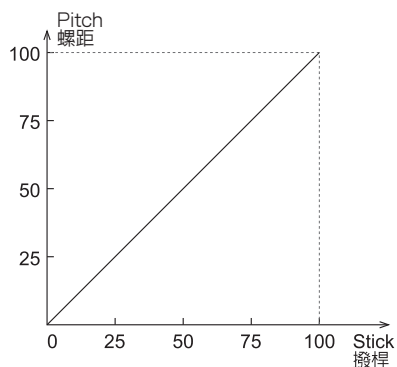

◎ Hold / 鎖定模式

⚠ WARNING 警告

1. Too much collective pitch will bring about too much loading to the engine and drive system.
 2. Too much headspeed will lead to blades (grips) explosion.
 3. It's very dangerous for setting the headspeed over the blades (grips) limit.
 4. Please do not set the collective pitch to the maximum (± 15) unless you have very good collective pitch management skill.
1. 過大的聚合螺距設定會使引擎及傳動系統超載。
 2. 過快的主旋翼轉速會造成主旋翼轉座崩裂或射槳。
 3. 將旋翼轉速設定超過槳片負載極限極端危險!
 4. 請勿將聚合螺距設定超過最大值 (+15度角)。

Tail Control And Gyro Setup 尾舵控制及陀螺儀控制



It is recommended to use a Heading Lock Gyro. With a Heading Lock Gyro, you may not use the trim and the revolution mixing function of tail control.

First, choose the length of the tail servo arm referring to the manual of the Gyro. You may try 13.5mm as the starting setting. Then mount the servo arm for the moment and check the movement of the tail servo:

1. While giving the right rudder control, the servo arm should move toward the nose of helicopter.
2. Rotate the helicopter with your hand counterclockwise, the servo arm should move toward the nose of helicopter.

建議搭配鎖頭式陀螺儀，可使您無需額外設定微調及混控功能來控制尾舵。

首先，參考陀螺儀說明書來選用尾舵伺服機擺臂長度，建議初始可先設定為13.5mm。暫將伺服機擺臂固定後進行尾舵伺服機作動確認：

1. 當執行右舵時，伺服機擺臂應朝機頭方向作動。
2. 將整台直昇機逆時針旋轉時，伺服機擺臂應朝機頭方向作動。

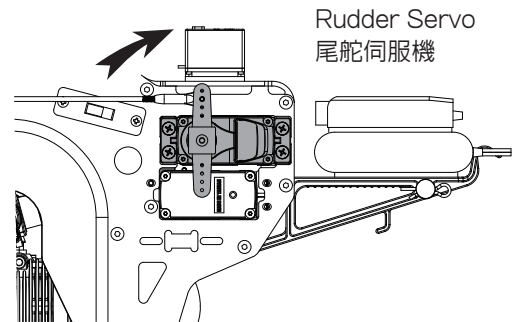
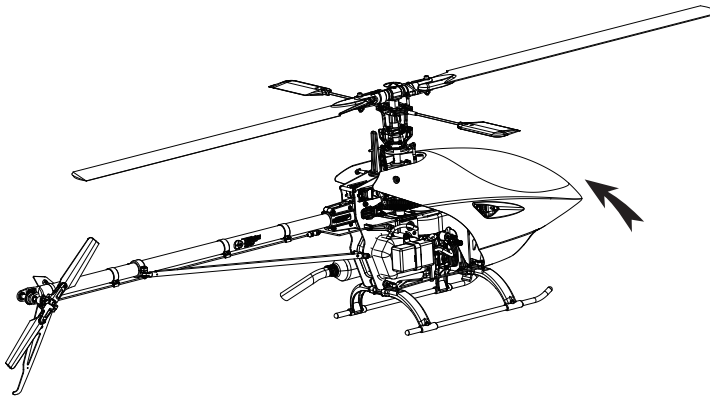

After ensuring the moving direction of tail servo, you have to mount the servo arm in the correct position. Please reset the receiver power and do not move the helicopter. While the tail control stick and trim are centered, mount the servo arm vertically. If you cannot mount the servo arm vertically, please try another servo arm. Next, two points may be your concern:

1. The traveling limit of the rudder servo may not go beyond the mechanical movement.
2. The rudder servo arm should be vertical while the tail rotor are at 0 pitch or with a little offset to the right. (Referring to the photo below)

確認尾舵伺服機動作正確後，即可將伺服機擺臂確實安裝固定；請勿移動直昇機並重新啟動接收機電源。

當尾舵撥桿與微調置中時，將伺服機擺臂垂直尾管安裝固定。若無法正確垂直，請更換合適的擺臂。接著，請特別注意下列兩者：

1. 尾舵伺服機最大行程量切勿大於機械行程量。
2. 當尾旋翼螺距為0或稍偏向右時，尾舵伺服機擺臂應在垂直位置。（請對照下圖）

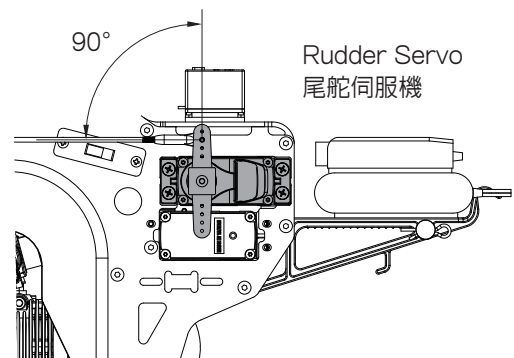
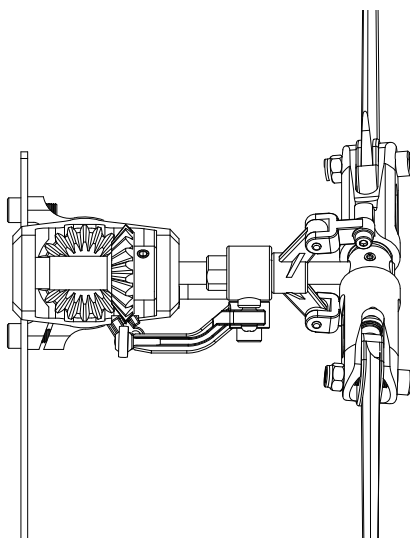

Note1: To find the traveling limit, you have to adjust the Gyro referring to its manual.

Note2: To adjust the pirouetting speed of the helicopter, please use the "Travel Adjustment" or the "D/R & EXP" function of your transmitter.

說明1：請參考陀螺儀說明書調整陀螺儀以確認伺服機最大行程量。

說明2：調整尾舵自旋速度，請設定發射機上“行程設定（Travel Adjustment）”或“大小動（D/R）、指數值（EXP）”功能。

Swashplate Type Setting / 十字盤模式設定



Set the model type for helicopter in your Transmitter and set the swashplate type as 120° CCPM. Refer your Transmitter manual to find a proper swashplate setting.

請參閱遙控器說明書，設定正確之十字盤設定模式。

Nose / 機首方向

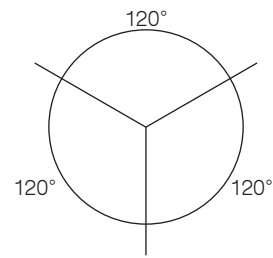

Swashplate & Servo Movement Setting / 十字盤及伺服機動作設定



As going through these setup procedures, ensure there is none of the controls bind at full travel.

Next, please refer below illustrations to ensure the direction of servo movement and swash mixing settings are correct for the controls properly.

在繼續設定之前，請先確認伺服機及連桿動作皆順暢可達最大作動量。

然後，請參考下表圖示，確認伺服機動作及十字盤混控設定可正確對應撥桿動作。

	Model 1	Model 2	Servo Horn movement 伺服機擺臂動作	Check Point 機構動作確認
Aileron 副翼				
Elevator 升降舵				
Pitch 螺距				
Throttle 油門				
Rudder 尾舵				

If the movements of servos or swashplate are not correct, please adjust the servo reverse settings for one or more channels in your Transmitter.

若伺服機或十字盤作動方向不正確，請調整您遙控器上個別的伺服機逆轉功能。

Blade Tracking Adjustment 主旋翼軌跡調整



! CAUTION / 警告

For safety, ensure to keep a safe distance from the helicopter at least 10 meter (30 feet) while making tracking adjustment.

安全起見，進行主旋翼軌跡調整時，請至少與直昇機保持10米（30呎）的安全距離。

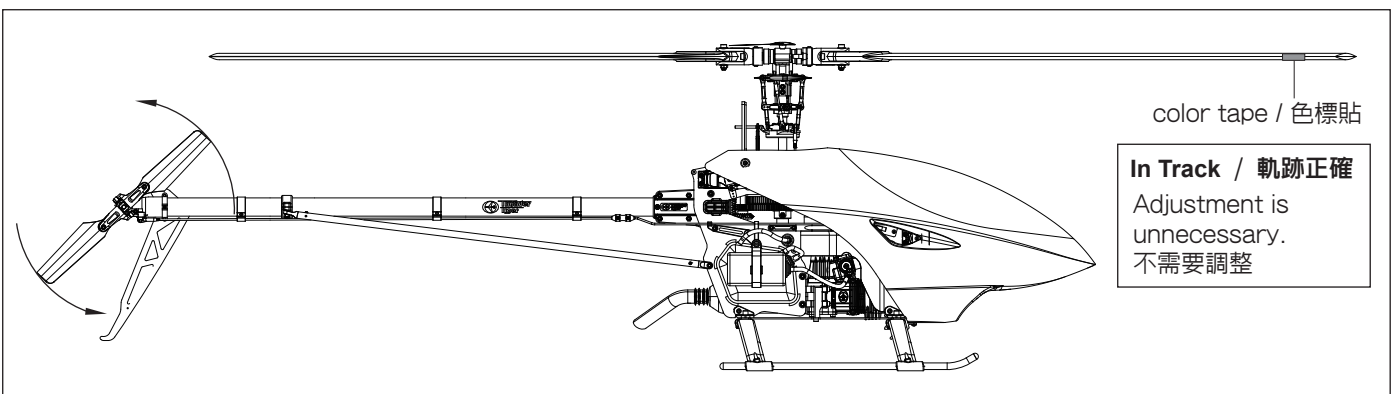
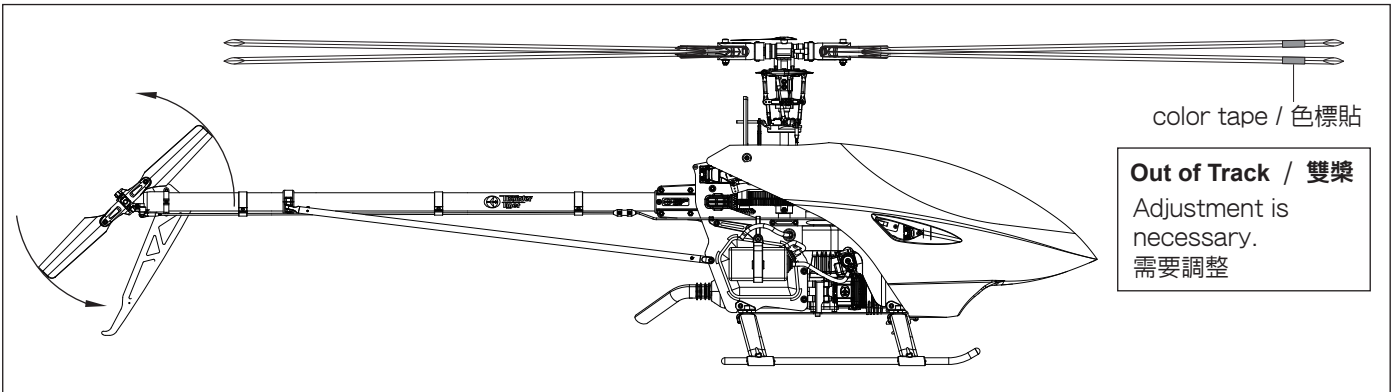

1. Use a color tape at the tip of main blades for tracking identification easily.
2. Increase the main blade speed to just before the helicopter lifts-off.
3. Observe which blade appears to be lower than the other, and increase the pitch of the lower blade one turn of the Linkage Rod C (refer Page 11) at a time until each blade runs in track. If both main blades rotate in the same path, it doesn't need to be adjusted.

1. 在主旋翼前端貼上色標可方便辨識軌跡。
2. 提高主旋翼轉速使機體稍懸浮於地面。
3. 觀察兩支旋翼軌跡是否有落差（雙槳），調整軌跡較低旋翼上的連桿C（參閱第11頁）長度，一次調整一圈，直至兩支旋翼軌跡一致。若軌跡一致則無需調整。

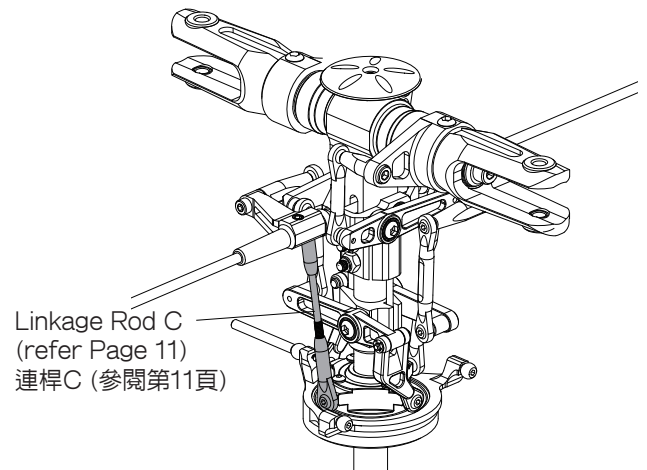

! CAUTION / 警告

Out of track causes vibration, instability and a loss of power due to additional drag. Please adjust the tracking repeatedly until the blades are in track properly.

旋翼軌跡落差（雙槳）會造成直昇機震動、不平衡及損失動力。請務必進行調整以使旋翼軌跡精準正確。

After Flight Checklist 飛行後的檢查項目



- (1) Check every screw and bolt to make sure none has loosened due to vibration.
 - (2) Check every rotating and movable part to ensure they still move smoothly and normally.
 - (3) Clean off the exhaust residue from the muffler, engine, and helicopter.
 - (4) Check all movable parts, such as gears, ball links, belt, etc. for unusual wear.
- (1) 每次飛行後必須詳細的檢查機體的各部位螺絲有無鬆動情形，若發生鬆動必須確實鎖緊再進行下飛行。
- (2) 每次飛行後檢查每一個轉動部位（含單頭連接桿）均能順暢的運作。
- (3) 排氣管、引擎、直昇機本體必須確實的清潔。
- (4) 檢查每一個動作部位，加齒輪、球頭、皮帶等。

Trouble Shooting 異常處置



[1] The engine will not start.

- * The engine starting shaft will not turn:
The engine may be flooded with too much fuel. Please remove the glow plug first, then turn the engine with the electric starter until the excess fuel spits out of the glow plug hole.
- * The engine turns when the electric starter is applied, but the engine will not start:
 - (1) Is the glow plug working? Remove the glow plug and does the platinum coil glow red when a 1.5 volt battery is applied to the plug? If not, then the glow plug battery may be weak and old.
 - (2) Is the carburetor needle properly set? Please refer to the engine instruction manual for the proper needle setting.
 - (3) Does the throttle control arm move properly and in the correct direction according your transmitter command?
- * Engine will start, but quits immediately.
 - (1) Use the transmitter to increase the carburetor opening slightly. The throttle stick should never exceed the 1/3 position when starting the engine.
 - (2) Try a new or different type of glow plug. There are different types of glow plugs on the market for different types of fuel and operating conditions. Seek the advice of experienced fliers and also experiment with different types of glow plugs until you find the one that suits your operating condition the best.
- * Engine runs, but the helicopter will not lift off.
 - (1) Check the main rotor blade pitch angle, they should be set at 5.5 to 6 degrees when the transmitter throttle/collective stick is at the center position.
 - (2) Does the engine throttle arm move properly? The carburetor opening should be fully open when the transmitter throttle/collective stick is moved up. The carburetor opening should be nearly closed when the transmitter throttle/collective stick is moved down. And the opening should be completely closed when the transmitter throttle/collective stick is moved down and the throttle trim is also moved down.
 - (3) Check your engine manual for proper starting point settings. Then try again to start your engine. If smoke is excessive when adding throttle your high speed needle may be too rich. Try a few clicks turning clockwise and try again. Once proper needle settings are achieved, model should lift off effortlessly.

[2] Helicopter problems.

- * The helicopter shakes.
 - (1) Is the flybar bent?
 - (2) Is the flybar bent?
 - (3) Is the main rotor shaft bent?
 - (4) Are the two control paddles mounted at the same distance from the rotor shaft, and the paddles are parallel to each other, and in the proper direction?
 - (5) Is the tail rotor shaft bent? The tail rotor blades mounted properly or damaged?
 - (6) Are the main rotor blades damaged or mounted in the proper orientation? The blades may require additional balancing. The blade balance can be checked by removing both blades and then use one of the 4mm blade bolt and nut to hold the two blades together like a teeter totter. Then, hold the blade bolt with your thumb and index finger. The two blades should teeter and remain in a level position. If not, then add some tape to the lighter blade near the blade tip until the two blades teeter in a level position. Hobby shops also sell blade balancers that are designed solely for balancing model helicopter blades.

1. 引擎無法啟動或無法正常起飛時：

當引擎啟動軸無法轉動時：

將您的機身拆下，由前側將火星塞拆下，重複使用啟動器的程序，直到引擎內積存的燃油排出為止，再將火星塞鎖回去，重複啟動的程序。

當引擎可以轉動，但是無法順利啟動時：

1. 檢查電夾是否有足夠的電源，可以將預備的火星塞接到電夾上作確認，若電夾顯示正常，可能需要更換一個新的火星塞。
2. 化油器的油針設定是否需要重新設定？請檢查主副油針的相關設定。

3. 試著將油門微調調高或是將油門控制桿稍微往上推，再進行啟動程序，較低的油門設定可能無法順利啟動引擎。

引擎啟動後馬上熄火的處置：

1. 引擎啟動後，加速的動作稍微減緩，當引擎的低速油針設定的較富油時，可能會發生此狀況。

2. 試著更換多種其他類型的火星塞，依據您所使用的燃油、引擎來選擇最適用的火星塞。

引擎已經啟動，但是無法正常起飛：

1. 檢查主旋翼的攻角，在中速位置主旋翼的攻角應該是在5.5~6度的範圍。

2. 檢查當油門推桿在高速位置時，能夠讓節氣閥達到高速的位置；當低速時，節氣閥必須在接近關閉的位置。

3. 化油氣的油針是否位做適當的設定？先順時針旋轉將主油針關閉，再逆時針放開約2~2.5圈（此設定值請參考同好之間的設定或是各廠牌引擎的說明書建議值），引擎的排煙若是顯得較少，並有咳嗽的聲音發出，此時引擎呈現貧油的現象，必須鬆退油針；當引擎顯得無力，並由消音器中噴出許多燃油時，此時引擎是處於富油的情形，必須適時的鎖進少許油針。

2. 直昇機的問題

機體發生明顯的震動時：

1. 檢查平衡桿是否兩端長度不一致或是彎曲。

2. 檢查主軸是否彎曲。

3. 檢查主旋翼兩端轉座是否跟主軸等距。在組裝旋翼頭時，若未於旋翼緩衝橡皮上油，可能會發生橫軸位置偏移的現象，此時當直昇機低速時會發生明顯的機體震動現象。

4. 尾旋翼軸是否彎曲？尾旋翼轉座是否鬆動或損毀？尾旋翼是否有單邊毀損的情形？

5. 主旋翼出廠前均已做過嚴謹的配對檢驗工作，但使用時仍必須再次進行主旋翼的重心、重量微調，您可以使用市售的主旋翼重心調整器來作旋翼重心的調校標準。在直昇機套件的貼紙中或主旋翼中均附有寬度約1公分的重心調整用貼紙，當主旋翼裝置在重心調整器上，裁剪適當長度大小的貼紙貼在較輕一端的主旋翼上，將可改善因主旋翼重心、重量不均所產生的震動問題。

6. 主旋翼以及尾旋翼的鬆緊度必須一致，若有單一側較緊的情況，也可能造成機體震動。

SPARE PARTS / 零件包



1179
SILICONE FUEL LINE, 2ft
耐熱油管(透明), 2ft

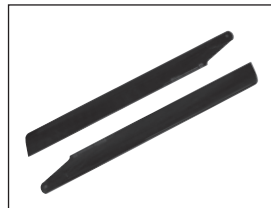

3878
TT V2 CARBON BLADE 600mm
碳纖主旋翼600mm

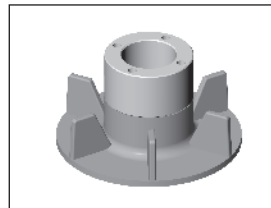

AV0143
COOLING FAN
冷卻風扇

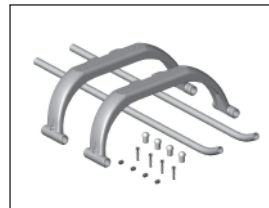

PV0035-2
LANDING SKID SET
腳架組



PV0035-3
LANDING SKID
腳架



PV0041
BALL LINK
單頭連接桿

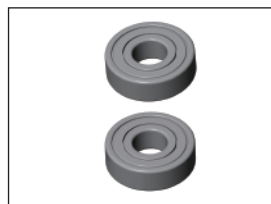

PV0050
BEARING SET, d5xD13xW4
軸承組, d5xD13xW4

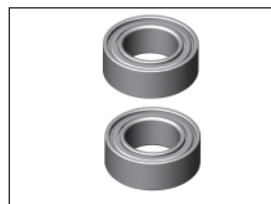

PV0051
LEAVER BRG, d4xD7xW2.5
軸承組, d4xD7xW2.5



PV0052
TAIL SLIDER BRG, d6xD10xW3
軸承組, d6xD10xW3

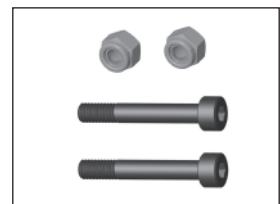

PV0053
ROTOR BOLT
主旋翼螺絲組

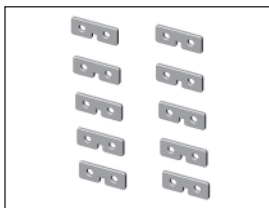

PV0054
SERVO MOUNTING PLATE
伺服機固定片組

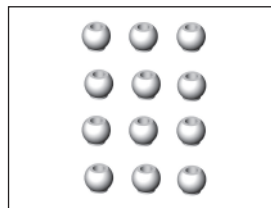

PV0058
LINKAGE BALL
連接頭

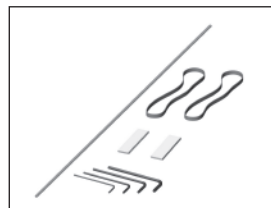

PV0060
INSTALLATION SET
組合附件包

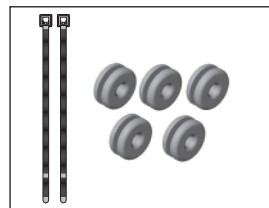

PV0062
RUBBER GROMMETS(WHITE)
機身固定墊圈組

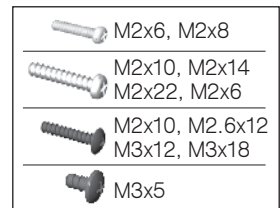

PV0088
SCREW BAG(6 PCS EACH)
圓頭十字螺絲組

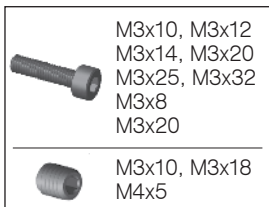

PV0089
SCREW BAG(6 PCS EACH)
內六角螺絲組

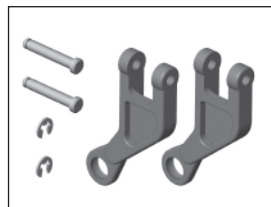

PV0115-1
WASHOUT LINKAGE
連接座

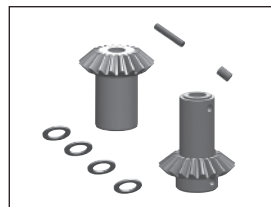

PV0149-1
TAIL GEAR, X50
尾齒輪, X50

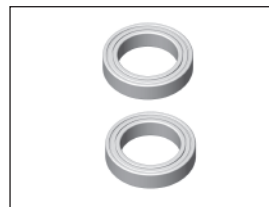

PV0197
BALL BEARING, d12xD18xW4
滾珠軸承組, d12xD18xW4

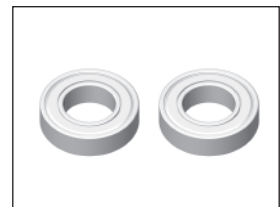

PV0244
BALL BEARING, d10xD19xW5
滾珠軸承組, d10xD19xW5

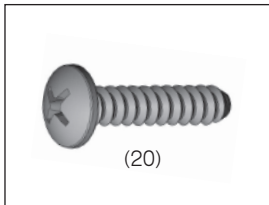

PV0261
SELF TAPPING SCREW (M2.6x14)
扁圓型自攻螺絲組 (M2.6x14)



PV0268
LOCTITE #262
高強度防鬆劑 (紅)



PV0270
THRUST BEARING GREASE
止推軸承潤滑脂



PV0311
HEADER TANK, 60CC
副油箱零件包, 60CC



PV0312
HEADER TANK SUPPORT
副油箱固定座



PV0359
CLUTCH
離合器組



PV0360
STARTER SHAFT
啟動軸

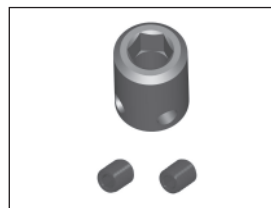

PV0361
STARTER COUPLING
啟動接頭

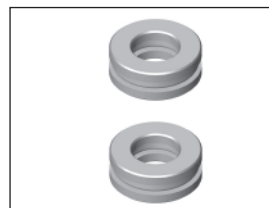

PV0365
THRUST BRG, d6xD12xW4.5
止推軸承組 d6xD12xW4.5



PV0372
THRUST COLLAR
止推墊片

SPARE PARTS / 零件包

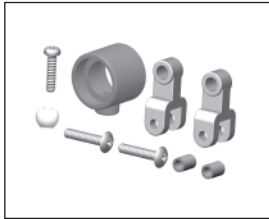

PV0407
TAIL PITCH SLIDER
尾旋翼滑座



PV0450
SUS FLYBAR ROD
SUS平衡桿零件包

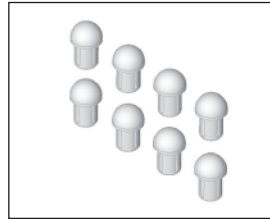

PV0454
SKID PIPE END CAP
圓管塞

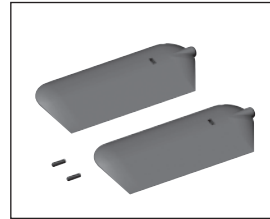

PV0482-L
ULTRA LIGHT PADDLE(BLUE), 20g
超輕量穩定翼(藍色), 20g

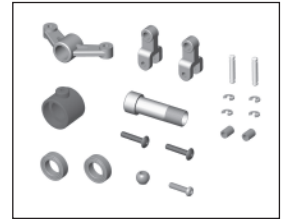

PV0504
TAIL PITCH SLIDER SET
尾旋翼滑座組



PV0512-W
SKID DAMPER (WHITE)
腳架墊圈(螢光白)



PV0523-1
CARBON TAIL BOOM
碳纖維尾管

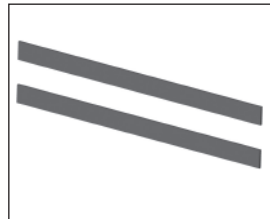

PV0532-1
CLUTCH LINER
離合器片



PV0665
ELEVATOR A ARM
升降舵A臂



PV0671-1
CLUTCH BELL SET
離合器罩組

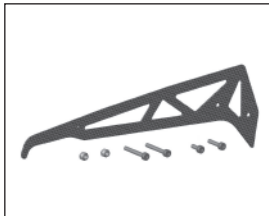

PV0678-1
CARBON VERTICAL FIN
碳纖維垂直安定面

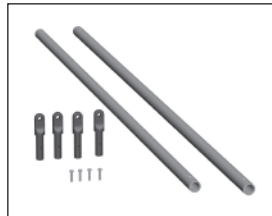

PV0679-T
TAIL SUPPORT
尾管支撐架組



PV0681
MAIN HUB BOLT
主旋翼頭固定螺絲



PV0682
MAIN SHAFT BOLT
主軸齒輪固定螺絲



PV0769
THRUST BEARING, d4xD9xW4
止推軸承組, d4xD9xW4

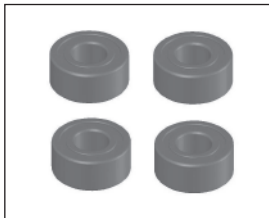

PV0771
BEARING, d4xD9xW4
滾珠軸承組, d4xD9xW4

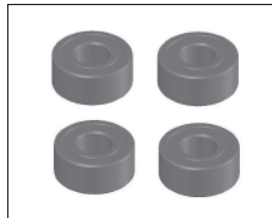

PV0919
BEARING, d3xD6xW2.5
軸承, d3xD6xW2.5

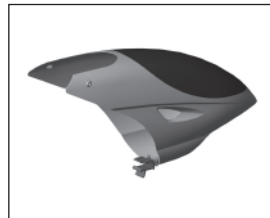

PV1310-L
X50 FRP Canopy (Blue)
X50玻纖維機頭罩 (藍色)

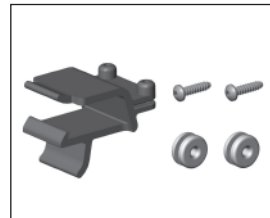

PV1310-1
CANOPY BRACKET, X50
機殼固定座, X50

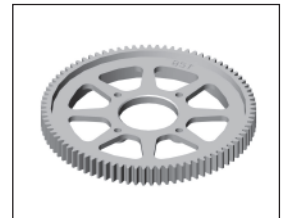

PV1311
MAIN GEAR, 85T
主齒輪盤, 85T



PV1312
FLYBAR JOINT BALL LINK
穩定翼連接桿組



PV1313
120° CONTROL ARM
120° 控制搖臂

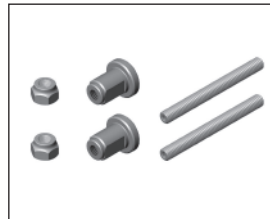

PV1313-1
ARM COLLAR
擺臂固定軸環



PV1314
ELEVATOR ARM SET
升降舵控制組



PV1314-1
METAL ELEVATOR WASHER MOUNT SET(L)
金屬升降舵墊片座組(左)



PV1314-2
METAL ELEVATOR WASHER MOUNT SET(R)
金屬升降舵墊片座組(右)

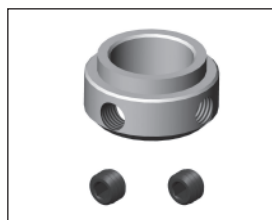

PV1315
MAIN SHAFT LOCK RING
主軸止檔圈

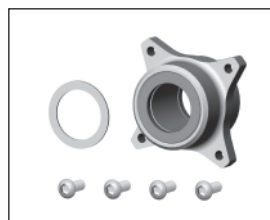

PV1316
ONE WAY CLUTCH HOUSING
單向離合器組

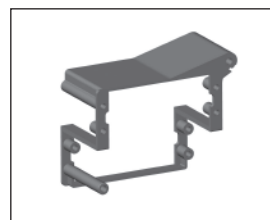

PV1317
CYCLIC SERVO TRAY
循環螺距伺服機座

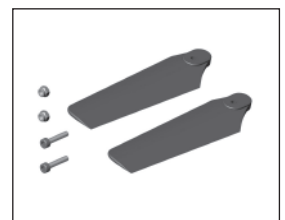

PV1318
TAIL BLADE SET (BLACK)
尾旋翼組(黑)

SPARE PARTS / 零件包



PV1319
DOUBLE LINK
雙頭連接桿

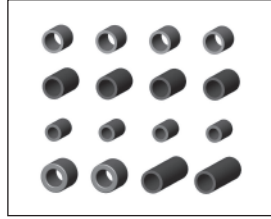

PV1320
COLLAR SET
軸環組

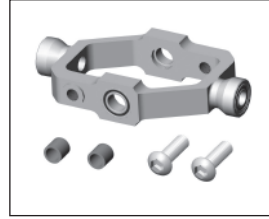

PV1321
METAL SEESAW HUB
金屬穩定桿固定座



PV1322
METAL MIXING LEVER
金屬混控臂



PV1323
METAL HEAD BUTTON
金屬旋翼頭制動器



PV1324
METAL MAIN ROTOR HUB
金屬主旋翼固定座

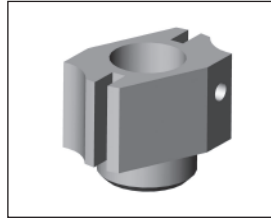

PV1325
METAL WASHOUT BASE
金屬控制臂座

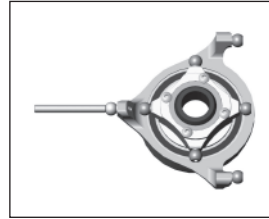

PV1326
METAL SWASHPLATE SET
金屬十字盤組

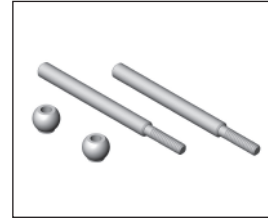

PV1327
SWASHPLATE CONTROL ROD
十字盤穩定桿

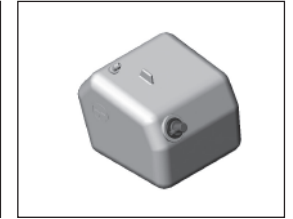

PV1328
FUEL TANK SET
油箱組

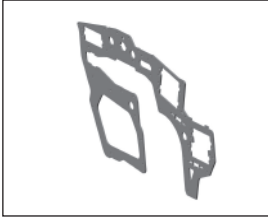

PV1329
CARBON FRAME
機身側板

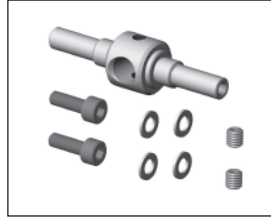

PV1330
METAL TAIL ROTOR HUB
金屬尾旋翼固定座

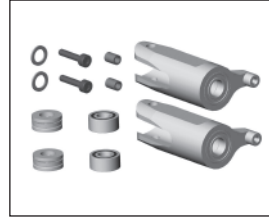

PV1331-1
METAL TAIL GRIP, X50
金屬尾旋翼座(軸傳), X50



PV1332
THROTTLE SERVO TRAY
油門伺服機座



PV1334
HARDENED MAIN SHAFT
強化主軸

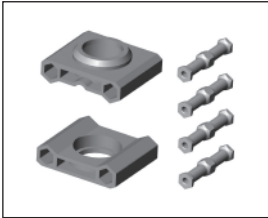

PV1335
MAIN SHAFT BEARING BLOCK
主軸上下軸承座

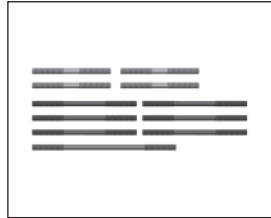

PV1336
LINKAGE ROD SET
連接桿組

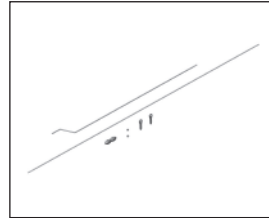

PV1337
TAIL CONTROL ROD
尾推拉桿

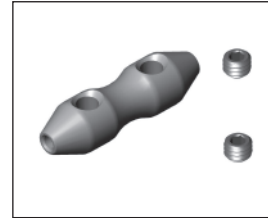

PV1338
TAIL CONTROL ROD JOINT
尾控制桿軸環

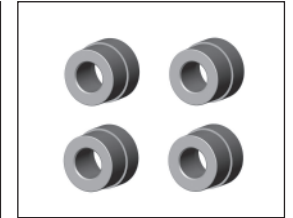

PV1339
OUTER DAMPER(7mm)
外避震墊圈(7mm)

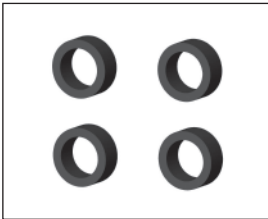

PV1339-1
INNER DAMPER(7mm)
內避震墊圈(7mm)

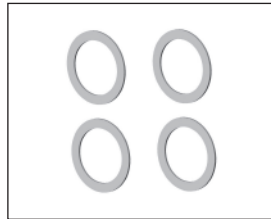

PV1340
MAIN GEAR WASHER
主齒輪墊片

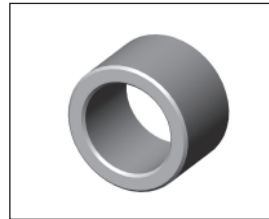

PV1341-1
MAIN GEAR COLLAR-X50
主齒輪組軸環-X50

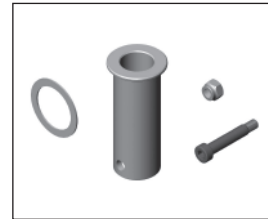

PV1342
ONE WAY CLUTCH SHAFT
單向離合器軸組

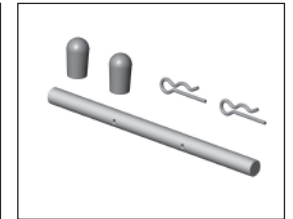

PV1343
CANOPY SPACER
機殼防震支柱

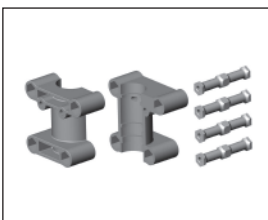

PV1344
CLUTCH BEARING BLOCK
啟動桿軸承固定座



PV1345
PHASING CONTROL TRACK
相位控制導軌

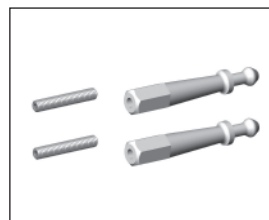

PV1346
CANOPY RETAINING POST
機殼固定鋁柱

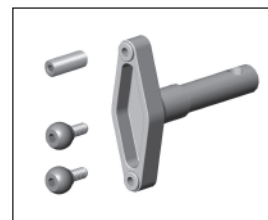

PV1348
METAL ELEVATOR LEVER ROD
金屬升降舵推拉桿

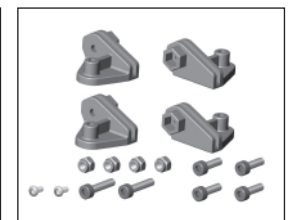

PV1349
PLATE MOUNTING BLOCK
底盤固定座

SPARE PARTS / 零件包

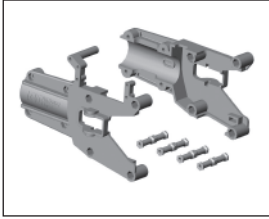

PV1350
TAIL BOOM BRACKET
尾管固定座



PV1351
ROD GUIDE MOUNTING BLOCK
尾拉杆座

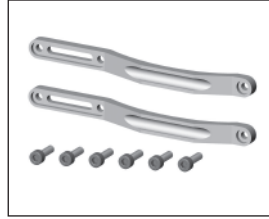

PV1352
METAL MOUNTING BLOCK
金屬側板補強肋

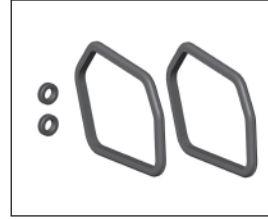

PV1353
TANK RUBBER GROMMETS
油箱保護膠套

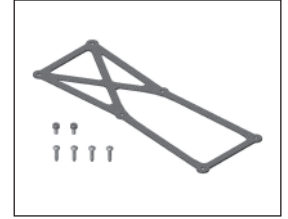

PV1354
CARBON BOTTOM FRAME
碳纖維底座

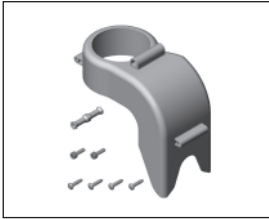

PV1355
COOLING FAN CASING
風扇罩



PV1356
BLADE SUPPORT
主旋翼固定架

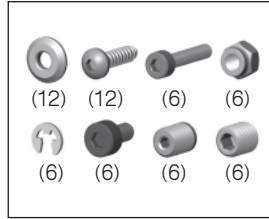

PV1357
SCREW BAG
螺絲零件包

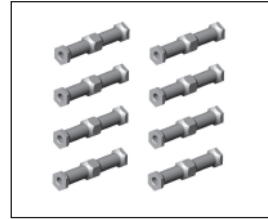

PV1358
FRAME SPACER
六角連接支柱



PV1359
ENGINE MOUNT, X50
引擎固定座, X50

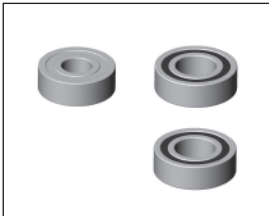

PV1360
STARTER SHAFT BEARINGS
啟動棒軸承組, X50

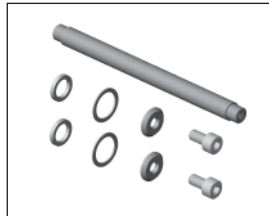

PV1361
SPINDLE (7mm) SET, X50
固定軸 (7mm) 組, X50

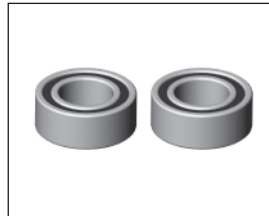

PV1362
SPINDLE (7mm) BRG. SET d7xD13xW5
固定軸 (7mm) 軸承組, d7xD13xW5

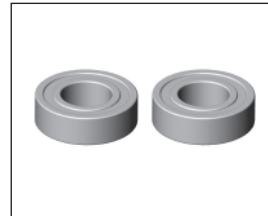

PV1363
TAIL GRIP BAG, d7xD10xW3
尾旋翼座軸承組, d7xD10xW3



PV1364
10T PINION GEAR
10T 驅動齒輪

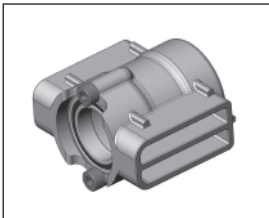

PV1366
TAIL GEAR MOUNT SET
傘齒輪固定座



PV1367
TAIL PITCH CONTROL LEVER SET
尾旋翼控制桿組



PV1368
BEARING BLOCK SET
軸傳軸承座組



PV1369
TAIL DRIVE GEAR SHAFT
軸傳驅動軸

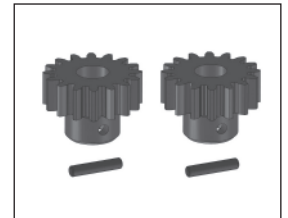

PV1370
TAIL DRIVE GEAR-16T SET
軸傳尾驅動輪 16T

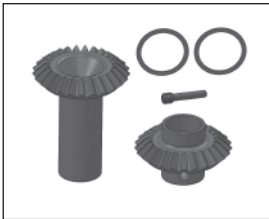

PV1371
TAIL GEAR SET
傘齒輪-25T



PV1372
METAL TAIL UNIT HOUSING SET
金屬尾座



PV1373
AUTOROTATION TAIL DRIVE PULLEY (80T)
軸傳尾驅動主齒-80T



PV1374
LENGTHENED RECEIVER TRAY
加長型接收機座

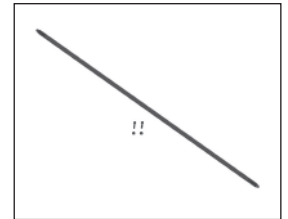

PV1375
TAIL DRIVE SHAFT SET
尾驅動軸組



PV1376
TAIL DRIVE SHAFT BRG SET
傳動軸軸承套組

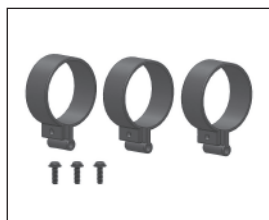

PV1377
ROD GUIDE
固定環

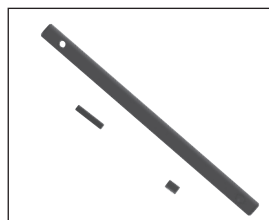

PV1378
TAIL ROTOR SHAFT
尾旋翼橫軸組 (軸傳)

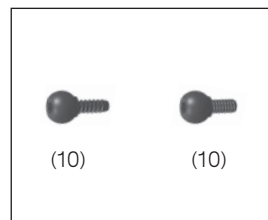

PV1379
LINKAGE BALL SCREW SET
球頭螺絲組



PV1401
METAL MAIN ROTOR GRIP SET
金屬旋翼轉座組

SPARE PARTS / 零件包

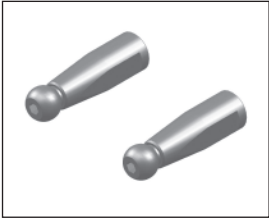

PV1402
METAL MAIN ROTOR GRIP POST
金屬旋翼轉座支柱

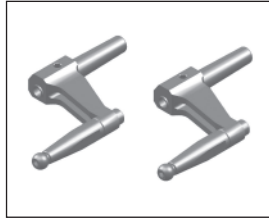

PV1403
METAL FLYBAR CONTROL ARM
金屬穩定翼轉臂組

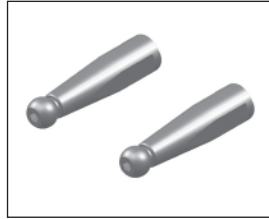

PV1404
METAL FLYBAR CONTROL ARM POST
金屬穩定翼轉臂支柱

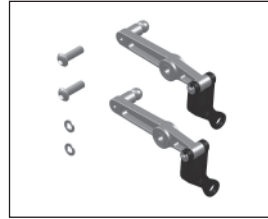

PV1405
METAL FLYBAR CONTROL LEVER
金屬穩定翼控制臂組

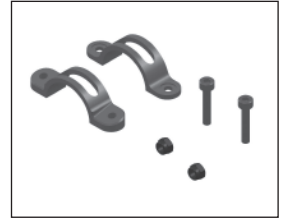

PV1415
METAL TAIL SUPPORT BRACKET
金屬尾支撐桿固定座



PV1417
METAL ROTOR GRIP LEVER
金屬轉座擺臂



PV1418
METAL MAIN ROTOR GRIP
金屬旋翼轉座(本體)

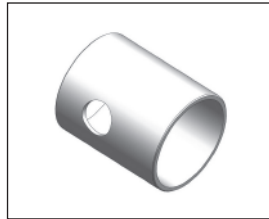

PV1380
TAIL UNIT LINING
尾座內襯

SPARE PARTS LIST / 維修零件包表格



No.	Description	中文名稱	Part No.	Description	中文名稱	Qty	Index Page
1179	SILICONE FUEL LINE,2ft	耐熱油管(透明),2ft	CB0362	FUEL TUBE, d2.5x1.5x ø5.5mm	耐熱油管(透明), d2.5x1.5x ø5.5mm	1	29
3878	TT V2 CARBON BLADE 600mm	碳纖維主旋翼600mm	BV6033	TT V2 CARBON BLADE 600mm	碳纖維主旋翼600mm	1	30
AV0143	COOLING FAN	冷卻風扇	BV0143	COOLING FAN	冷卻風扇	1	15
PV0035-2	LANDING SKID SET	腳架組	BK2261	LANDING SKID	腳架	2	19
			BK0064T	SKID PIPE	底座圓管	2	19
			BK0065	SKID PIPE END CAP	圓管塞	4	19
			HME4-5B	SET SCREW, M4x5	無頭內六角螺絲, M4x5	4	19
			HMC3-14B	SOCKET SCREW, M3x14	內六角螺絲, M3x14	4	19
PV0035-3	LANDING SKID	腳架	BK2261	LANDING SKID	腳架	2	19
			HME4-5B	SET SCREW, M4x5	無頭內六角螺絲, M4x5	4	19
			HMC3-14B	SOCKET SCREW, M3x14	內六角螺絲, M3x14	4	19
PV0041	BALL LINK	單頭連接桿	BK0086	BALL LINK	單頭連接桿	12	12,28
PV0050	BEARING SET	軸承組	HMV1350ZZY	BALL BEARING, d5xD13xW4	滾珠軸承, d5xD13xW4	2	25
PV0051	LEAVER BRG	軸承組	HMV740ZZY	BEARING, d4xD7xW2.5	滾珠軸承, d4xD7xW2.5	4	11,23,25
PV0052	TAIL SLIDER BRG	軸承組	HMV1060ZZY	BEARING, d6xD10xW3	滾珠軸承, d6xD10xW3	2	24
PV0053	ROTOR BOLT	主旋翼螺絲組	HMC4-27B	CAP SCREW, M4x27	內六角螺絲, M4x27	2	30
			HMM4Z	LOCK NUT, M4	止鬆螺帽, M4	2	30
PV0054	SERVO MOUNTING PLATE	伺服機固定片組	BK0104	SERVO MOUNTING PLATE	伺服機固定片	10	27
PV0058	LINKAGE BALL	連接頭	BK0075	LINKAGE BALL	連接頭	12	17,24
PV0060	INSTALLATION SET	組合附件包	BE1052	ANTENNA TUBE	油門拉桿導管	1	-
			BK0106	DOUBLE SIDE TAPE	雙面膠布	2	-
			BK0109	RUBBER BAND, 5x3 20xT1	耐熱橡皮圈, 5x3 20xT1	2	-
			HNI15	HEX WRENCH 1.5m/m	六角扳手	1	-
			HNI2	HEX WRENCH 2m/m	六角扳手	1	-
			HNI25	HEX WRENCH 2.5m/m	六角扳手	1	-
			HNI3	HEX WRENCH 3m/m	六角扳手	1	-
			HNJ-1	TIE BAND 2.5x100	固定束帶	3	-
PV0062	RUBBER GROMMETS(WHITE)	機身固定墊圈組	BK1012	BODY MOUNT RUBBER	機身固定墊圈	5	29
PV0088	SCREW BAG(6 PCS EACH)	圓頭十字螺絲組	HMF2-6N	SCREW, M2x6	圓頭十字螺絲, M2x6	6	-
			HMF2-8N	SCREW, M2x8	圓頭十字螺絲, M2x8	6	-
			HMJ2-10N	SELFTAPPING SCREW, M2x10	自攻螺絲, M2x10	6	-
			HMJ2-14N	SELFTAPPING SCREW, M2x14	自攻螺絲, M2x14	6	-
			HMJ2-6B	SELFTAPPING SCREW, M2x6	圓頭十字自攻螺絲, M2x6	6	-
			HMJ3-22B	SELFTAPPING SCREW, M3x22	自攻螺絲, M3x22	6	-
			HSE2-10B	SELFTAPPING SCREW, M2x10	扁圓型自攻螺絲, M2x10	6	-
			HSE2612N	SELFTAPPING SCREW, M2.6x12	扁圓型自攻螺絲, M2.6x12	6	-
			HSE3-12B	SELFTAPPING SCREW, M3x12	扁圓型自攻螺絲, M3x12	6	-
			HSE3-18B	SELFTAPPING SCREW, M3x18	扁圓型自攻螺絲, M3x18	6	-
			HSE3-5B	SELFTAPPING SCREW, M3x5	扁圓型自攻螺絲, M3x5	6	-
PV0089	SCREW BAG(6 PCS EACH)	內六角螺絲組	BK0616	SOCKET SCREW, M3x20	內六角螺絲(半牙), M3x20	2	-
			HMC3-10B	SOCKET SCREW, M3x10	內六角螺絲, M3x10	6	-
			HMC3-12B	SOCKET SCREW, M3x12	內六角螺絲, M3x12	6	-
			HMC3-14B	SOCKET SCREW, M3x14	內六角螺絲, M3x14	6	-
			HMC3-20B	SOCKET SCREW, M3x20	內六角螺絲, M3x20	4	-
			HMC3-25B	SOCKET SCREW, M3x25	內六角螺絲, M3x25	6	-
			HMC3-32B	SOCKET SCREW, M3x32	內六角螺絲, M3x32	6	-
			HMC3-8B	SOCKET SCREW, M3x8	內六角螺絲, M3x8	6	-
			HME3-10B	SET SCREW, M3x10	無頭內六角螺絲, M3x10	6	-
			HME3-18B	SET SCREW, M3x18	無頭內六角螺絲, M3x18	6	-
			HME4-5B	SET SCREW, M4x5	無頭內六角螺絲, M4x5	6	-

SPARE PARTS LIST / 維修零件包表格



No.	Description	中文名稱	Part No.	Description	中文名稱	Qty	Index Page
PV0115-1	WASHOUT LINKAGE	連接座	BK0016-1	WASHOUT LINKAGE	連接座	2	11
			BK0171	PIN	插銷	2	11
			HMS15	E RING	E 型扣環	2	11
PV0149-1	TAIL GEAR,X50	尾齒輪,X50	BA1144-1	WASHER(d5xD8xW0.15)	軸承墊片, d5xD8xW0.15	4	25
			BK0372	Tail Input Gear	尾齒輪/INPUT-20T	1	25
			BK0373-1	Tail Output Gear	尾齒輪/OUTPUT-20T	1	25
			BD7143	FIXED SCREW	傳動軸固定螺絲(長)	1	25
PV0197	BALL BEARING, d12xD18xW4	滾珠軸承組	HMV6701ZZY	BALL BEARING, d12xD18xW4	滾珠軸承組,d12xD18xW4	1	25
PV0244	BALL BEARING, d10xD19xW5	滾珠軸承組	HMV6800ZZY	BALL BEARING, d10xD19xW5	滾珠軸承組, d10xD19xW5	2	15
PV0261	SELF TAPPING SCREW (M2.6x14)	扁圓型自攻螺絲組	HSE2614N	BUTTON PHILLIPS TAPPING SCREW , M2.6x14	扁圓型自攻螺絲組(粗) , M2.6x14	20	27
PV0268	LOCTITE #262	高強度防鬆劑(#262/紅色)	BV0450	LOCTITE #262	高強度防鬆劑(#262/紅色)	1	-
PV0270	THRUST BEARING GREASE	止推軸承潤滑脂	BV0452	THRUST BEARING GREASE	止推軸承潤滑脂	1	-
PV0311	HEADER TANK, 60CC	副油箱零件包, 60CC	BK0087	WASHER	墊圈	1	22
			BK0102	RUBBER GROMMER	機身固定墊圈	1	22
			BK0506	HEADER TANK SUPPORT	副油箱固定座	1	22
			BV0502	HEADER TANK	副油箱組	1	22
			HMC3-14B	SOCKET SCREW, M3x14	內六角螺絲, M3x14	1	22
PV0312	HEADER TANK SUPPORT	副油箱固定座	BK0087	WASHER	墊圈	1	22
			BK1012	RUBBER GROMMER	機身固定墊圈	1	22
			BK0506	HEADER TANK SUPPORT	副油箱固定座	1	22
			HMC3-14B	SOCKET SCREW, M3x14	內六角螺絲, M3x14	1	22
PV0359	CLUTCH	離合器組	BK0170	SHIM	離合器墊片	1	17
			BV0589	CLUTCH SHOE	離合器組	1	17
			HMC3-10B	SOCKET SCREW, M3x10	內六角螺絲, M3x10	2	17
PV0360	STARTER SHAFT	啟動軸	BK0592	STARTER SHAFT	啟動軸	1	15
			HME4-5B	SET SCREW, M4x5	無頭內六角螺絲, M4x5	2	15
			HMS5	E-CLIP, 5m/m	E 型扣環, 5m/m	1	15
PV0361	STARTER COUPLING	啟動接頭	BK0594	STARTOR COUPLING	啟動接頭	1	15
			HME4-5B	SET SCREW, M4x5	無頭內六角螺絲, M4x5	2	15
PV0365	THRUST BRG. d6xD12xW4.5	止推軸承組 d6xD12xW4.5	HMX0612	THRUST BEARING	止推軸承組	2	10
PV0372	THRUST COLLAR	止推墊片	BK0584	THRUST COLLAR	止推墊片	2	15
PV0407	TAIL PITCH SLIDER	尾旋翼滑座	BK0026	TAIL PITCH CONTROL LINK	尾旋翼連接頭	2	24
			BK0027	TAIL PITCH CONTROL SLIDER	尾旋翼控制滑座	1	24
			BK0075	LINKAGE BALL	連接頭	1	24
			BK0082	COLLAR, d2xD3xW4.3	軸環, d2xD3xW4.3	2	24
			HMJ2-8N	SCREW, M2x8	自攻螺絲(粗), M2x8	1	-
			HSE2-10B	SELF TAPPING SCREW, M2x10	扁圓自攻螺絲(細), M2x10	2	-
PV0450	SUS FLYBAR ROD	SUS平衡桿零件包	BK0631	SUS FLYBAR	SUS 平衡桿	1	9
PV0454	SKID PIPE END CAP	圓管塞	BK0065	SKID PIPE END CAP	圓管	8	19
PV0482-L	ULTRA LIGHT PADDLE(BLUE)	超輕量穩定翼(藍色)	BK0067L	ULTRA LIGHT PADDLE(20G, BLUE)	超輕量穩定翼(20G, 藍色)	2	9
			HME3-10B	SET SCREW, M3x10	無頭內六角螺絲, M3x10	2	9
PV0504	TAIL PITCH SLIDER SET	尾旋翼滑座組	BK0025	TAIL PITCH CONTROL FORK	尾旋翼控制座	1	24
			BK0026	TAIL PITCH CONTROL LINKAGE	尾旋翼連接頭	2	24
			BK0027	TAIL PITCH CONTROL SLIDER	尾旋翼控制滑座	1	24
			BK0028	TAIL PITCH CONTROL SLIDER BUSHING	尾旋翼控制軸套	1	24
			BK0075	LINKAGE BALL	連接頭	1	24
			BK0082	COLLAR, d2xD3xL4	軸環, d2xD3xL4	2	24
			BK0546	PIN, 2mm	插銷, 2mm	2	-
			HMF2-8N	SCREW, M2x8	圓頭十字螺絲, M2x8	1	24
			HSE2-10B	SELF TAPPING SCREW, M2x8	扁圓自攻螺絲(細), M2x8	2	24

SPARE PARTS LIST / 維修零件包表格



No.	Description	中文名稱	Part No.	Description	中文名稱	Qty	Index Page
PV0115-1	WASHOUT LINKAGE	連接座	BK0016-1	WASHOUT LINKAGE	連接座	2	11
			BK0171	PIN	插銷	2	11
			HMS15	E RING	E 型扣環	2	11
PV0149-1	TAIL GEAR,X50	尾齒輪,X50	BA1144-1	WASHER(d5xD8xW0.15)	軸承墊片, d5xD8xW0.15	4	25
			BK0372	TAIL INPUT GEAR	尾齒輪, INPUT-20T	1	25
			BK0373-2	TAIL OUTPUT GEAR	尾齒輪, OUTPUT-20T	1	25
			HMY2-10	PIN, d2x10	固定銷, d2x10	1	25
			HME3-4B	SET SCREW, M3x4	無頭內六角螺絲, M3x4	1	25
PV0197	BALL BEARING, d12xD18xW4	滾珠軸承組	HMV6701ZZY	BALL BEARING, d12xD18xW4	滾珠軸承組,d12xD18xW4	1	25
PV0244	BALL BEARING, d10xD19xW5	滾珠軸承組	HMV6800ZZY	BALL BEARING, d10xD19xW5	滾珠軸承組, d10xD19xW5	2	15
PV0261	SELFTAPPING SCREW (M2.6x14)	扁圓型自攻螺絲組	HSE2614N	BUTTON PHILLIPS TAPPING SCREW , M2.6x14	扁圓型自攻螺絲組(粗) , M2.6x14	20	27
PV0268	LOCTITE #262	高強度防鬆劑(#262/紅色)	BV0450	LOCTITE #262	高強度防鬆劑(#262/紅色)	1	-
PV0270	THRUST BEARING GREASE	止推軸承潤滑脂	BV0452	THRUST BEARING GREASE	止推軸承潤滑脂	1	-
PV0311	HEADER TANK, 60CC	副油箱零件包, 60CC	BK0087	WASHER	墊圈	1	22
			BK0102	RUBBER GROMMER	機身固定墊圈	1	22
			BK0506	HEADER TANK SUPPORT	副油箱固定座	1	22
			BV0502	HEADER TANK	副油箱組	1	22
			HMC3-14B	SOCKET SCREW, M3x14	內六角螺絲, M3x14	1	22
PV0312	HEADER TANK SUPPORT	副油箱固定座	BK0087	WASHER	墊圈	1	22
			BK1012	RUBBER GROMMER	機身固定墊圈	1	22
			BK0506	HEADER TANK SUPPORT	副油箱固定座	1	22
			HMC3-14B	SOCKET SCREW, M3x14	內六角螺絲, M3x14	1	22
PV0359	CLUTCH	離合器組	BK0170	SHIM	離合器墊片	1	17
			BV0589	CLUTCH SHOE	離合器組	1	17
			HMC3-10B	SOCKET SCREW, M3x10	內六角螺絲, M3x10	2	17
PV0360	STARTER SHAFT	啟動軸	BK0592	STARTER SHAFT	啟動軸	1	15
			HME4-5B	SET SCREW, M4x5	無頭內六角螺絲, M4x5	2	15
			HMS5	E-CLIP, 5m/m	E 型扣環, 5m/m	1	15
PV0361	STARTER COUPLING	啟動接頭	BK0594	STARTOR COUPLING	啟動接頭	1	15
			HME4-5B	SET SCREW, M4x5	無頭內六角螺絲, M4x5	2	15
PV0365	THRUST BRG. d6xD12xW4.5	止推軸承組 d6xD12xW4.5	HMX0612	THRUST BEARING	止推軸承組	2	10
PV0372	THRUST COLLAR	止推墊片	BK0584	THRUST COLLAR	止推墊片	2	15
PV0407	TAIL PITCH SLIDER	尾旋翼滑座	BK0026	TAIL PITCH CONTROL LINK	尾旋翼連接頭	2	24
			BK0027	TAIL PITCH CONTROL SLIDER	尾旋翼控制滑座	1	24
			BK0075	LINKAGE BALL	連接頭	1	24
			BK0082	COLLAR, d2xD3xW4.3	軸環, d2xD3xW4.3	2	24
			HMJ2-8N	SCREW, M2x8	自攻螺絲(粗), M2x8	1	-
			HSE2-10B	SELF TAPPING SCREW, M2x10	扁圓自攻螺絲(細), M2x10	2	-
PV0450	SUS FLYBAR ROD	SUS平衡桿零件包	BK0631	SUS FLYBAR	SUS 平衡桿	1	9
PV0454	SKID PIPE END CAP	圓管塞	BK0065	SKID PIPE END CAP	圓管塞	8	19
PV0482-L	ULTRA LIGHT PADDLE(BLUE)	超輕量穩定翼(藍色)	BK0067L	ULTRA LIGHT PADDLE(20G, BLUE)	超輕量穩定翼(20G, 藍色)	2	9
			HME3-10B	SET SCREW, M3x10	無頭內六角螺絲, M3x10	2	9
PV0504	TAIL PITCH SLIDER SET	尾旋翼滑座組	BK0025	TAIL PITCH CONTROL FORK	尾旋翼控制座	1	24
			BK0026	TAIL PITCH CONTROL LINKAGE	尾旋翼連接頭	2	24
			BK0027	TAIL PITCH CONTROL SLIDER	尾旋翼控制滑座	1	24
			BK0028	TAIL PITCH CONTROL SLIDER BUSHING	尾旋翼控制軸套	1	24
			BK0075	LINKAGE BALL	連接頭	1	24
			BK0082	COLLAR, d2xD3xL4	軸環, d2xD3xL4	2	24
			BK0546	PIN, 2mm	插銷, 2mm	2	-
			HMF2-8N	SCREW, M2x8	圓頭十字螺絲, M2x8	1	24

SPARE PARTS LIST / 維修零件包表格



No.	Description	中文名稱	Part No.	Description	中文名稱	Qty	Index Page
			HSE2-10B	SELFTAPPING SCREW, M2x8	扁圓自攻螺絲 (細), M2x8	2	24
			HMS15	E RING	E 型扣環	4	-
			HMV1060ZZY	BEARING, d6xD10xW3	滾珠軸承, d6xD10xW3	2	24
PV0512-W	SKID DAMPER (WHITE)	腳架墊圈(螢光白)	BK0819W	SKID DAMPER, WHITE	腳架墊圈, 螢光白	4	-
PV0523-1	CARBON TAIL BOOM	碳纖維尾管	BK2556	CARBON TAIL BOOM(663mm)	碳纖維尾管(663mm)	1	25
PV0532-1	CLUTCH LINER	離合器片	BK0887-1	SHIM	離合器墊片	2	15
PV0665	ELEVATOR A ARM	升降舵A臂	BK0023	ELEVATOR CONTROL ARM LINK	升降舵連接座	2	19
			BK0084	PIN	插銷	2	19
PV0671-1	CLUTCH BELL SET	離合器罩組	BV1194-1	CLUTCH BELL SET	離合器罩組	1	15
PV0678-1	CARBON VERTICAL FIN	碳纖維垂直安定面	BK2190	CARBON VERTICAL FIN	碳纖維垂直安定面	1	25
			HMC3-25B	SOCKET SCREW, M3x25	內六角螺絲, M3x25	2	-
			HMM3Z	NYLON NUT, M3	止鬆螺帽, M3	2	25
			HMC3-6B	SOCKET SCREW, M3x6	內六角螺絲, M3x6	1	25
			HMC3-10B	SOCKET SCREW, M3x8	內六角螺絲, M3x8	1	25
PV0679-T	TAIL SUPPORT	尾管支撐架組	BK0447	TAIL SUPPORT ROD END	尾管支撐架接頭	4	26
			BK0524-T	TAIL SUPPORT ROD	尾管支撐架	2	26
			HMJ2-8N	SELFTAPPING SCREW	自攻螺絲 (細), M2x8	4	26
PV0681	MAIN HUB BOLT	主旋翼頭固定螺絲	BK0616	SOCKET SCREW, M3x20	內六角螺絲, M3x20	4	11
			HMM3Z	LOCK NUT, M3	止鬆螺帽, M3	4	11
PV0682	MAIN SHAFT BOLT	主軸齒輪固定螺絲	BK1197	MAIN SHAFT BOLT	凸肩內六角螺絲	2	21
			HMM3Z	LOCK NUT, M3	止鬆螺帽, M3	2	21
PV0769	THRUST BEARING	止推軸承組	HMX0409Y	THRUST BEARING	止推軸承, d4xD9xW4	2	24
PV0771	BEARING	滾珠軸承組	HMV940ZZY	BEARING, d4xD9xW4	滾珠軸承, d4xD9xW4	4	24
PV0919	BEARING	軸承	HMV630ZZY	BEARING, d3xD6xW2.5	軸承, d3xD6xW2.5	4	7
PV1310-L	X50 FRP CANOPY (BLUE)	X50 玻纖機頭罩 (藍)	BK2177-L	FRP CANOPY SET,X50	玻纖機殼組-藍	1	29
			BK0102	RUBBER GROMMET	機身固定墊圈	2	29
			BK2278	CANOPY BRACKET	機殼固定座	1	29
			HNX3-12B	S.B.H SELF TAPPING SCREW	半圓頭內六角自攻螺絲	2	29
PV1310-1	CANOPY BRACKET, X50	機殼固定座, X50	BK0102	RUBBER GROMMET	機身固定墊圈	2	29
			BK2278	CANOPY BRACKET	機殼固定座	1	29
			HNX3-12B	S.B.H SELF TAPPING SCREW	半圓頭內六角自攻螺絲	2	20
PV1311	MAIN GEAR, 85T	主齒輪盤, 85T	BK2285	MAIN GEAR, 85T	主齒輪盤, 85T	1	20
PV1312	FLYBAR JOINT BALL LINK	穩定翼連接桿組	BK2228	FLYBAR JOINT BALL LINK	穩定翼連接桿	4	12
PV1313	120° CONTROL ARM	120° 控制搖臂	BK2160-L	120° CONTROL ARM(L)	120° 控制搖臂(左)	1	23
			BK2160-R	120° CONTROL ARM(R)	120° 控制搖臂(右)	1	23
			BK0649-2	LINKAGE BALL(B)	內六角連接頭自攻螺絲(B)	6	23
			HMV740ZZY	BEARING, d4xD7xW2.5	滾珠軸承, d4xD7xW2.5	4	23
			BK0077	COLLAR, d3xD4xW6	軸環, d3xD4xW6	2	23
PV1313-1	ARM COLLAR	擺臂固定軸環	BK2227	ARM COLLAR	擺臂固定軸環	2	23
			HME3-30B	SET SCREW, M3x30	無頭內六角螺絲, M3x30	2	23
			HMM3Z	NYLON NUT, M3	止鬆螺帽, M3	2	23
PV1314	ELEVATOR ARM SET	升降舵控制組	BK0023	ELEVATOR CONTROL ARM LINK	升降舵連接座	1	19
			BK2514	METAL ELEVATOR CONTROL ARM	金屬升降舵控制臂	1	19
			BK0084	PIN	固定銷	1	19
			HME3-3B	SET SCREW, M3x3	無頭內六角螺絲, M3x3	1	19
			HMC3-10B	SOCKET SCREW, M3x10	內六角螺絲, M3x10	1	19
			BK2515	COLLAR, d3xD5xW4.2	控制臂軸環, d3xD5xW4.2	1	19
			HME3-8B	SET SCREW, M3x8	無頭內六角螺絲, M3x8	1	19
PV1314-1	METAL ELEVATOR WASHER MOUNT SET(L)	金屬升降舵墊片座組(左)	BV2238	ELEVATOR WASHER MOUNT SET(L)	升降舵墊片座組(左)	1	14
			HMC2-4B	SOCKET SCREW, M2x4	內六角螺絲, M2x4	2	14

SPARE PARTS LIST / 維修零件包表格



No.	Description	中文名稱	Part No.	Description	中文名稱	Qty	Index Page
			HMC3-10B	SOCKET SCREW, M3x10	內六角螺絲, M3x10	1	14
			BK2515	COLLAR, d3xD5xW4.2	控制臂軸環, d3xD5xW4.2	1	14
PV1314-2	METAL ELEVATOR WASHER MOUNT SET(R)	金屬升降舵墊片座組(右)	BV2237	ELEVATOR WASHER MOUNT SET(R)	升降舵墊片座組(右)	1	14
			HMC2-4B	SOCKET SCREW, M2x4	內六角螺絲, M2x4	2	14
			HME3-8B	SET SCREW, M3x8	無頭內六角螺絲, M3x8	1	14
PV1315	MAIN SHAFT LOCK RING	主軸止檔圈	BK2206	MAIN SHAFT LOCK RING	止檔圈	1	12
			HME4-3B	SET SCREW, M4x3	無頭內六角螺絲, M4x3	2	12
PV1316	ONE WAY CLUTCH HOUSING	單向離合器組	BV2281	ONE WAY CLUTCH HOUSING	單向離合組	1	20
			HSA3-8	BUTTON HEAD SOCKET SCREW, M3x8	半圓頭內六角螺絲, M3x8	4	20
			BK2524	MAIN GEAR WASHER	主齒輪墊片	1	20
PV1317	CYCLIC SERVO TRAY	循環螺距伺服機座	BK2259	SERVO FRAME B	伺服機座B	1	16
PV1318	TAIL BLADE SET (BLACK)	尾旋翼組(黑)	BK0404-B	TAIL BLADE(BLACK)	尾旋翼(黑)	2	25
			HMC3-16B	SOCKET SCREW (M3x16)	內六角螺絲(M3x16)	2	25
			HMM3Z	NYLON NUT, M3	止鬆螺帽, M3	2	25
PV1319	DOUBLE LINK	雙頭連接桿	BK2179	DOUBLE LINK	雙頭連接桿	4	12
PV1320	COLLAR SET	軸環組	BK2187	COLLAR, d3xD4xW3.8	軸環, d3xD4xW3.8	4	-
			BK2515	COLLAR, d3xD5xW4.2	控制臂軸環, d3xD5xW4.2	2	-
			BK0077	COLLAR, d3xD4xW6	軸環, d3xD4xW6	4	-
			BK0082	COLLAR, d2xD3xW4.2	軸環, d2xD3xW4.2	4	-
			BK0076	COLLAR, d3xD4xW10	軸環, d3xD4xW10	2	-
PV1321	METAL SEESAW HUB	金屬穩定桿固定座	BV2186	METAL SEESAW HUB	金屬穩定桿固定座	1	7
			BK2187	COLLAR, d3xD4xW3.8	軸環, d3xD4xW3.8	2	7
			HSA3-10	BUTTON HEAD SOCKET SCREW, M3x10	半圓頭內六角螺絲, M3x10	2	7
PV1322	METAL MIXING LEVER	金屬混控臂	BV2183	METAL MIXING LEVER	金屬混控臂	2	8
			BK0649-1	LINKAGE BALL (A)	內六角連接頭螺絲(A)	4	8
			BK0077	COLLAR, d3xD4xW6	軸環, d3xD4xW6	2	8
			HSA3-10	BUTTON HEAD SOCKET SCREW, M3x10	半圓頭內六角螺絲, M3x10	2	8
PV1323	METAL HEAD BUTTON	金屬旋翼頭制動器	BK2182	METAL HEAD BUTTON	金屬旋翼頭制動器	1	7
			HMC25-8B	SOCKET SCREW, M2.5×8	內六角螺絲, M2.5×8	1	7
PV1324	METAL MAIN ROTOR HUB	金屬主旋翼固定座	BV2181	METAL MAIN ROTOR HUB	金屬主旋翼固定座	1	7
			BK2572	INNER DAMPER(7mm)	內避震墊圈(7mm)	2	10
			BK2573	OUTER DAMPER(7mm)	外避震墊圈(7mm)	2	10
			BK0616	SOCKET SCREW, M3x20	內六角螺絲(半牙), M3x20	2	11
			HMM3Z	NYLON NUT, M3	止鬆螺帽, M3	2	11
PV1325	METAL WASHOUT BASE	金屬控制臂座	BK2196	METAL WASHOUT BASE	控制臂座	1	11
PV1326	METAL SWASHPLATE SET	金屬十字盤組	BV2188A	METAL SWASHPLATE	金屬十字盤組	1	11
PV1327	SWASHPLATE CONTROL ROD	十字盤穩定桿	BK2209	SWASHPLATE CONTROL ROD	十字盤穩定桿	2	11
			BK0075	LINKAGE BALL	連接頭	2	11
PV1328	FUEL TANK SET	油箱組	BV2230	FUEL TANK SET	油箱組	1	22
PV1329	CARBON FRAME	機身側板	BK2215	SIDE FRAME	機身側板	1	14
PV1330	METAL TAIL ROTOR HUB	金屬尾旋翼固定座	BK2284	TAIL ROTOR HUB	尾旋翼固定座	1	24
			HME3-3B	SET SCREW, M3x3	無頭內六角螺絲, M3x3	2	24
			HMC25-6B	SOCKET SCREW, M2.5×6	內六角螺絲, M2.5×6	2	24
			HMO26	WASHER, d2.8xD5xW0.5	墊片, d2.8xD5xW0.5	4	24
PV1331-1	METAL TAIL GRIP,X50	金屬尾旋翼座(軸傳),X50	BV2580	METAL TAIL GRIP	金屬尾旋翼座	2	24
			HMX0409Y	THRUST BEARING, d4xD9xW4	止推軸承, d4xD9xW4	2	24
			HMV940ZZY	BEARING, d4xD9xW4	滾珠軸承, d4xD9xW4	2	24
			BK2276	WASHER, d4xD6xW0.5	尾旋翼轉座墊片, d4xD6xW0.5	2	24
			HMC2-10B	SOCKET SCREW, M2×10	內六角螺絲, M2×10	2	24
			BK0082	COLLAR, d2xD3xW4.2	軸環, d2xD3xW4.2	2	24

SPARE PARTS LIST / 維修零件包表格



No.	Description	中文名稱	Part No.	Description	中文名稱	Qty	Index Page
PV1332	THROTTLE SERVO TRAY	油門伺服機座	BK2232	SERVO FRAME A	伺服機座A, 76x65x25	1	16
PV1334	HARDENED MAIN SHAFT	強化主軸	BK2289	HARDENED MAIN SHAFT	強化主軸	1	11
			BK0616	SOCKET SCREW, M3x20	內六角螺絲(半牙), M3x20	2	11
			HMM3Z	NYLON NUT, M3	止鬆螺帽, M3	2	11
PV1335	MAIN SHAFT BEARING BLOCK	主軸上下軸承座	BK2236	UPPER BRG HOUSING	上軸承座	1	12
			BK2225	LOWER BRG HOUSING	下軸承座	1	15
			BK2219	FRAME SPACER	六角連接支柱	4	12,15
PV1336	LINKAGE ROD SET	連接桿組	BK0092	LINKAGE ROD, 30mm	連接桿, 30mm	4	28
			BK2516	LINKAGE ROD, 40mm	連接桿, 40mm	6	12
			BK0436	LINKAGE ROD, 55mm	連接桿, 55mm	1	28
PV1337	TAIL CONTROL ROD	尾推拉桿	BK2195	TAIL SERVO LINKAGE ROD, 345mm	尾伺服機推拉桿, 345mm	1	28
			BK0175	LINKAGE ROD, 575mm	推拉桿, 575mm	1	28
			BK0105-1	TAIL CONTROL ROD JOINT	尾控制桿軸環	1	28
			HME4-3B	SET SCREW, M4x3	無頭內六角螺絲, M4x3	2	28
			BK0086	BALL LINK	單頭連接桿	2	28
PV1338	TAIL CONTROL ROD JOINT	尾控制桿軸環	BK0105-1	TAIL CONTROL ROD JOINT	尾控制桿軸環	1	28
			HME4-3B	SET SCREW, M4x3	無頭內六角螺絲, M4x3	2	28
PV1339	OUTER DAMPER(7mm)	外避震墊圈(7mm)	BK2573	OUTER DAMPER(7mm)	外避震墊圈(7mm)	4	10
PV1339-1	INNER DAMPER(7mm)	內避震墊圈(7mm)	BK2572	INNER DAMPER(7mm)	內避震墊圈(7mm)	4	10
PV1340	MAIN GEAR WASHER	主齒輪墊片	BK2524	MAIN GEAR WASHER	主齒輪墊片	4	20
PV1341-1	MAIN GEAR COLLAR, X50	主齒輪組軸環, X50	BK2290	COLLAR	軸環	1	21
PV1342	ONE WAY CLUTCH SHAFT	單向離合器軸組	BK2282	ONE WAY BEARING SHAFT	單向軸套	1	20
			BK1197	MAIN SHAFT BOLT, M3x20	內六角半牙螺絲, M3x20	1	21
			HMM3Z	NYLON NUT, M3	止鬆螺帽, M3	1	21
			BK2524	MAIN GEAR WASHER	主齒輪墊片	1	20
PV1343	CANOPY SPACER	機殼防震支柱	BK0473-1	CANOPY SPACER	機殼支撐柱	1	22
			BK0474	GROMMET	橡膠帽	2	22
			HNL6	R CLIP	R形插銷	2	22
PV1344	CLUTCH BEARING BLOCK	啟動棒軸承固定座	BK2241-L	CLUTCH BEARING BLOCK(L)	啟動棒軸承固定座(左)	1	15
			BK2241-R	CLUTCH BEARING BLOCK(R)	啟動棒軸承固定座(右)	1	15
			BK2219	FRAME SPACER	六角連接支柱	4	15
PV1345	PHASING CONTROL TRACK	相位控制導軌	BK2248	PHASING CONTROL TRACK	相位控制導軌	1	22
			HME3-18B	SET SCREW, M3x18	無頭內六角螺絲, M3x18	2	22
			HMC2-4B	SOCKET SCREW, M2x4	內六角螺絲, M2x4	2	22
PV1346	CANOPY RETAINING POST	機殼固定鋁柱	BK2249	CANOPY RETAINING POST	機殼固定鋁柱	2	22
			HME3-18B	SET SCREW, M3x18	無頭內六角螺絲, M3x18	2	22
PV1348	METAL ELEVATOR LEVER ROD	金屬升降舵推拉桿	BK2161	ELEVATOR LEVER ROD	升降舵推拉桿	1	19
			HME3-8B	SET SCREW, M3x8	無頭內六角螺絲, M3x8	1	19
			BK0649-1	LINKAGE BALL (A)	內六角連接頭螺絲(A)	2	19
PV1349	PLATE MOUNTING BLOCK	底盤固定座	BK2240-R	PLATE MOUNTING BLOCK(R)	底盤固定座(右)	2	18
			BK2240-L	PLATE MOUNTING BLOCK(L)	底盤固定座(左)	2	18
			HMM3Z	NYLON NUT, M3	止鬆螺帽, M3	4	18
			HMC3-10B	SOCKET SCREW, M3x10	內六角螺絲, M3x10	4	18
			HMC3-14B	SOCKET SCREW, M3x14	內六角螺絲, M3x14	2	26
PV1350	TAIL BOOM BRACKET	尾管固定座	BK2217-L	TAIL BOOM BRACKET(L)	尾管固定座(左)	1	13
			BK2217-R	TAIL BOOM BRACKET(R)	尾管固定座(右)	1	13
			BK2219	FRAME SPACER	六角連接支柱	4	13
			HSA3-6	BUTTON HEAD SOCKET SCREW, M3x6	圓頭內六角螺絲, M3x6	2	13
PV1351	ROD GUIDE MOUNTING BLOCK	尾拉桿座	BK2247	ROD GUIDE MOUNTING BLOCK	尾拉桿座	1	22
			HMC3-14B	SOCKET SCREW, M3x14	內六角螺絲, M3x14	1	22

SPARE PARTS LIST / 維修零件包表格



No.	Description	中文名稱	Part No.	Description	中文名稱	Qty	Index Page
			HMC3-10B	SOCKET SCREW, M3x10	內六角螺絲, M3x10	1	22
PV1352	METAL MOUNTING BLOCK	金屬側板補強肋	BK2229	MOUNTING BLOCK	側板補強肋	2	15,16
			HMC3-10B	SOCKET SCREW, M3x10	內六角螺絲, M3x10	6	15,16
PV1353	TANK RUBBER GROMMETS	油箱保護膠套	BK2246	TANK RUBBER GROMMETS	油箱保護膠套	2	14
			BK0274	RUBBER GROMMETS	橡膠墊圈	2	14
PV1354	CARBON BOTTOM FRAME	碳纖維底盤	BK2234	CARBOM BOTTOM FRAME	碳纖維底盤	1	18
			HMC3-6B	SOCKET SCREW, M3x6)	內六角螺絲, M3x6	2	18
			HMC3-14B	SOCKET SCREW, M3x14	內六角螺絲, M3x14	4	18
PV1355	COOLING FAN CASING	風扇罩	BK2220	COOLING FAN CASING	風扇罩	1	15
			BK2219	FRAME SPACER	六角連接支柱	1	15
			HMC3-10B	SOCKET SCREW, M3x10	內六角螺絲, M3x10	2	15
			HMX3-12B	S.B.H SELF TAPPING SCREW	半圓頭內六角自攻螺絲	4	15
PV1356	BLADE SUPPORT	主旋翼固定架	BK0116-1	BLADE SUPPORT	主旋翼固定架	1	-
PV1357	SCREW BAG	螺絲零件包	BK0087	WASHER d3xD8xW1.4	墊片, d3xD8xW1.4	12	-
			HMX3-12B	S.B.H SELF TAPPING SCREW	半圓頭內六角自攻螺絲	12	-
			HMC2-4B	SOCKET SCREW, M2x4	內六角螺絲, M2x4	6	-
			HME4-5B	SET SCREW, M4x5	無頭內六角螺絲, M4x5	6	-
			HME3-4B	SET SCREW, M3x4	無頭內六角螺絲, M3x4	6	-
			HMS15	E RING	E型扣環	6	-
			HMC3-16B	SOCKET SCREW, M3x16	內六角螺絲, M3x16	6	-
HMM3Z	NYLON NUT, M3	止鬆螺帽, M3	6	-			
PV1358	FRAME SPACER	六角連接支柱	BK2219	FRAME SPACER	六角連接支柱	8	-
PV1359	ENGINE MOUNT,X50	引擎固定座,X50	BK2231	ENGINE MOUNT	引擎固定座, X50	1	17
PV1360	STARTER SHAFT BEARING	啟動棒軸承組,X50	HMV696ZZY	BEARING d6xD15xW5	滾珠軸承, d6xD15xW5	1	15
			HMV1680ZZY	BEARING d8xD16xW5	滾珠軸承, d8xD16xW5	2	15
PV1361	SPINDLE SET(7mm), X50	固定軸組(7mm), X50	BK2214	HARDENED FEATHERING SHAFT	強化固定軸(D7)	1	10
			BK2525	FLAP COLLAR, d7xD10xW1.5	避震軸環, d7xD10xW1.5	2	10
			BK2216	THRUST WASHER, d10xD13xW0.5	止推墊片, d10xD13xW0.5	2	10
			BK0435	WASHER, d4xD11xW1.7	墊圈, d4xD11xW1.7	2	10
			HMC4-8B	SOCKET SCREW, M4x8	內六角螺絲, M4x8	2	10
PV1362	SPINDLE BRG. SET(7mm), d7xD13xW5	固定軸承組(7mm), d7xD13xW5	HMV1370ZZWY	BEARING, d7xD13xW5	滾珠軸承, d7xD13xW5	2	10
PV1363	TAIL GRIP BEARING	尾旋翼座軸承組	HMV1050ZZWY	BEARING, d5xD10xW3	滾珠軸承, d5xD10xW3	2	24
PV1364	PINION GEAR(10T), X50	驅動齒輪(10T), X50	BK0779-1	PINION(10T)	驅動齒(10T)	1	15
PV1366	TAIL GEAR MOUNT SET	傘齒輪固定座	BV2269	TAIL GEAR MOUNT SET	傘齒輪固定座組	1	13
PV1367	TAIL PITCH CONTROL LEVER SET	尾旋翼控制桿組	BK2512	TAIL PITCH CONTROL LEVER	尾旋翼控制桿	1	25
			BK0077	COLLAR, d3xD4xW6	軸環, d3xD4xW6	1	25
			BK0649-2	LINKAGE BALL (B)	內六角連接頭自攻螺絲(B)	1	25
			HMC3-10B	SOCKET SCREW, M3x10	內六角螺絲, M3x10	1	25
			HMV740ZZY	BEARING, d4xD7xW2.5	滾珠軸承, d4xD7xW2.5	2	25
PV1368	BEARING BLOCK SET	軸傳軸承座組	BV2265	BEARING BLOCK SET	軸傳軸承座組	2	13
PV1369	TAIL DRIVE GEAR SHAFT	軸傳驅動軸	BK2266	TAIL DRIVE GEAR SHAFT	軸傳驅動軸	1	13
			BD7143	FIXED SCREW	傳動軸固定螺絲(長)	1	13
			HMY2-10	PIN, d2x10	軸承滾針, d2x10	1	13
PV1370	TAIL DRIVE GEAR-16T SET	軸傳尾驅動輪16T	BK2264	TAIL DRIVE GEAR-16T	軸傳尾驅動輪-16T	2	13
			HMY2-10	PIN, d2x10	軸承滾針, d2x10	2	13
PV1371	TAIL GEAR SET	傘齒輪-25T	BK2267	TAIL GEAR-A	傘齒輪A-25T	1	13
			BK2268	TAIL GEAR-B	傘齒輪B-25T	1	13
			BD7143	FIXED SCREW (L)	傳動軸固定螺絲(長)	1	13
			BK2509	WASHER, d12xD14.5xW0.2	墊片, d12xD14.5xW0.2	2	13
PV1372	METAL TAIL UNIT HOUSING SET	金屬尾座	BK2501	METAL TAIL UNIT HOUSING	金屬尾座	1	25

SPARE PARTS LIST / 維修零件包表格



No.	Description	中文名稱	Part No.	Description	中文名稱	Qty	Index Page
			BK2502	METAL TAIL PITCH CONTROL HOUSING	尾旋翼控制桿座	1	25
			BK2503	TAIL ROTOR CASE BUTTON	尾管固定片	1	25
			BK2291	COLLAR, d15xD18x6.8L	軸環, d15xD18x6.8L	1	25
			HMV1350ZZY	BEARING, d5xD13xW4	滾珠軸承, d5xD13xW4	2	25
			HMV6701ZZY	BEARING, d12xD18xW4	滾珠軸承, d12xD18xW4	2	25
			HMC2-5B	SOCKET SCREW, M2x5	內六角螺絲, M2x5	1	25
			HMC25-8B	SOCKET SCREW, M2.5x8	內六角螺絲, M2.5x8	1	25
			HMC3-6B	SOCKET SCREW, M3x6	內六角螺絲, M3x6	1	25
			HMC3-10B	SOCKET SCREW (M3x10)	內六角螺絲, M3x10	2	25
PV1373	AUTOROTATION TAIL DRIVE PULLEY(80T)	軸傳尾驅動主齒-80T	BK2287	AUTOROTATION TAIL DRIVE PULLEY(80T)	軸傳尾驅動主齒-80T	1	20
			BK1197	MAIN SHAFT BOLT (M3x20)	內六角半牙螺絲, M3x20	1	21
			HMM3Z	NYLON NUT (M3)	止鬆螺帽, M3	1	21
PV1374	LENGTHENED RECEIVER TRAY	加長型接收機座	BK2257	LENGTHENED RECEIVER TRAY	加長型接收機座	1	22
			HMX3-12B	S.B.H SELF TAPPING SCREW M3X12	半圓頭內六角自攻螺絲	4	22
PV1375	TAIL DRIVE SHAFT SET	尾驅動軸組	BV2552	TAIL DRIVE SHAFT SET	尾驅動軸組	1	23
			HMC2512B	SOCKET SCREW (M2.5X12)	內六角螺絲, M2.5x12	2	23
			HMM25Z	NYLON NUT (M2.5)	止鬆螺帽, M2.5	2	23
PV1376	TAIL DRIVE SHAFT BRG SET	傳動軸軸承套組	BK2529	TAIL DRIVE SHAFT BRG	傳動軸軸承套	2	23
			HMV1680ZZY	BEARING	滾珠軸承, d8xD16xW5	2	23
PV1377	ROD GUIDE	固定環	BK2559	ROD GUIDE	固定環	3	25
			HNN2-6B	TAPPING SCREW, M2x6	墊圈自攻螺絲, M2x6	3	25
PV1378	TAIL ROTOR SHAFT	尾旋翼橫軸組(軸傳)	BK2280	TAIL ROTOR SHAFT	尾旋翼橫軸(軸傳)	1	24
			HMY2-10	PIN, d2x10	固定銷, d2x10	1	25
			HME3-4B	SET SCREW, M3x4	無頭內六角螺絲, M3x4	1	25
PV1379	LINKAGE BALL SCREW SET	球頭螺絲組	BK0649-1	LINKAGE BALL SCREW	內六角連接球頭螺絲	10	8,11,19
			BK0649-2	LINKAGE BALL SLEFTAPPING SCREW	內六角連接球頭自攻螺絲	10	9,10,11,23,27
PV1401	METAL MAIN ROTOR GRIP SET	金屬旋翼轉座組	BV2574	METAL MAIN ROTOR GRIP	金屬旋翼轉座組	2	10
			BK2216	THRUST WASHER	止推墊片	2	10
			HMX0612	THRUST BEARING	止推軸承	2	10
			BK2578	METAL ROTOR GRIP POST	金屬旋翼搖臂支柱	2	10
			BK2579	METAL ROTOR GRIP LEVER	金屬轉座擺臂	2	10
			HSA3-6	BUTTON HEAD SOCKET SCREW(M3x6)	圓頭內六角螺絲	4	10
			BK0649-1	LINKAGE BALL(A)	內六角連接頭螺絲	2	10
			HMC3-8B	SOCKET SCREW, M3x8	內六角螺絲	2	10
PV1402	METAL MAIN ROTOR GRIP POST	金屬旋翼轉座支柱	BK2578	METAL ROTOR GRIP POST	金屬旋翼搖臂支柱	2	10
			BK0649-1	LINKAGE BALL(A)	內六角連接頭螺絲	2	10
PV1403	METAL FLYBAR CONTROL ARM	金屬穩定翼轉臂組	BK2184	METAL FLYBAR CONTROL ARM	金屬穩定翼轉臂	2	9
			BK2185	METAL FLYBAR CONTROL ARM POST	金屬穩定翼轉臂支柱	2	9
			BK0649-1	LINKAGE BALL (A)	內六角連接頭螺絲	2	9
			HMC2510B	SOCKET SCREW	內六角螺絲	2	9
			HME4-5B	SET SCREW	無頭內六角螺絲	2	9
PV1404	METAL FLYBAR CONTROL ARM POST	金屬穩定翼轉臂支柱	BK2185	METAL FLYBAR CONTROL ARM POST	金屬穩定翼轉臂支柱	2	9
			BK0649-1	LINKAGE BALL (A)	內六角連接頭螺絲	2	9
PV1405	METAL FLYBAR CONTROL LEVER	金屬穩定翼控制臂組	BV2199	METAL FLYBAR CONTROL LEVER	金屬穩定翼轉臂組	2	11
			BK0077	COLLAR	軸套	2	11
			HSA3-10	BUTTON HEAD SOCKET SCREW	圓頭內六角螺絲	2	11
			BK0088	WASHER	墊片	2	11
PV1415	METAL TAIL SUPPORT BRACKET	金屬尾支撐桿固定座	BK2563	METAL TAIL SUPPORT BRACKET (UPPER)	金屬固定座(上)	1	26
			BK2564	METAL TAIL SUPPORT BRACKET (LOWER)	金屬固定座(下)	1	26
			HMM3Z	SET SCREW	止鬆螺帽	2	26

SPARE PARTS LIST / 維修零件包表格



No.	Description	中文名稱	Part No.	Description	中文名稱	Qty	Index Page
PV1417	METAL ROTOR GRIP LEVER	金屬轉座擺臂	HMC3-16B	SOCKET SCREW	內六角螺絲	2	26
			BK2579	METAL ROTOR GRIP LEVER	金屬轉座擺臂	2	10
PV1418	METAL MAIN ROTOR GRIP	金屬旋翼轉座(本體)	HSA3-6	BUTTON HEAD SOCKET SCREW, M3x6	圓頭內六角螺絲	4	10
			HMC3-8B	SOCKET SCREW, M3×8	內六角螺絲	2	10
			BV2574	METAL MAIN ROTOR GRIP	金屬旋翼轉座組	2	10
PV1380	TAIL UNIT LINING	尾座內襯	BK2216	THRUST WASHER	止推墊片	2	10
			HMX0612	THRUST BEARING	止推軸承	2	10
			BK2527	TAIL UNIT LINING	尾座內襯	1	24

OPTIONAL PARTS / 改裝零件表



1179-B
耐熱油管(黑),2ft
SILICONE FUEL LINE,2ft

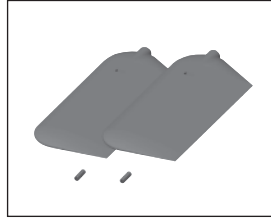

PV0036
PADDLE(BLACK), 30g
穩定翼組(黑), 30g

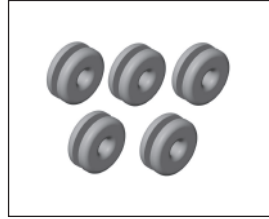

PV0062-Y
RUBBER GROMMETS(YELLOW)
機身固定墊圈組 (黃色)

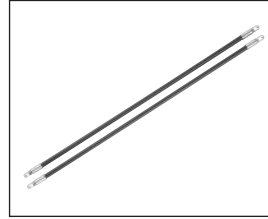

PV0103
Carbon Tail Boom Support
碳纖維尾支撐架組



PV0106
COOLING FAN
金屬冷卻風扇

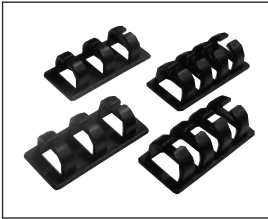

PV0384
WIRE CLAMP
電線整理零件包

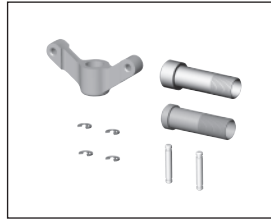

PV0439
METAL TAIL PITCH FORK
尾旋翼控制座

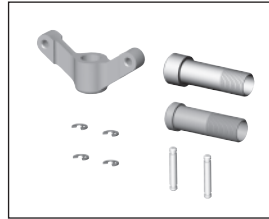

PPV0439-L
METAL TAIL PITCH FORK(BLUE)
尾旋翼控制座(藍)



PV0457
METAL TAIL SLIDER
金屬尾旋翼控制滑座



PV0466
METAL TAIL PITCH FORK
金屬尾旋翼控制座

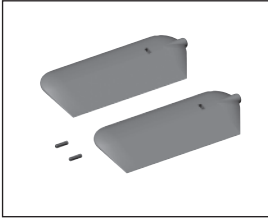

PV0482-R
ULTRA LIGHT PADDLE(RED), 20g
超輕量穩定翼(紅)20g

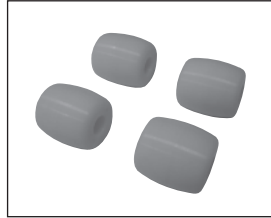

PV0512-Y
SKID DAMPER (YELLOW)
腳架墊圈(黃)

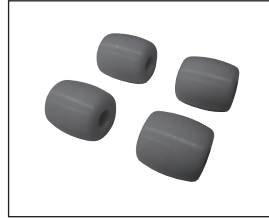

PV0512-L
SKID DAMPER (BLUE)
腳架墊圈(藍)

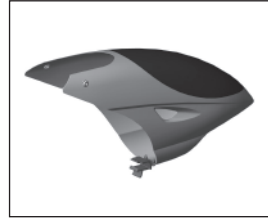

PV1310
X50 FRP CANOPY (RED)
X50玻纖機頭罩 (紅色)

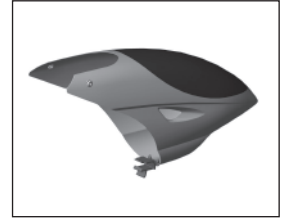

PV1310-W
X50 FRP CANOPY (UNPAINTED WHITE)
X50玻纖機頭罩 (未塗裝白殼)

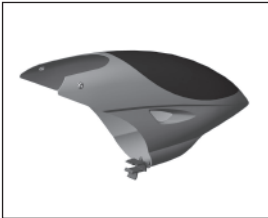

PV1310-Y
X50 FRP CANOPY (YELLOW)
X50玻纖機頭罩 (黃色)

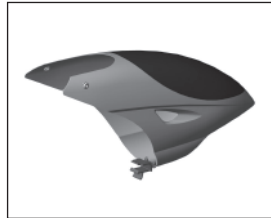

PV1310-G
X50 FRP CANOPY (GREEN)
X50玻纖機頭罩 (綠色)

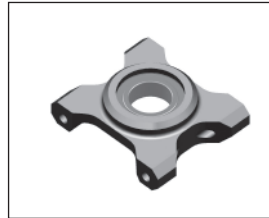

PV1406
METAL UPPER-BRG BLOCK
金屬上軸承座

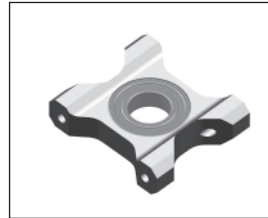

PV1407
METAL LOWER-BRG BLOCK
金屬下軸承座



PV1408
120° METAL CONTROL ARM
120° 金屬控制搖臂



PV1409
140° METAL CONTROL ARM
140° 金屬控制搖臂

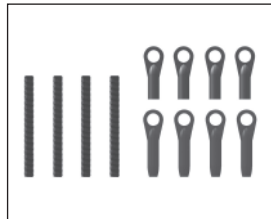

PV1410
140° CONTROL ARM LINKAGE ROD
140° 控制搖臂連接桿

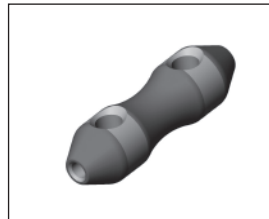

PV1413
TAIL CONTROL ROD JOINT
尾控制桿軸環



PV1414
METAL STABILIZER CONTROL CAGE
金屬穩定翼控制框

MAIN ROTOR HEAD

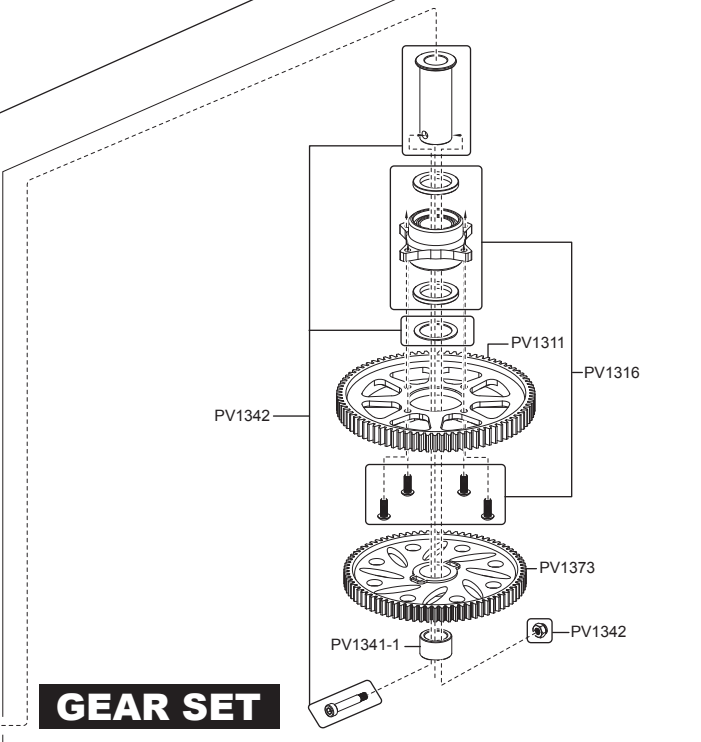
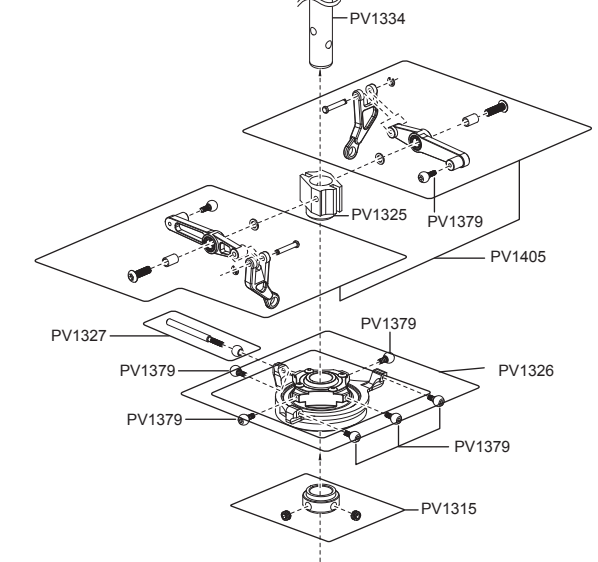
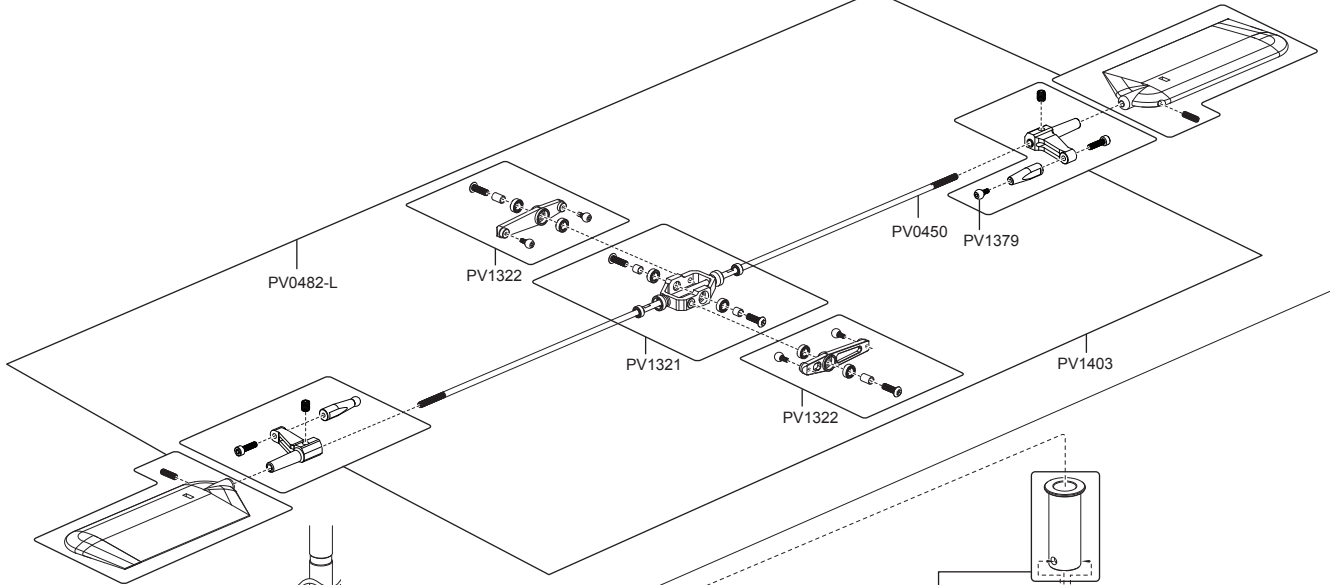
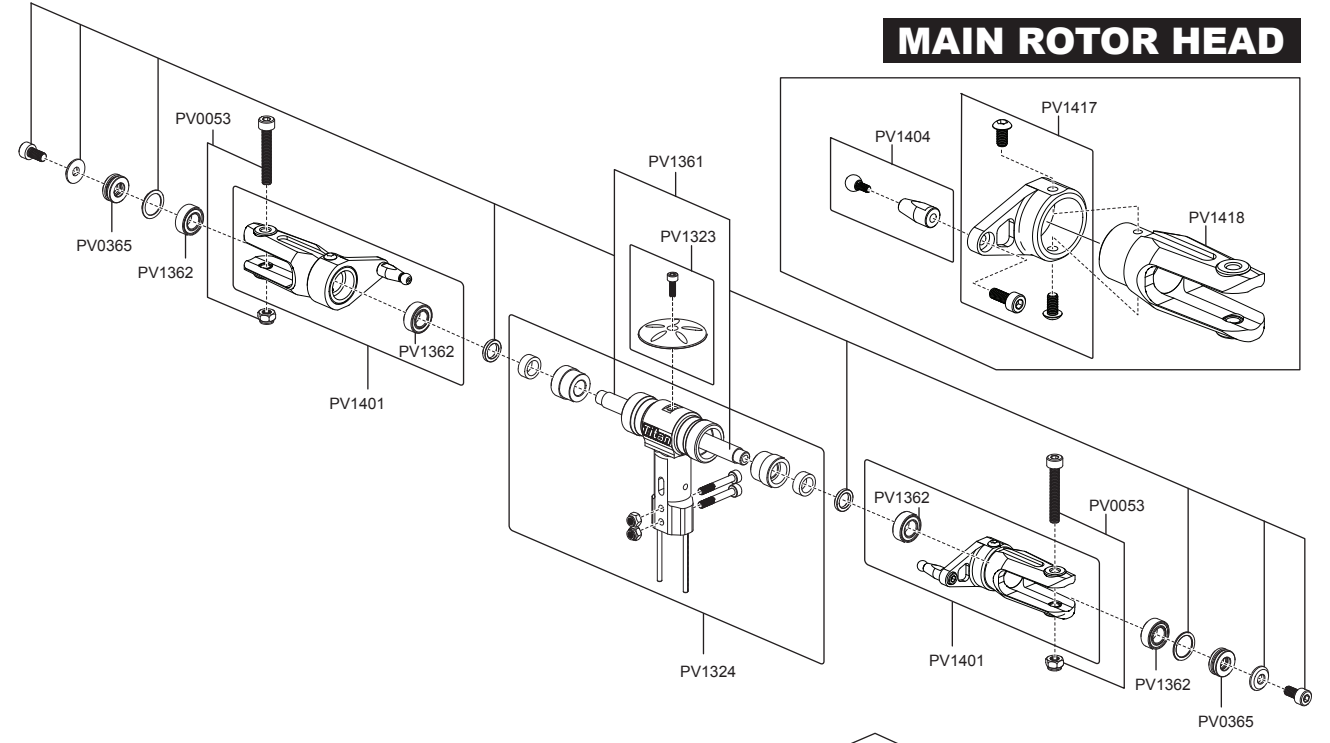

GEAR SET

MAIN FRAME

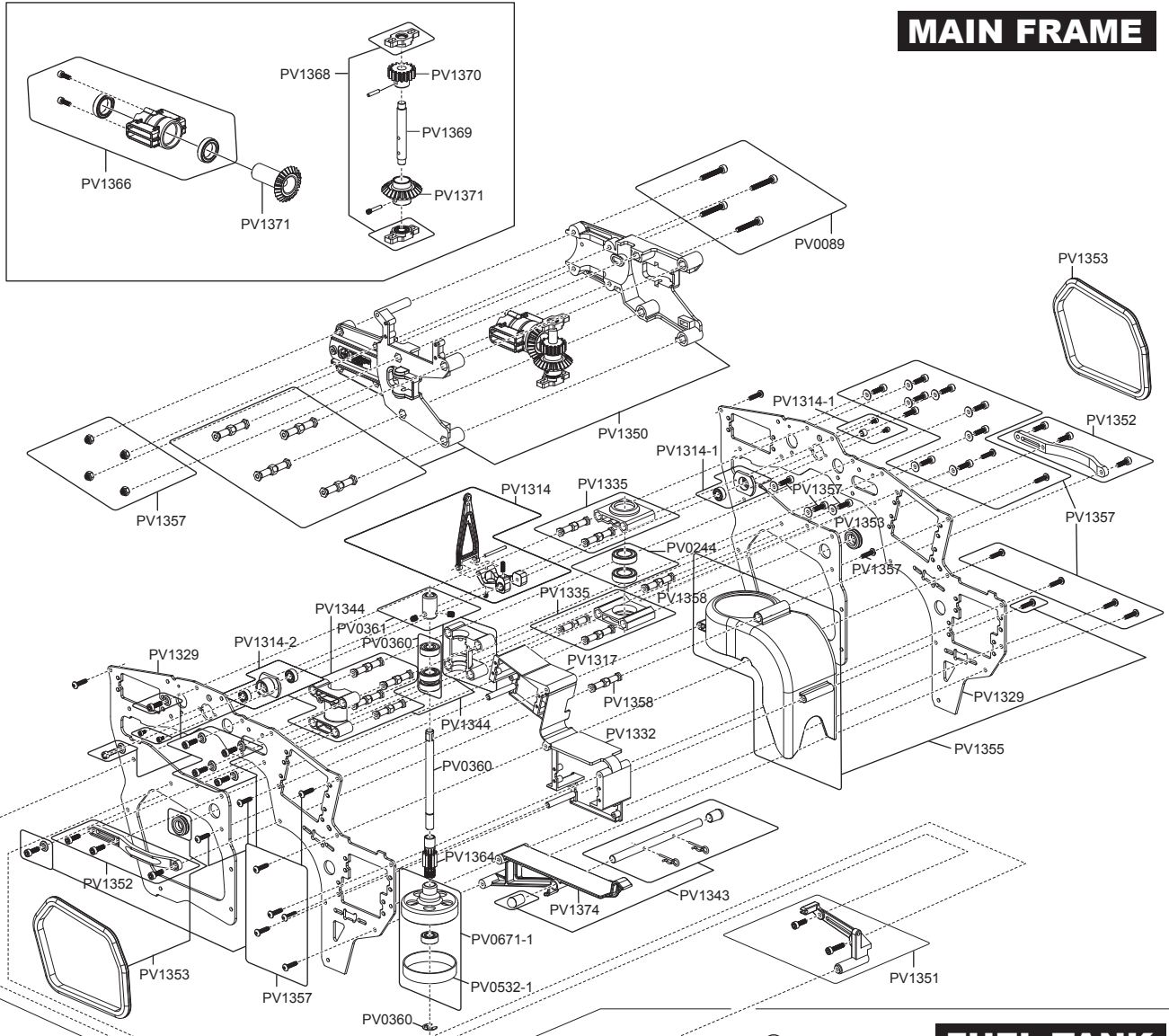

FUEL TANK

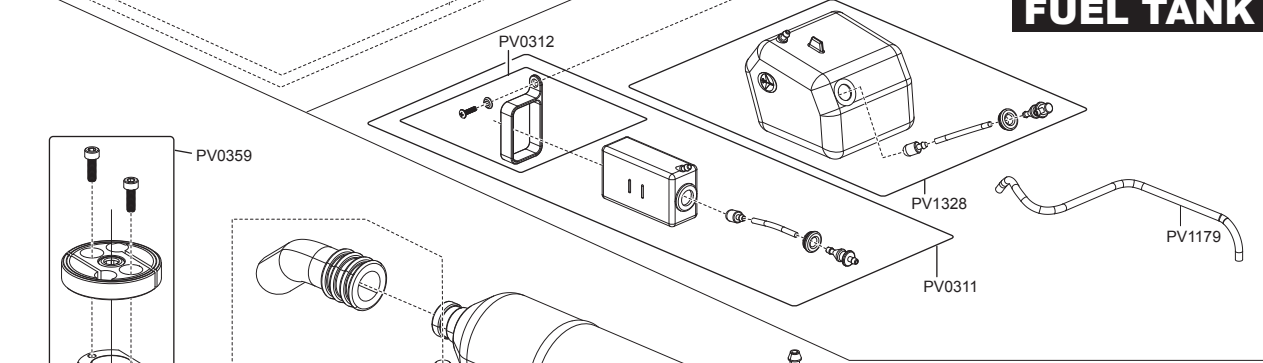

CLUTCH & ENGINE

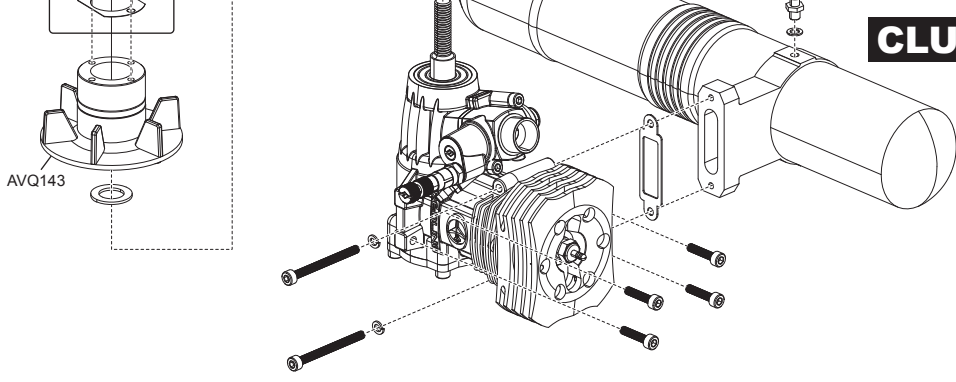

SKID & ENGINE MOUNT

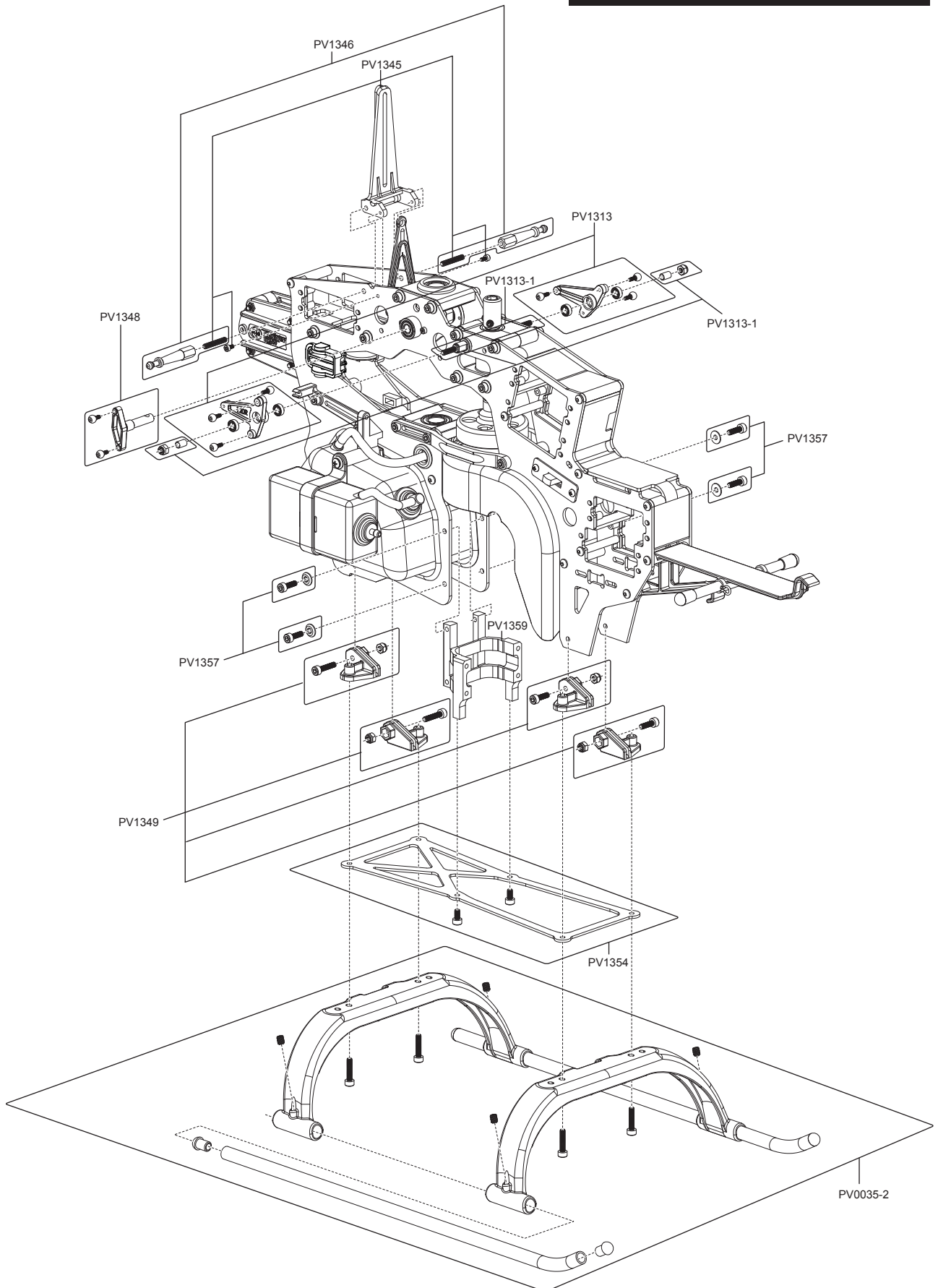

TAIL UNIT

