Voyager™ 50

ASSEMBLY INSTRUCTIONS



SPECIFICATIONS

Overall Length	46.46"	Tail Rotor Diameter	9.17"
Overall Height	16.14"	Gear Ratio	9.78:1:5.18
Main Rotor Diameter	52.64"	Gross Weight	7.5-7.75 lb

INDEX

Section	Description	Page	Section	Description	Page
Introduction		3	5-3	Tail Center Hub Assembly	24
Features		4	5-4	Tail Blade Holder Assembly	24
Items Required to Complete the Voyager 50		4-6	5-5	Tail Pitch Control Lever Installation	25
Hardware Identification		7	5-6	Tail Fin Attachment	25
1-1	Clutch Bell/Start Shaft Assembly	8	5-7	Tail Boom Holder Installation	26
1-2	Tail Drive Pinion/Bearing Block Assembly	8	5-8	Tail Boom Assembly Installation	26
1-3	Elevator Arm Assembly	9	5-9	Tail Boom Brace Assembly	27
1-4	Fuel Tank Assembly	9	5-10	Tail Boom Brace Installation	27
2-1	Upper Main Frame Assembly	10	6-1	Servo Installation	28
2-2	Clutch/Tail Pinion Installation	11	6-2	Tail Control Rod Assembly	29
2-3	Bottom Main Frame Assembly	12	6-3	Tail Control Rod Installation	29
2-4	Fan Cover Stay Installation	13	6-4	Gyro/Receiver/Switch Harness/Battery Installation	30
2-5	Tank Frame Assemble	14		CCPM Software Activation and Initial Adjustment	31-36
2-6	Fuel Tank Installation	14	7-1	Servo Arm Preparation and Installation	37
2-7	Front Radio Bed/Cooling Fan Shroud Installation	15	7-2	CCPM Servo Centering with the Sub-Trim Function	38-39
3-1	Main Drive Gear/Autorotation Assembly	16	7-3	CCPM Linkage Connection	40
3-2	Main Drive Gear/Autorotation Assembly Installation	16	7-4	Checking the Swashplate for Level	41
3-3	Engine Mount Attachment	17	7-5	Pitch-to-Aileron Mixing Adjustment w/Travel Adjust	42
3-4	Landing Gear Assembly Installation	17	7-6	Pitch-to-Elevator Mixing Adjustment w/Travel Adjust	43
3-5	Cooling Fan/Hub Installation	18	7-7	Tail Control Rod Servo Connection	44
3-6	Clutch Assembly Attachment	18	7-8	Throttle Linkage Installation	44
3-7	Engine Installation	19	8-1	Trimming of Body Assembly	45
3-8	Installation of the Muffler	19	8-2	Grommet Attachment	45
4-1	Swashplate Adjustment	20	8-3	Upper Main Frame Section Assembly	46
4-2	Swashplate/Washout Assembly Installation	20	8-4	Main Rotor Blade Attachment	47
4-3	Rotor Head Installation	21		Final Servo Adjustment and Radio Setup	48-50
4-4	Flybar Installation	21		Final Preflight Check	51-59
4-5	Flybar Paddle Attachment	22		Read Through Before Flight	60-62
4-6	Rotor Head/Swash Control Rod Installation	22		Preassembled Components	63-73
5-1	Tail Gear Case Assembly	23		Parts Listings	74-81
5-2	Tail Gear Case Assembly 2	23			

Voyager 50

CCPM

INTRODUCTION

Congratulations on your purchase of the JR Voyager 50 3D CCPM Helicopter kit. The Voyager 50 is based from the popular JR Ergo series of helicopters, taking features like the unique two-piece straight frame design from the latest World Championship JR Vigor™ series.

For years JR has been known for state-of-the-art, high-quality radio control systems known world over for their exceptional reliability and engineering. JR took this reputation and knowledge to the heli market several years ago with the release of the JR Ergo series of helicopters and the development of the now world famous JR Heli Division.

The new JR Voyager 50 is an ideal sport and intermediate 3D model that will provide the user with a very reliable platform, thanks to its reliable belt-driven tail rotor system and parts reducing two-piece straight frame design.

Years in development, the Voyager 50's superior quality and exceptional parts fit and finish create a new standard of precision and quality.

JR CCPM

To take the Voyager design to the next level, JR's designers turned to CCPM (Cyclic/Collective Pitch Mixing). CCPM is a unique control system that mounts three servos below the swashplate with short, straight linkages directly to the swashplate at 120-degree intervals. With CCPM, complex collective and cyclic mixing is accomplished electronically, rather than mechanically. As a result, many parts are eliminated, along with excessive control system play, not to mention quicker building and lower maintenance.

What's more, you get more servo power from CCPM. That's because instead of one servo moving the collective, you now have three. Instead of one servo moving the cyclic, you have two.

Before you begin the assembly of your Voyager CCPM, we suggest that you review the entire instruction manual to become familiar with the assembly sequences and parts layout.

Warning

The radio controlled model helicopter contained in this kit is not a toy, but a sophisticated piece of equipment. This product is not recommended for use by children. Radio controlled models such as this are capable of causing both property damage and/or bodily harm to both the operator/assembler and/or spectator if not properly assembled and operated. Horizon Hobby, Inc. assumes no liability for damage that could occur from the assembly and/or use/misuse of this product.

AMA Information

We strongly encourage all prospective and current R/C aircraft pilots to join the Academy of Model Aeronautics. The AMA is a non-profit organization that provides services to model aircraft pilots. As an AMA member, you will receive a monthly magazine entitled Model Aviation, as well as a liability insurance plan to cover against possible accident or injury. All AMA charter aircraft clubs require individuals to hold a current AMA sporting license prior to operation of their models. For further information, contact the AMA.

Academy of Model Aeronautics
5151 East Memorial Drive
Muncie, IN 47302
(317) 287-1256

Preassembly Information

When first opening your Voyager 50 kit, you will notice that all of the parts are packaged and numbered to coordinate with the assembly step numbers of this instruction manual.

All small hardware (nuts, bolts, washers, etc.) for each step are separated and packaged separately within the main parts bags. When beginning a section, you will need to open only the bag with the corresponding number to the section you are about to start. It is suggested that you place all of the hardware in an open container (e.g., coffee can) during assembly so as not to lose any of the small parts. It may also be helpful to familiarize yourself with the various sizes of screws, bolts, nuts, etc., as illustrated in the appropriate assembly section before you begin assembly. In most cases, at the end of each assembly section there should be no parts remaining.

Great care has been taken in filling the bags with the correct quantity of parts and hardware for each section. However, occasionally mistakes do happen. In the event that you find a parts shortage or are in need of technical assistance, please contact your local JR heli division parts dealer or the Horizon Service Center directly.

Horizon Service Center
4105 Fieldstone Road
Champaign, IL 61822
(217) 355-9511

VOYAGER™ 50 3D CCPM FEATURES

CCPM (Cyclic/Collective Pitch Mixing):

More Accurate: Control system play is totally eliminated
 Simpler: Fewer links to set up and maintain
 More Powerful: Collective has three times the servo power, cyclic has double

Heavy-Duty Mini Vigor/Quad Frame System

Provides excellent rigidity and vibration absorption

One-Way Hex Start Shaft System

Provides positive starting, starter shaft utilizes a one-way bearing that allows the shaft to stop after the engine is started

Wide Spread Tail Output Shaft Bearings

Reduces vibration and improves control response

Belt-Driven Tail Rotor Design

Provides easy adjustment and low maintenance, eliminates the need for optional/expensive tube drive shafts

Precision Ball Bearings at All Critical Locations

Provide low wear, high precision and reduced maintenance

Self-Aligning One-Piece Steel Clutch System

Offers easy installation and adjustment with exceptional reliability

Straight Blade Axle Rotor Head Design

Provides high responsiveness and solid blade tracking

Low Drag Flybar Paddles

Provide quick yet smooth cyclic response at all flight speeds

Heavy-Duty Main Blade Grips with 4mm Blade Bolts

Provide a solid and secure mounting surface to easily handle the stresses of radical 3D flight

Rearward-Facing Engine Design

Provides easy access to the glow plug for starting, engine slips easily through the main frame for trouble-free engine maintenance

Superior Parts Fit and Finish

Make assembly trouble-free and enjoyable

ADDITIONAL ITEMS REQUIRED TO COMPLETE THE HELICOPTER

1. RADIO SYSTEM REQUIREMENTS (NOT INCLUDED):

6-channel or greater R/C helicopter system with 120° CCPM function (see list below)

- 5 servos
- 100mAh receiver battery
- Gyro

CCPM-Ready JR Radio Systems

Most current JR Heli radio systems (XP652, XP8103 w/digital trims, 10X, as well as older 10 series systems) are equipped with 120° CCPM electronics for use with the Ergo CCPM machines. Radios you may be flying now, like the X347, X388S, XP783, and XP8103* have CCPM capability built in, but require activation by the Horizon Service Department. Please call (217) 355-9511 for details.

*Please note that many XP8103 systems have the CCPM function already activated. Please check with the Horizon Service Center for details.

CURRENT RADIO SYSTEMS

JRP1656** PCM 10X, 5-8231 Servos (50/53/72MHz)
 JRP165TX PCM 10X, Transmitter Only (50/53/72MHz)
 JRP8622** XP8103FM, 5-517 Servos (50/53/72MHz)
 JRP8653** XP8103PCM, 5-531 Servos (50/53/72MHz)
 JRP6622** XP652 FM, 5-517 Servos (50/53/72MHz)
 JRP6822 XP662 FM, 5-537 Servos (72MHz)



JR XP652/XP662



JR 10X



JR XP8103 DT



JR AirPac™



460T Piezo Gyro



12'' Aileron Extensions (2)

2. ENGINE REQUIREMENTS (NOT INCLUDED):

A .50 R/C helicopter engine is required.



JRP953001 IMZ RV50S



WEBE520 WEBRA52AAR

A special helicopter type muffler is also required.



KSJ478

3. BUILDING SUPPLIES (NOT INCLUDED):

The following items are needed to complete the assembly of the helicopter:



Glow Plugs



Fuel Filter



Silicone Fuel Tubing



Threadlock
(blue and red required)



Whip Antenna



Double-Sided Servo
Mounting Tape



Nylon Wire Ties



Heavy-Duty
Servo Arms (3)

4. TOOLS NEEDED TO ASSEMBLE THE HELICOPTER (NOT INCLUDED):



Phillips Screwdriver



Nut Drivers: 5mm, 7mm



Needle-Nose Pliers



Scissors



Drill and Drill Bits



Small Hammer



X-ACTO Knife



Metric Ruler



Ball Link Pliers



Allen Wrenches:
1.5, 2.0, 2.5, 3.0mm



Blade Balancer



Ball Link Sizing Tool

5. FIELD EQUIPMENT REQUIRED (NOT INCLUDED):



12-Volt Electric Starter



12-Volt Starting Battery



1.5-Volt Glow Plug Battery

or



Remote Glow Plug Adaptor



Helicopter Fuel: 15%–30%



Fuel Pump



Hex Starting Shaft



Pitch Gauge

HARDWARE IDENTIFICATION

There are many various sizes and shapes of hardware included in this kit. Prior to assembly, please be careful to identify each screw by matching it to the full-size outlines included in each step.

All of the hardware, screws, nuts, etc., contained in the Voyager kit are described in the following A, B, C manner:

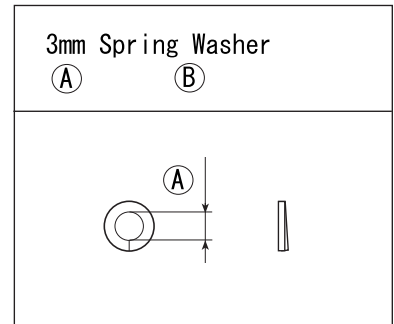
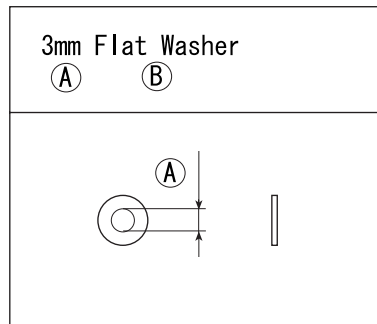
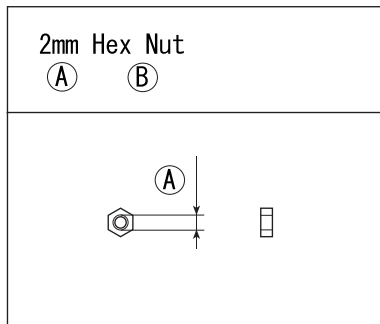
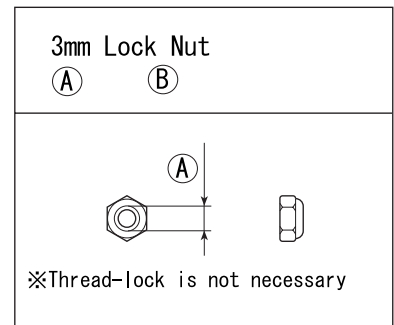
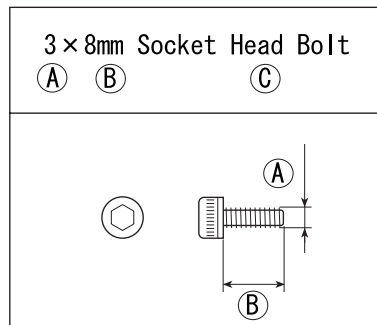
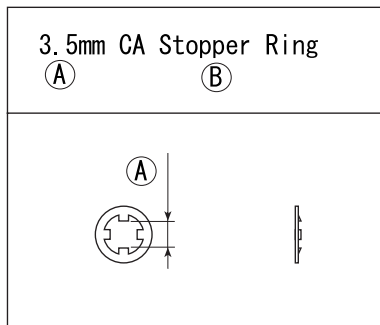
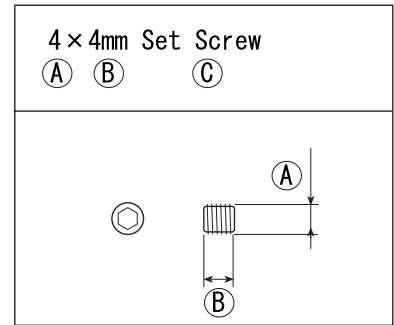
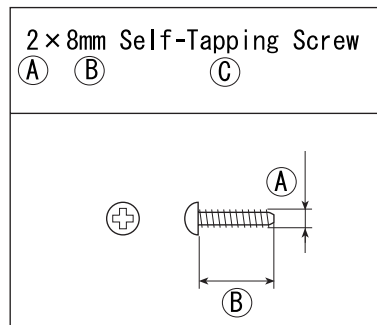
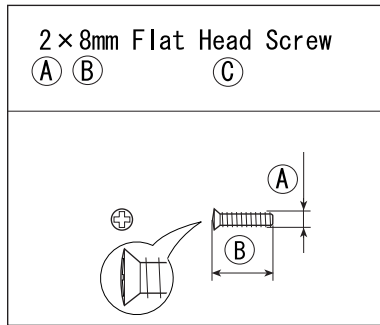

1-1

CLUTCH BELL/START SHAFT ASSEMBLY

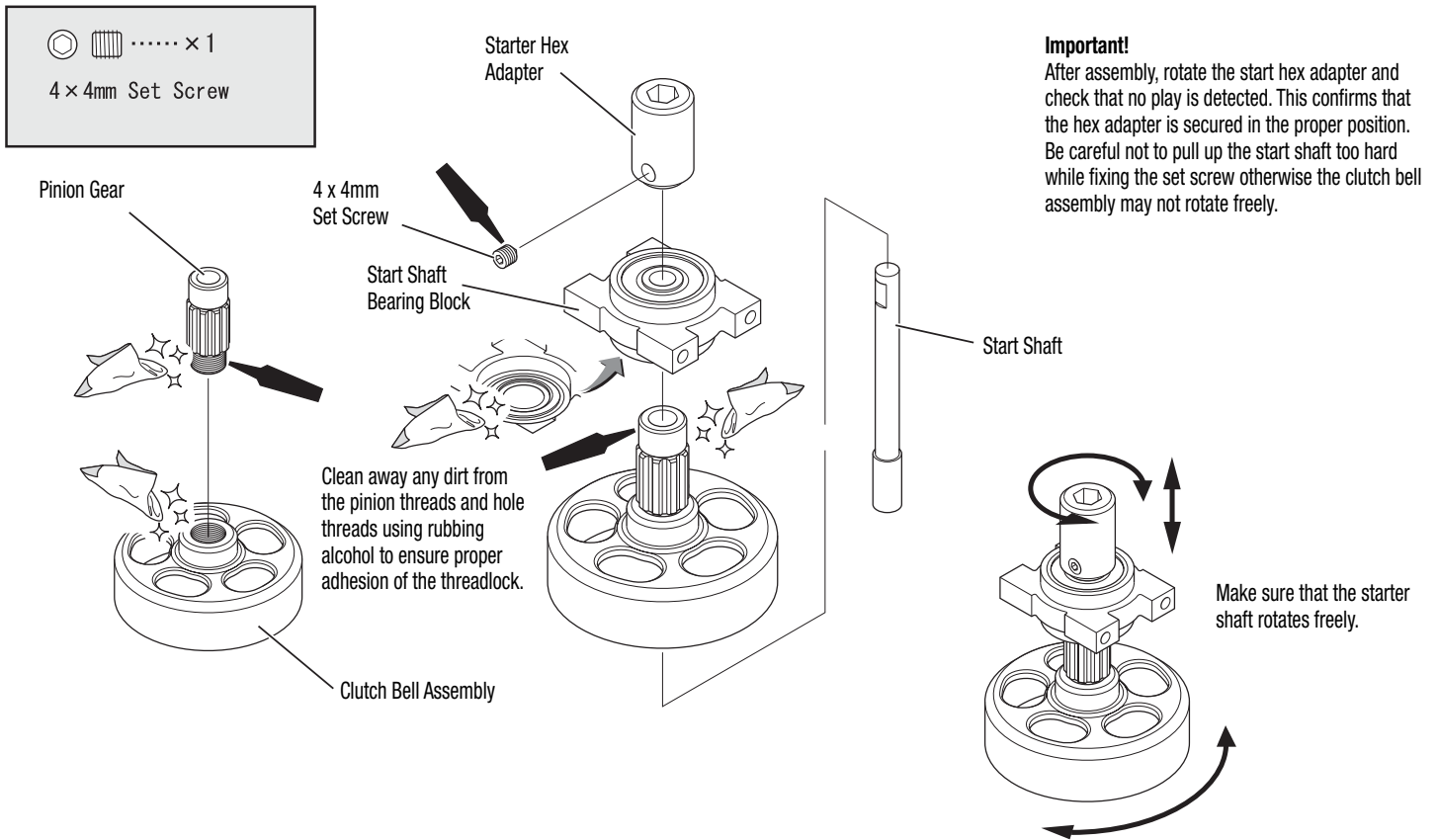

1-2

TAIL DRIVE PINION/BEARING BLOCK ASSEMBLY

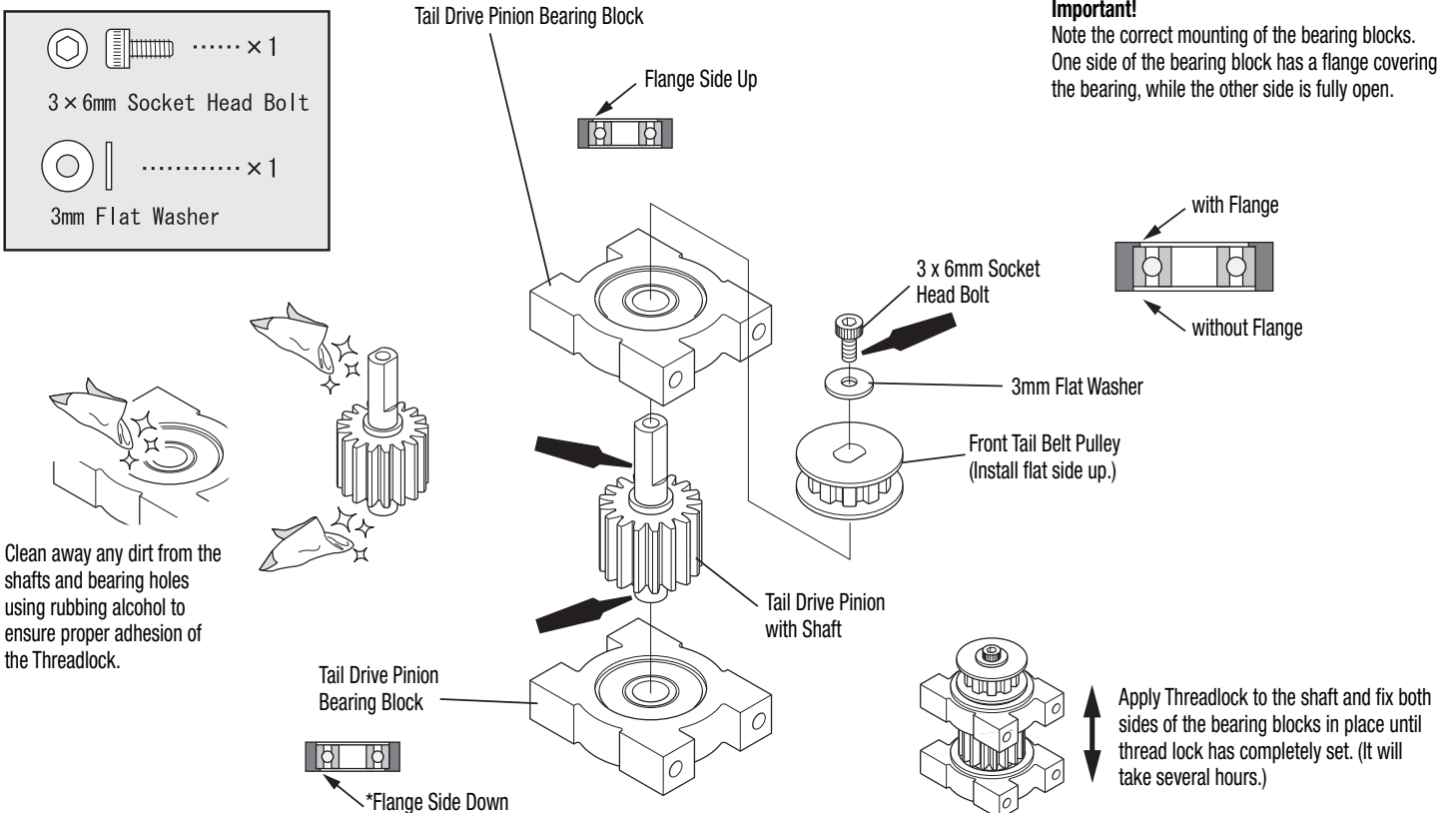

1-3

ELEVATOR ARM ASSEMBLY

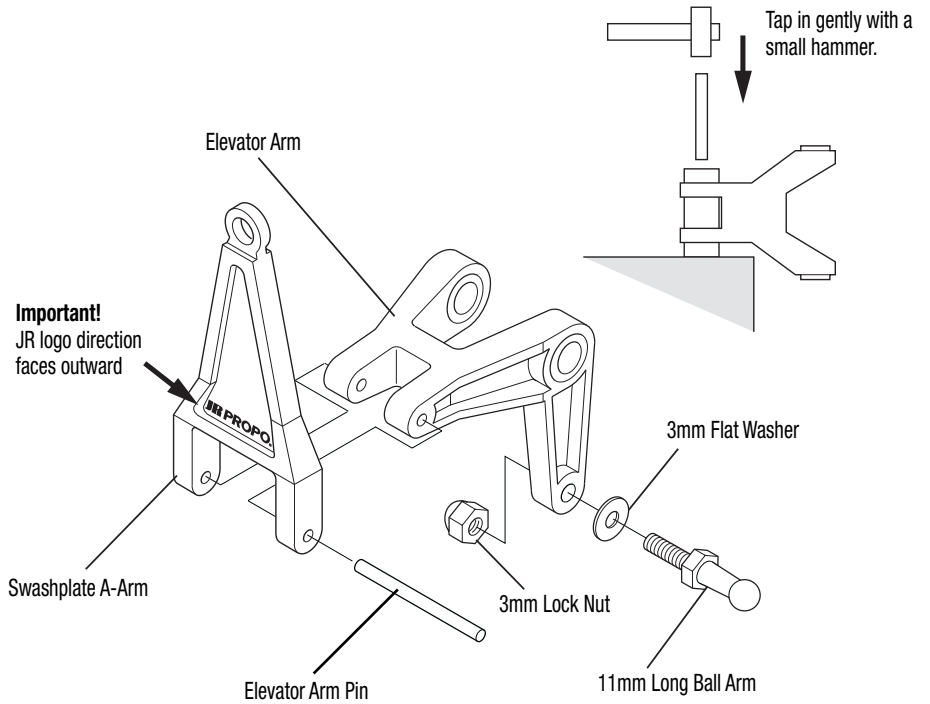
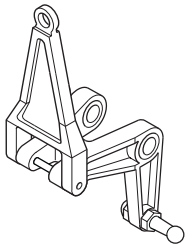
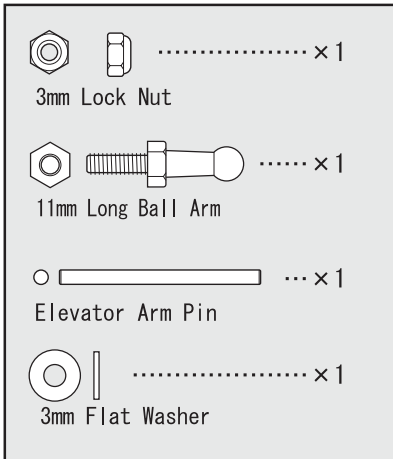

1-4

FUEL TANK ASSEMBLY

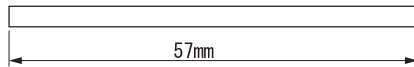
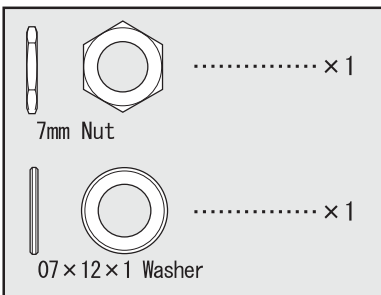

Trim before installation to a length of 57mm.

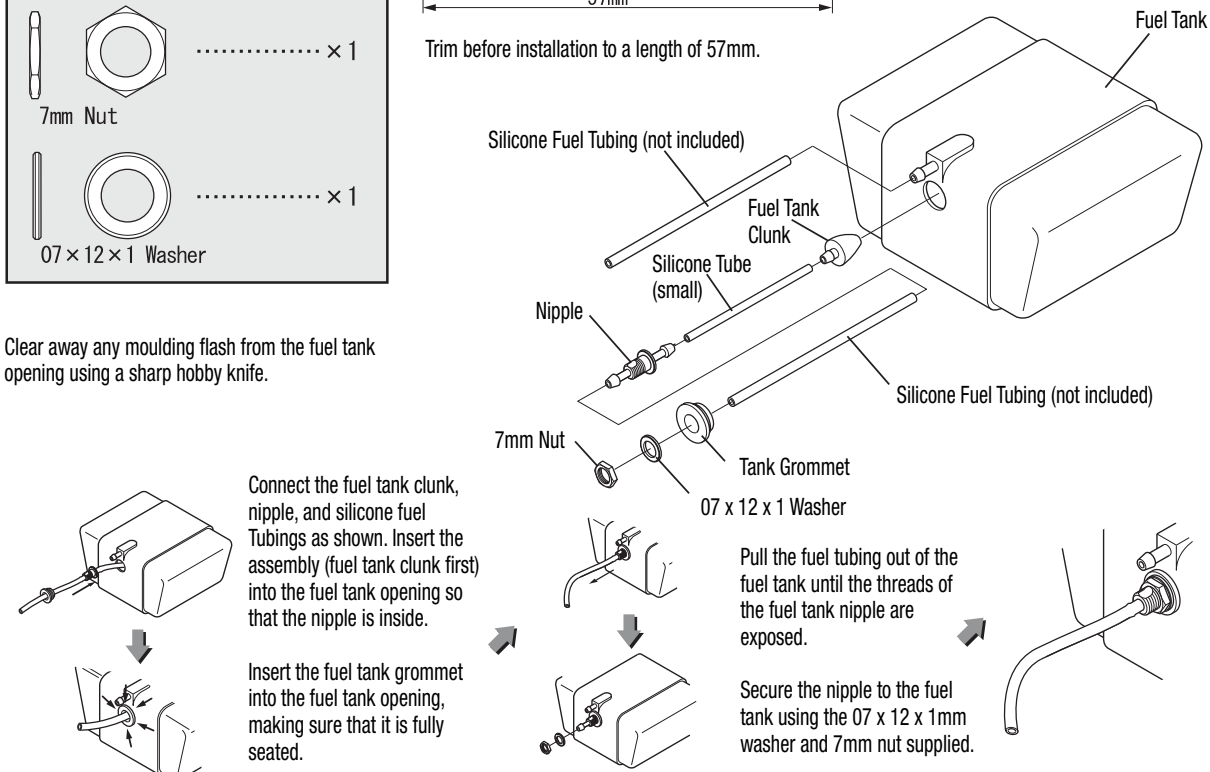



2-1

UPPER MAIN FRAME ASSEMBLY

 x 16
3 x 8mm Socket Head Bolt

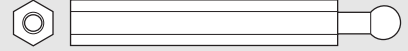
 x 1
Elevator Arm Bushing, 32mm

 x 2
Body Mounting Standoff, 37mm

 x 2
Nylon Washer (0.5)

 x 3
Servo Wire Holder

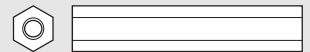
 x 2
Main Frame Standoff, 32mm

 x 3
3mm Flat Washer

 x 12
3.5mm CA Stopper Ring

 x 4
2.6 x 8mm Self-Tapping Screw

Important!

- Be sure to note left & right main frame positions.*
- First, temporarily install all parts. Place the assembly on a flat surface and make sure that the bottom of each frame remains level while tightening the screws to prevent twisting. Secure firmly.
- Be sure to note the orientation of upper and lower main shaft bearing blocks.
- When installing the lower main shaft bearing block, secure the bolts while pushing the bearing block downward.

The edges of the screw holes in the main frames are not coated. This ensures good grounding between the frame parts and helps minimize electrical noise. Non-coated sides of frame should face out.



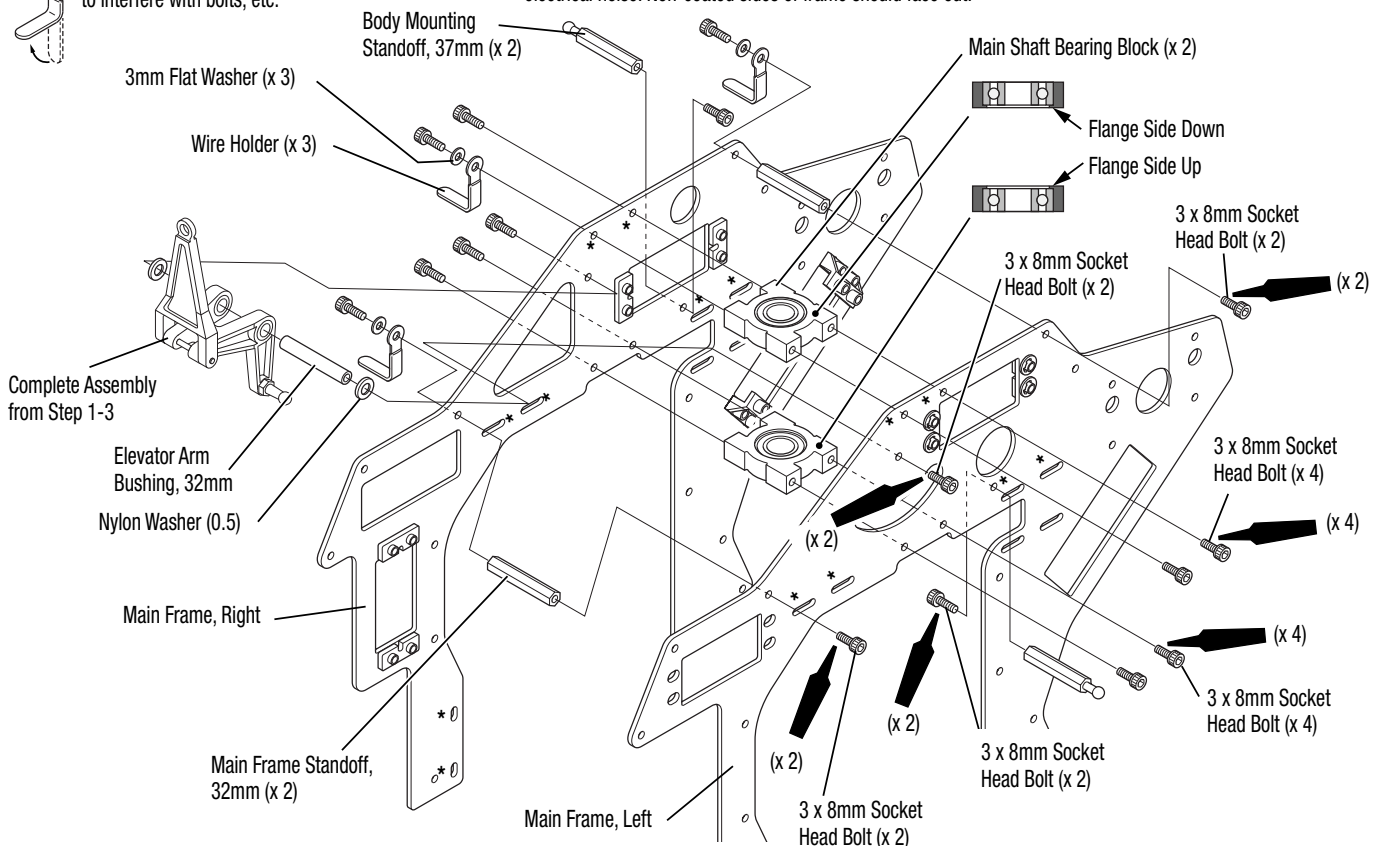

Bend the wire holders so as not to interfere with bolts, etc.



2-2

CLUTCH/TAIL PINION INSTALLATION

 x 12
3 x 8mm Socket Head Bolt

 x 12
3mm Flat Washer

Important!



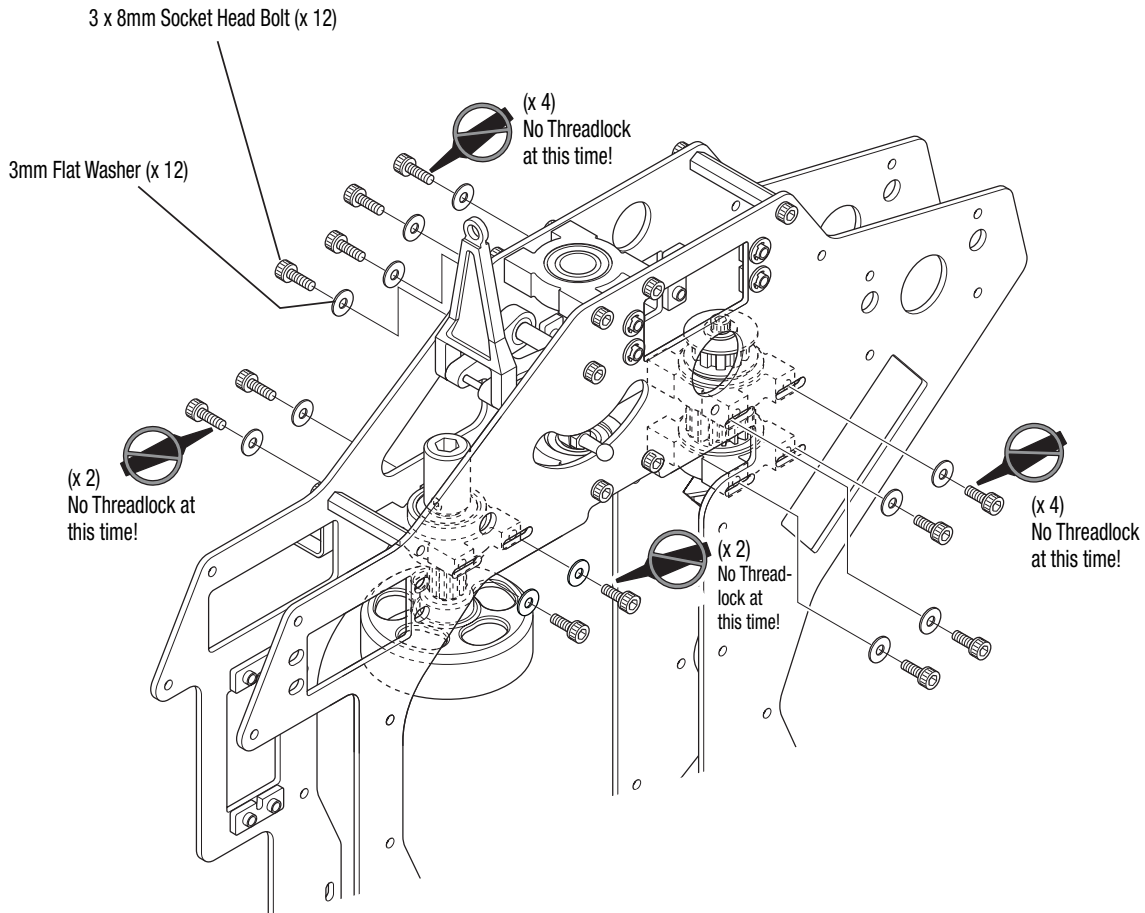
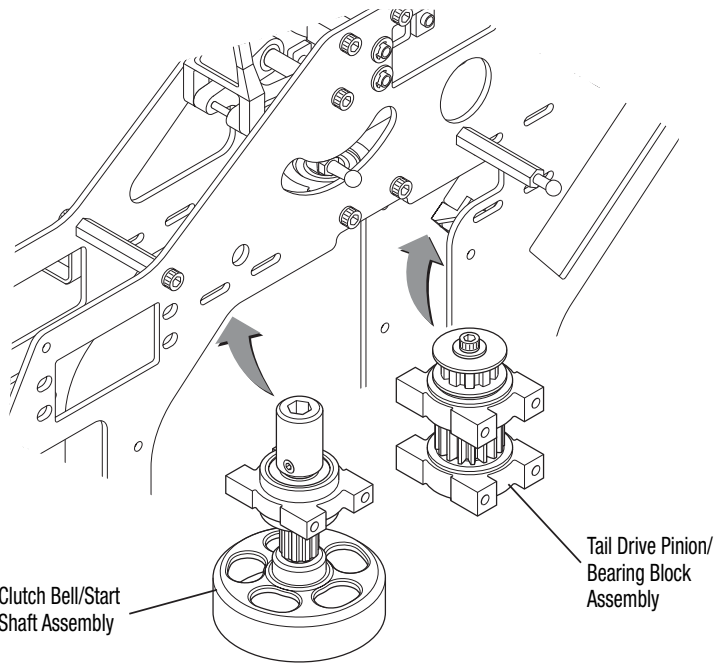

Both the clutch bell/start shaft assembly (Step 1-1) and the tail drive pinion/bearing block assembly (Step 1-2) are temporarily installed at this time. These assemblies will be adjusted and secured in Step 3-2.

Do not apply Threadlock to bolts at this time.



2-3

BOTTOM FRAME ASSEMBLY

- | | |
|---|---|
|  × 4 |  × 3 |
|  × 1 |  × 4 |
|  ... × 2 | |

Important!

Note the correct orientation of the main frames crossmember when installing them in the front and rear locations.

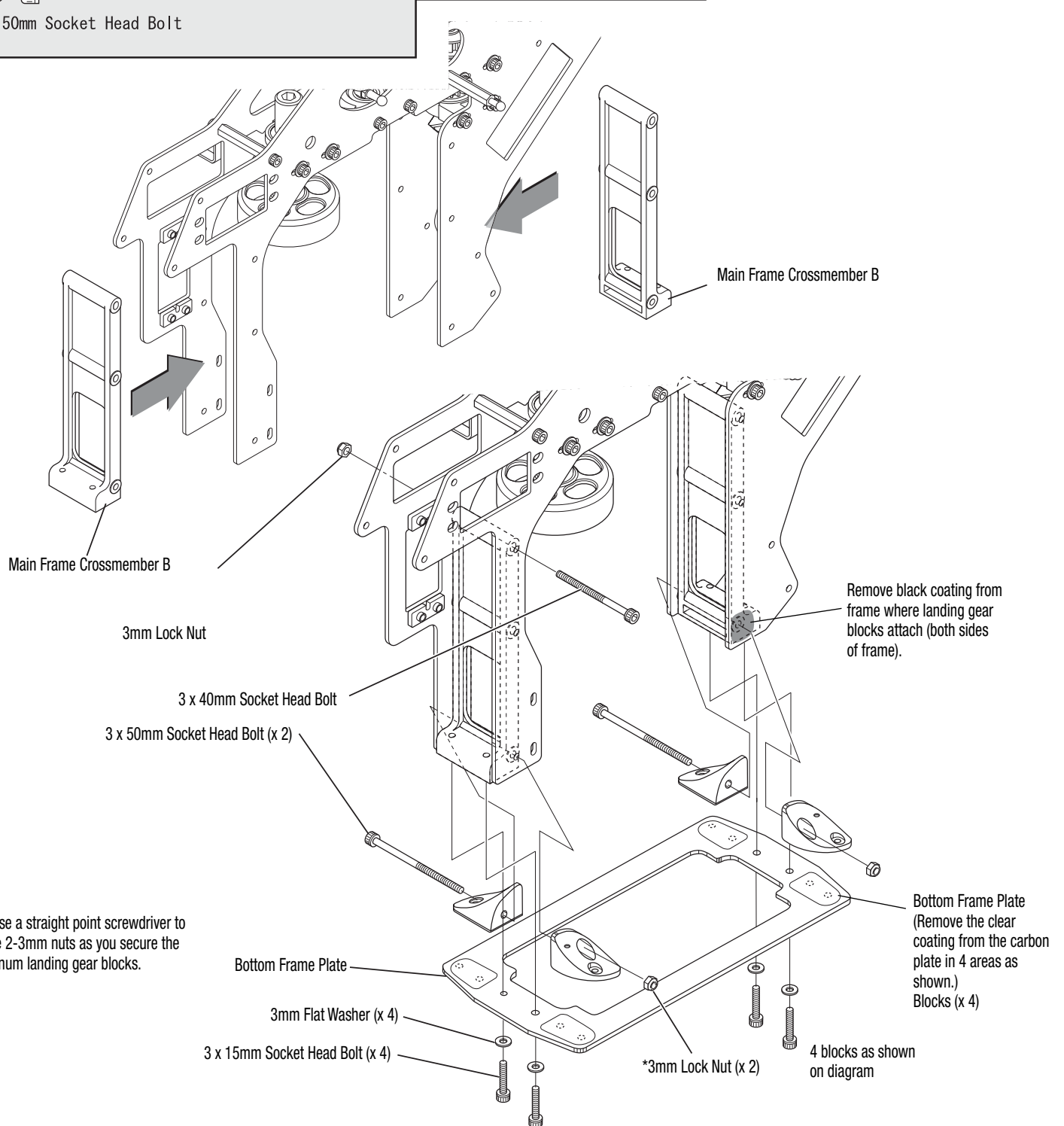



*** Note:** Use a straight point screwdriver to hold the 2-3mm nuts as you secure the 4 aluminum landing gear blocks.

2-4

FAN COVER STAY INSTALLATION

 × 4
3 × 6mm Socket Head Bolt

 × 4
Main Frame Standoff, 12mm

 × 2
Floating Dampener

 × 3
3 × 47mm Threaded Rod

Important!

- Screw the main frame standoff (12mm) and the floating dampener into one side of the 3 x 47mm threaded rods and apply Threadlock.
- Before installing within frames, make sure that the Threadlock has completely set. If not, the 3 x 47mm threaded rods could rotate and interfere with the 3 x 6mm socket head bolts which will be used later to attach the tank frames. If it takes too long for the Threadlock to set, warm using a hair drier to speed it up. (Step 2-4, 2-5)
- Secure the floating dampener using a 7mm wrench on the inside hexagonal face. Be careful not to damage the rubber or the hexagonal face while securing.

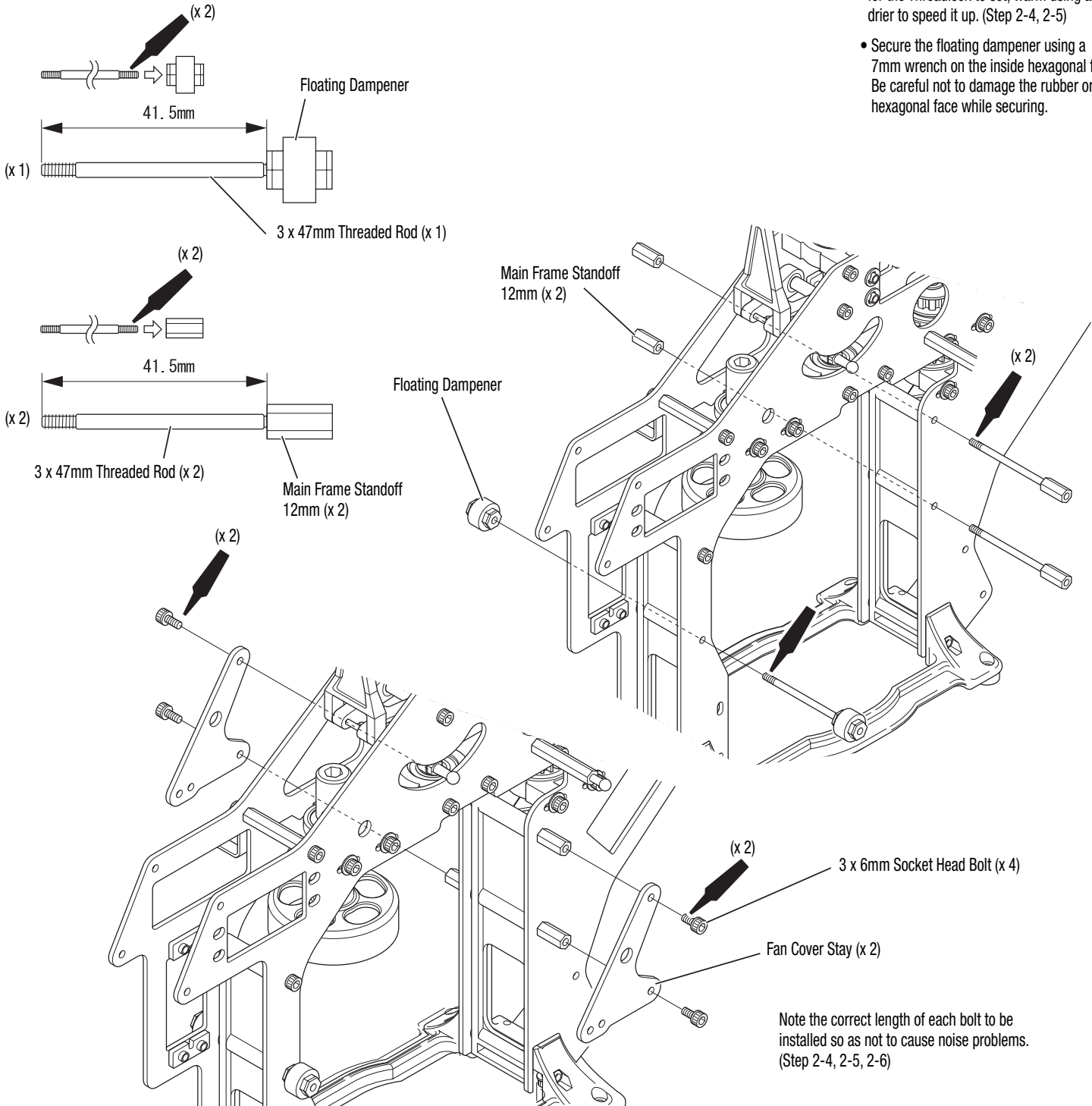

Note the correct length of each bolt to be installed so as not to cause noise problems. (Step 2-4, 2-5, 2-6)

2-5

TANK FRAME ASSEMBLY

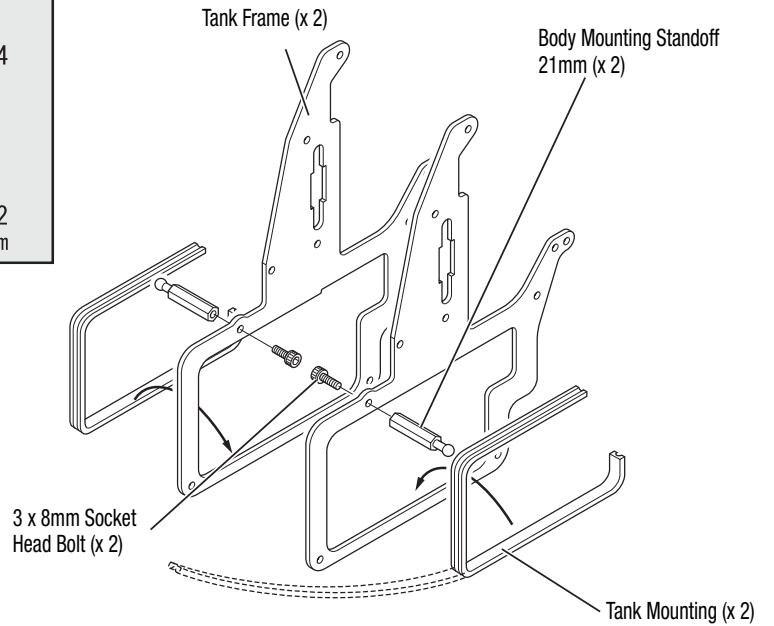
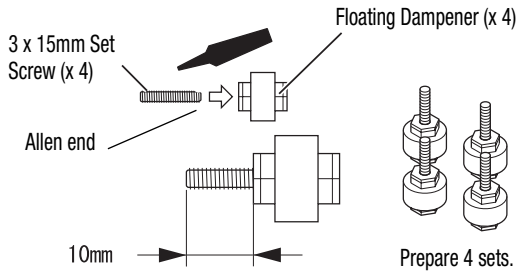
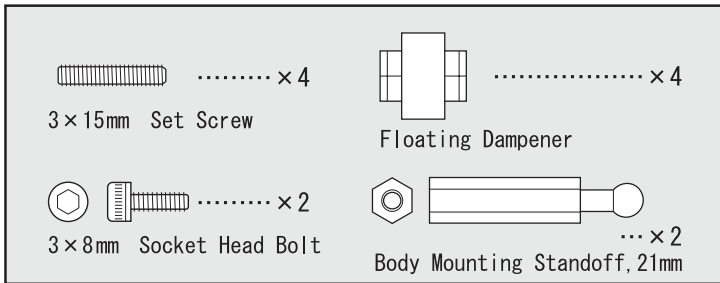

2-6

FUEL TANK INSTALLATION

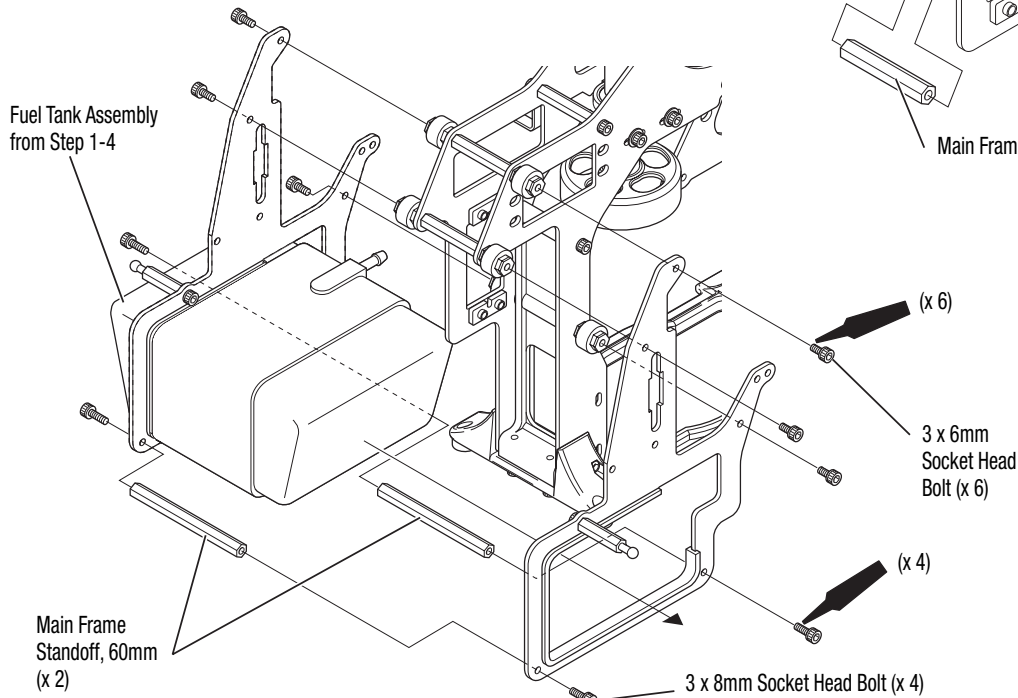
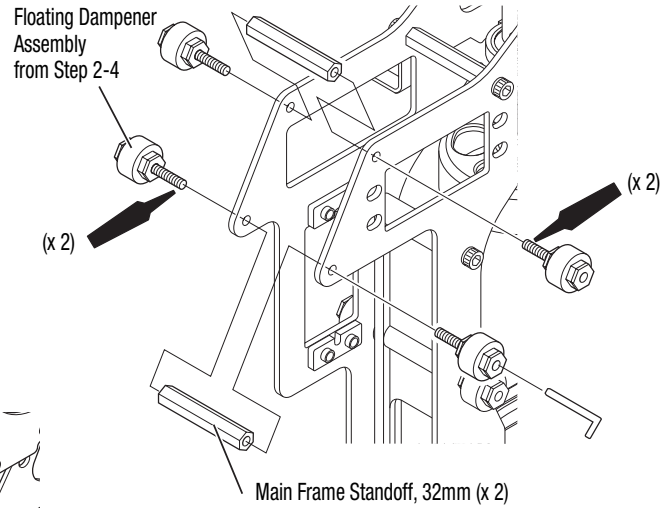
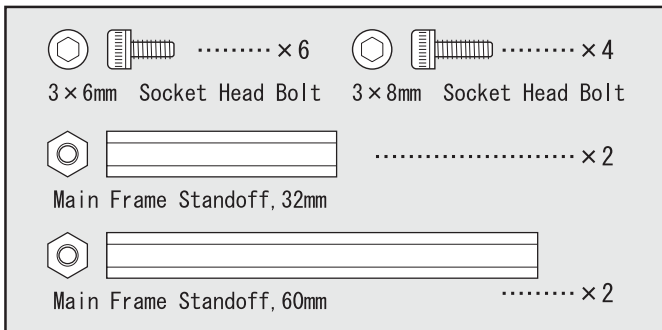

Important!
Secure the floating dampener using a 7mm wrench on the inside hexagonal face. Be careful not to damage the rubber or the hexagonal face when tightening.

2-7

FRONT RADIO BED/COOLING FAN SHROUD INSTALLATION

  x 4

3 x 10mm Socket Head Bolt

 x 4

2.6 x 8mm Self-Tapping Screw

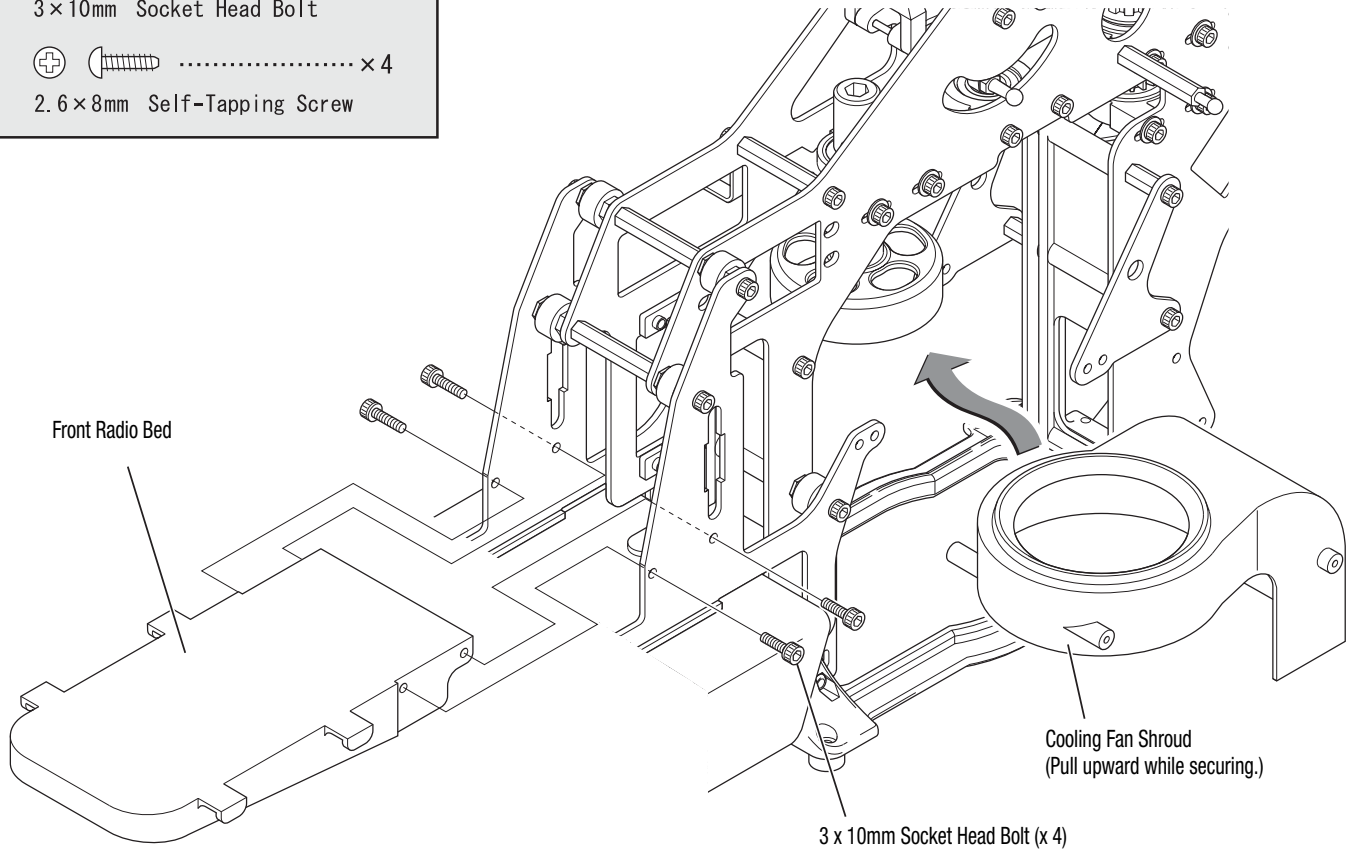

2.6 x 8mm Self-Tapping Screw (x 4)

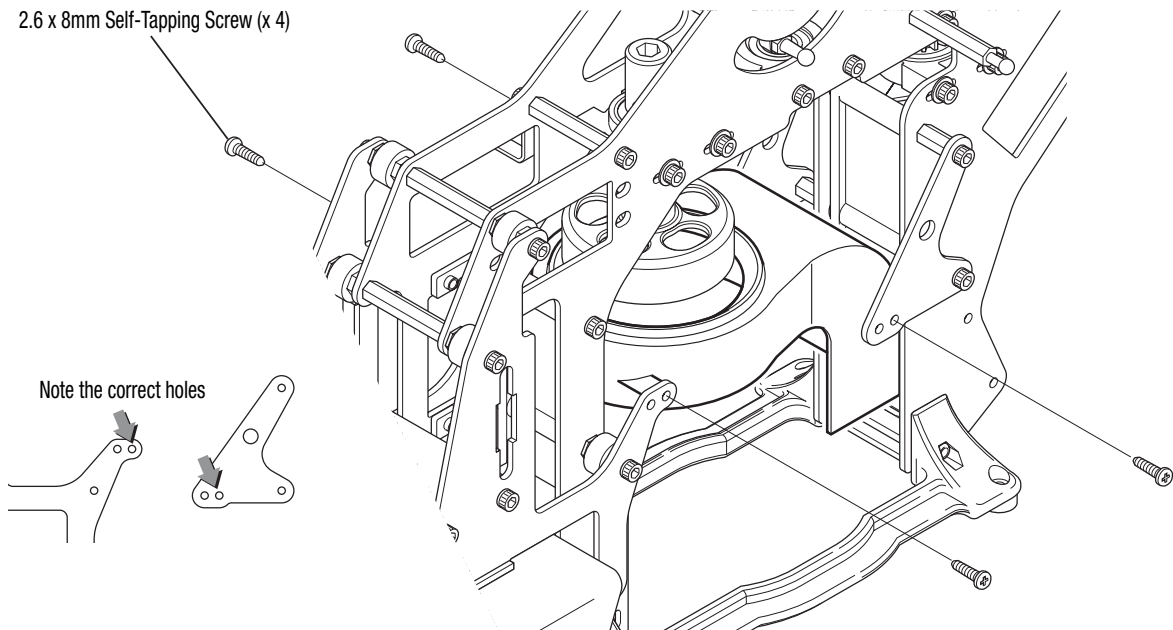

3-1

MAIN DRIVE GEAR/AUTOROTATION ASSEMBLY

 x 4
3 x 6mm Socket Head Bolt

Important!

Apply a small amount of oil periodically to the places indicated by the white arrows. Do not apply silicone grease or oil to the bearing (indicated by the black arrows) as it could cause damage.

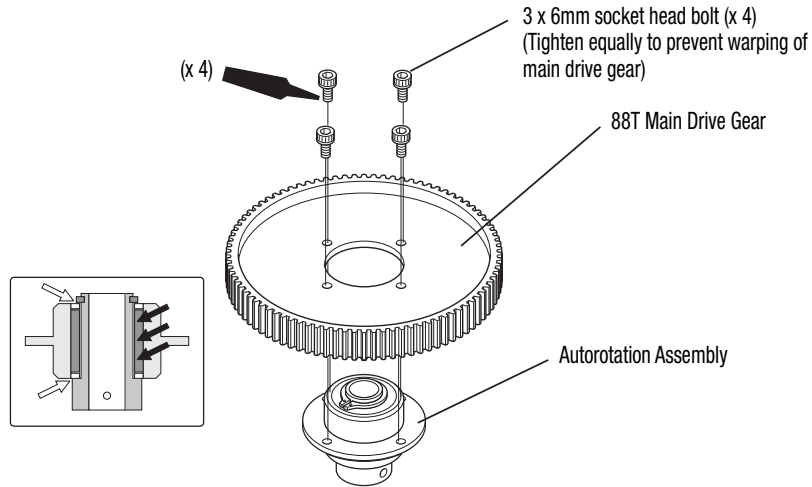

3-2

MAIN DRIVE GEAR/AUTOROTATION ASSEMBLY INSTALLATION

 x 4
4 x 4mm Set Screw

 x 1
3 x 22mm Socket Head Bolt

 x 1
3mm Lock Nut

Main Rotor Shaft Up

Main Shaft Collar Down

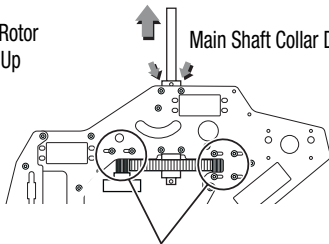

Secure the bolts (12pc).

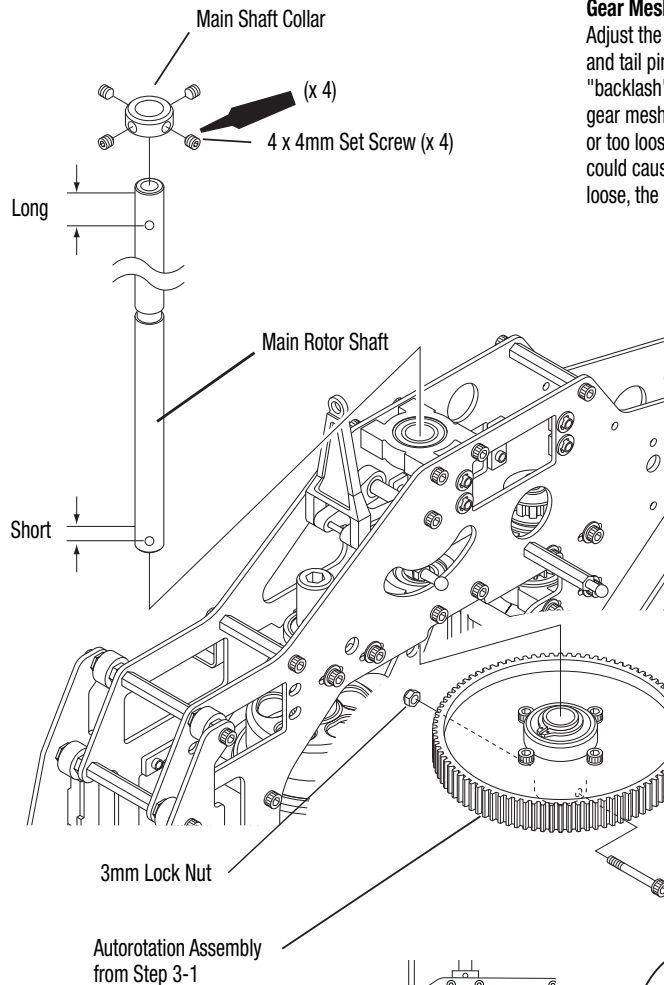

Gear Mesh Adjustment

Adjust the gear mesh of both the main and tail pinions so that a slight amount of "backlash" is achieved. When setting the gear mesh, make sure that it is not too tight or too loose. If the gear mesh is too tight, it could cause gear cracks etc, and if it is too loose, the gear will not rotate smoothly.

Apply Threadlock to bolts left loose from Step 2-2 at this time.

Important!

- Secure the autorotation hub to the main rotor shaft using the 3 x 22mm socket head bolt. Next, slide the main shaft collar onto the main rotor shaft, while pulling upward on the main rotor shaft, securing the main shaft collar to the main rotor shaft using the four 4 x 4mm set screws.
- Once the main shaft assembly is in place, adjust the gear mesh of the clutch bell and tail belt pinion gears and secure the bolts (12pc) left loose from Step 2-2.
- After installing the main drive gear assembly, make sure that the main frames and the main drive gear do not come into contact with each other.

3-3

ENGINE MOUNT ATTACHMENT

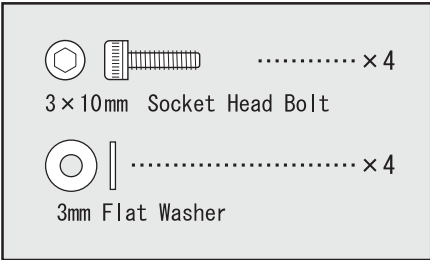

Important!

- Secure the engine mount temporarily.
- Note the proper orientation of the engine mount.
- If you find difficulty installing the engine mount, loosen the 3 x 50mm socket head bolt securing the bottom frame.
- If using the JR IMZRV505 engine, install the correct motor mount at this time.

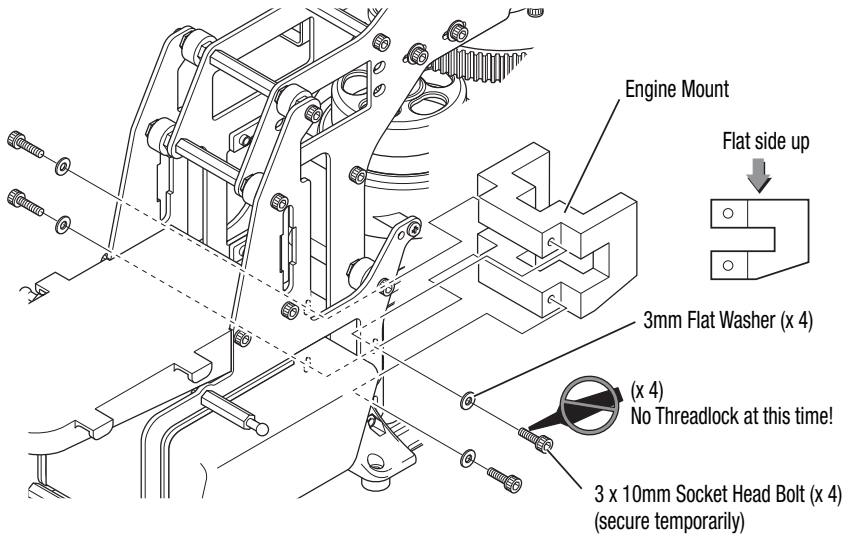

3-4

LANDING GEAR ASSEMBLY INSTALLATION

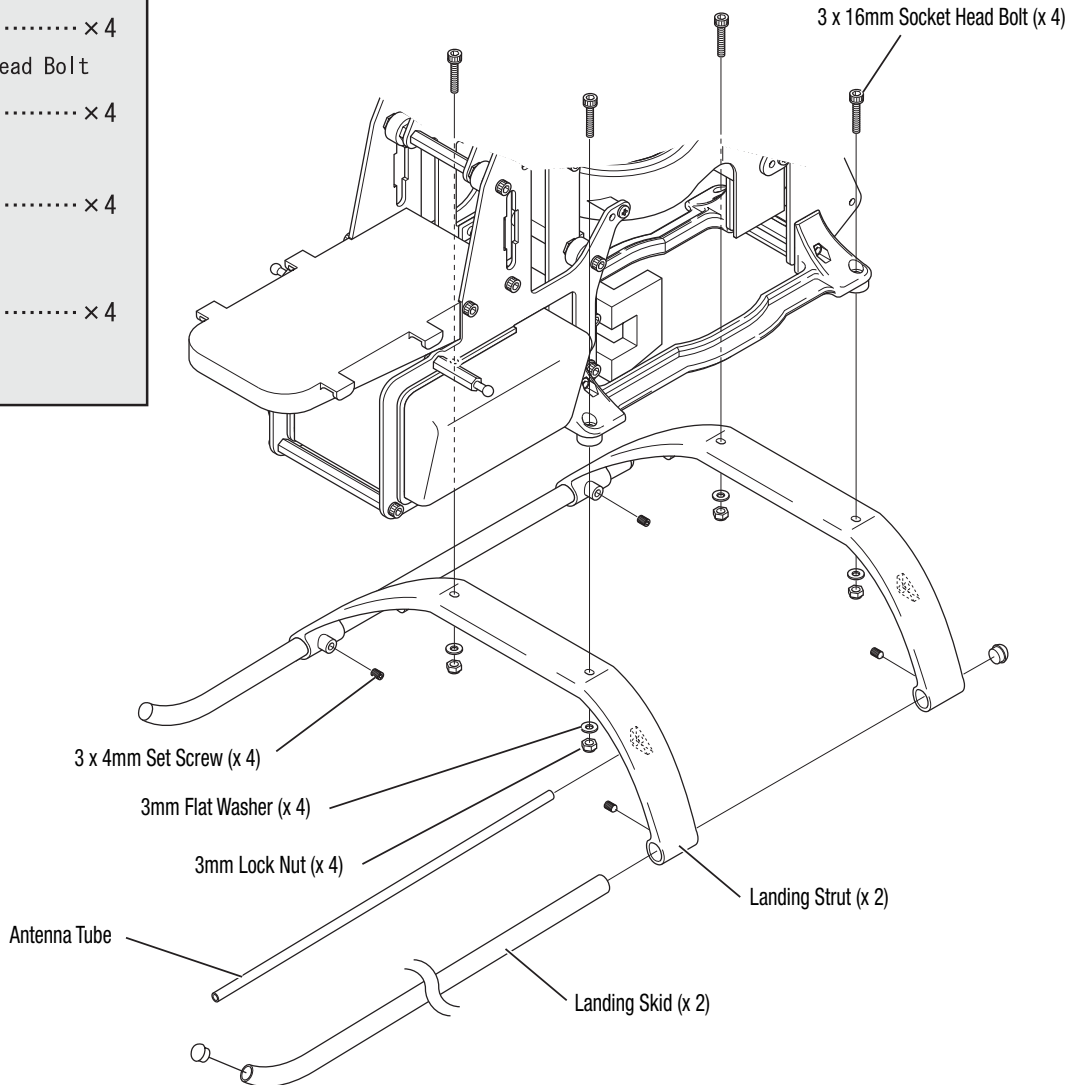
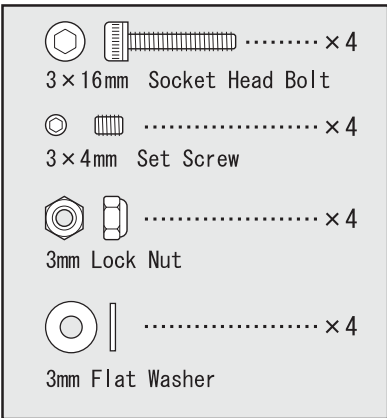

3-5

COOLING FAN/HUB INSTALLATION

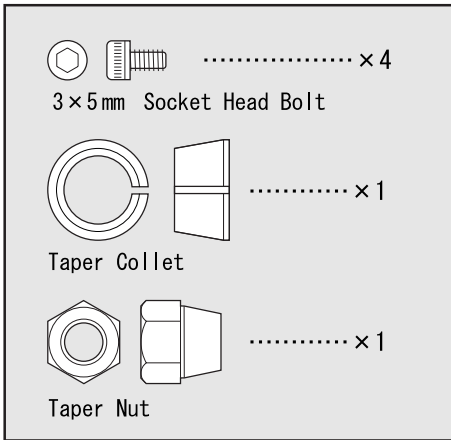

Important!

- Remove the drive washer supplied with the engine and use the black washer only.
- Slide the taper collet onto the engine crankshaft and push up to the crankcase. (It may be a tight fit.)
- Clean away any debris from the taper nut and taper collet to achieve precision alignment. Make sure to clean the inside of the cooling fan hub.
- Secure the taper nut firmly with one hand while holding the cooling fan, wrapped with a towel, with the other hand.

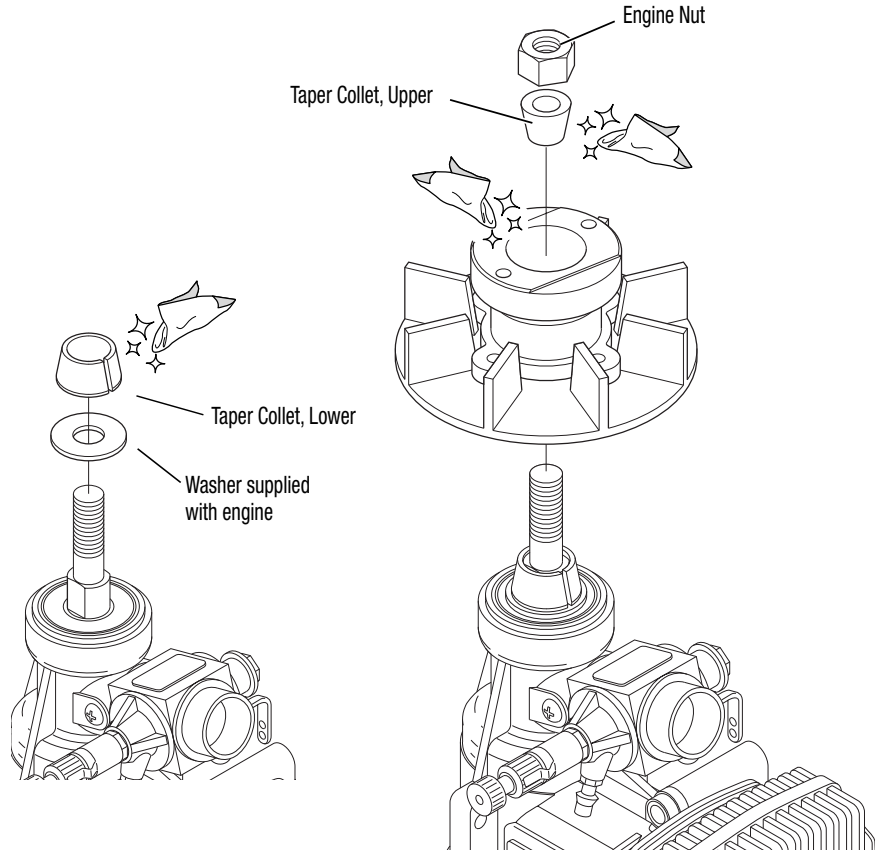
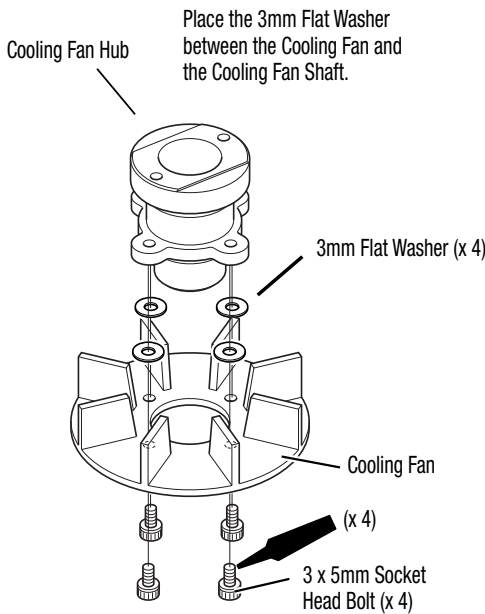

3-6

CLUTCH ASSEMBLY ATTACHMENT

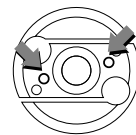
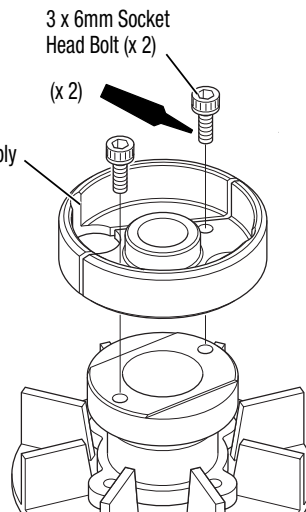
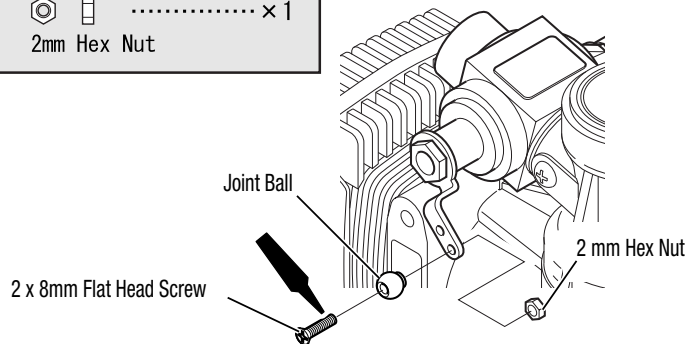
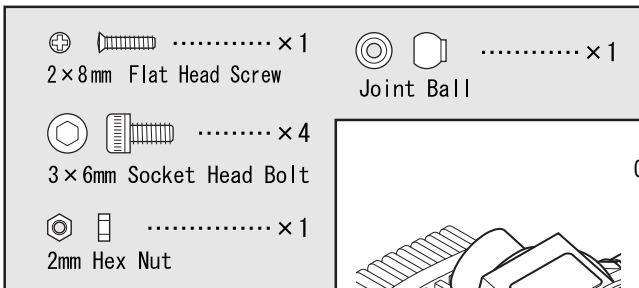

Important!

- Attach the clutch assembly evenly, otherwise it could cause damage.
- Use the inside holes to attach the clutch assembly. The outside holes are used to remove the clutch assembly by thrusting bolts into them.

3-7

ENGINE INSTALLATION

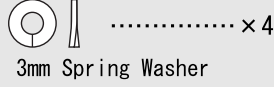
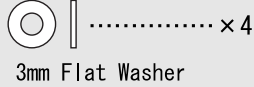

Important!

- Secure the engine firmly and make sure it will not become loose as Threadlock is not used during assembly. This allows for ease of maintenance afterward. Adjust the height and position of the engine as shown below so the clutch assembly sits just below the clutch bell by about 0.5mm. If the clutch assembly tilts, loosen the start shaft bearing block screws (4pc) and square up, then readjust the gear mesh. Secure the screws again after adjustment.
- Check to insure that the starter hex adapter rotates freely. If this is not the case, reset the central alignment of the engine.
- Secure the 3 x 10mm socket head bolts (temporarily secured in Step 3-3) using Threadlock.

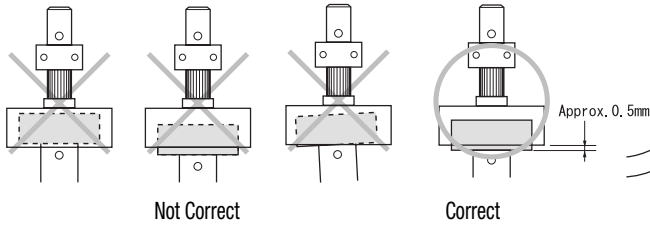
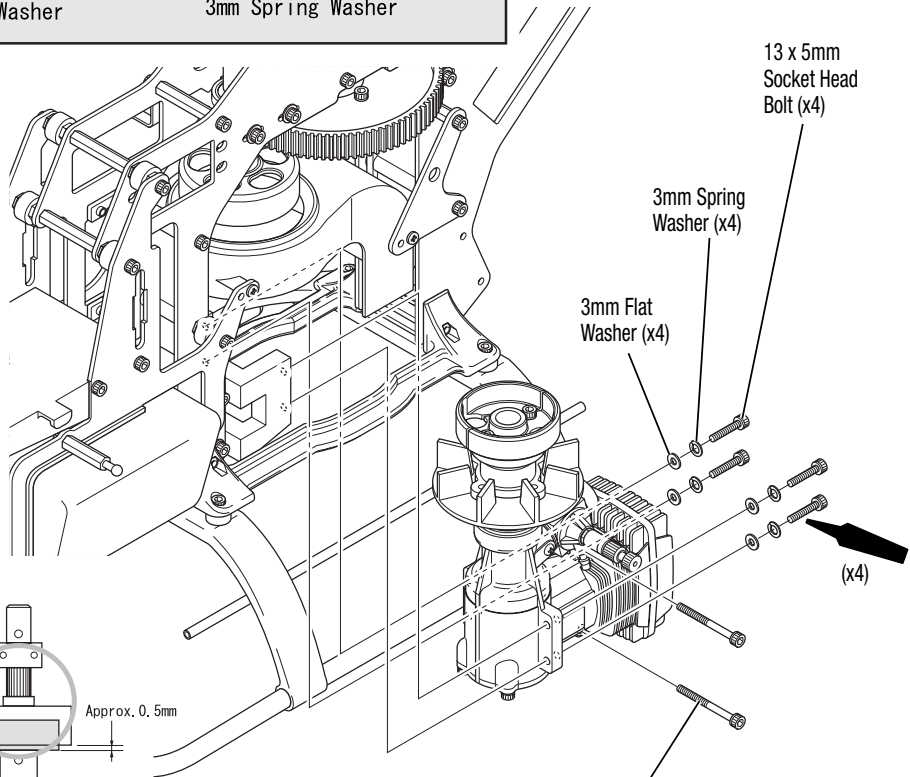

It is highly recommended that you insert the muffler bolts into the engine crankcase prior to installing the engine into the frame.

3-8

INSTALLATION OF THE MUFFLER

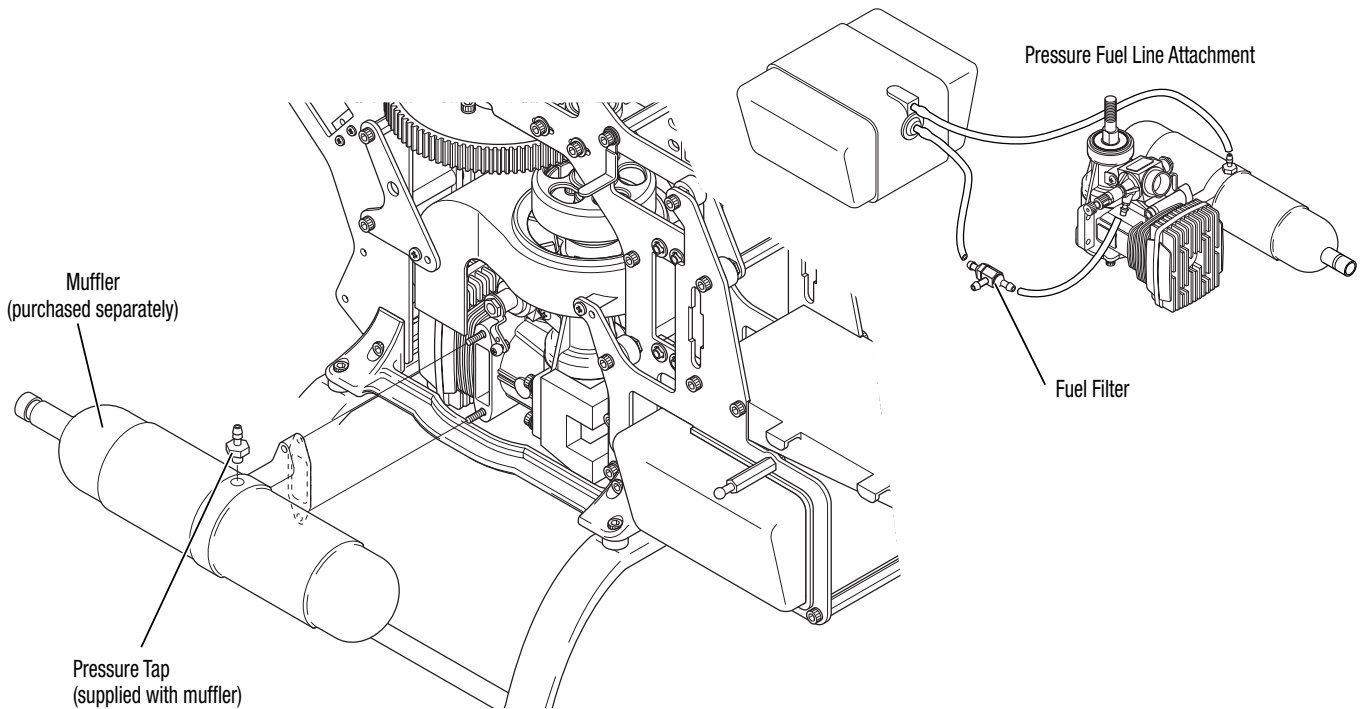

4-1

SWASHPLATE ADJUSTMENT



Important!

Swashplate Adjustment

The 120° swashplate assembly is adjustable via the 3-4 x 4mm set screws. If excessive play is found in the above test, gently tighten each of the 3-4mm set screws by the same amount and re-test. The swashplate should move freely, but without noticeable play.

Caution

If the 3-4mm set screws are over tightened, damage to the swashplate bearing can occur.

While holding the inside ball race, pivot the swashplate & check for excessive play. Adjust as necessary.

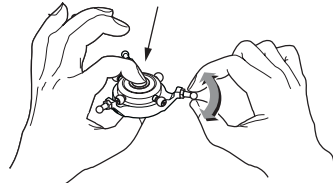

Swashplate Adjustment Test

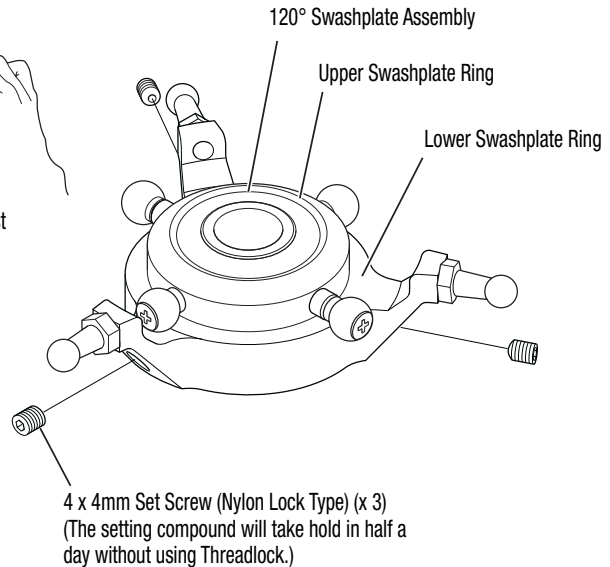

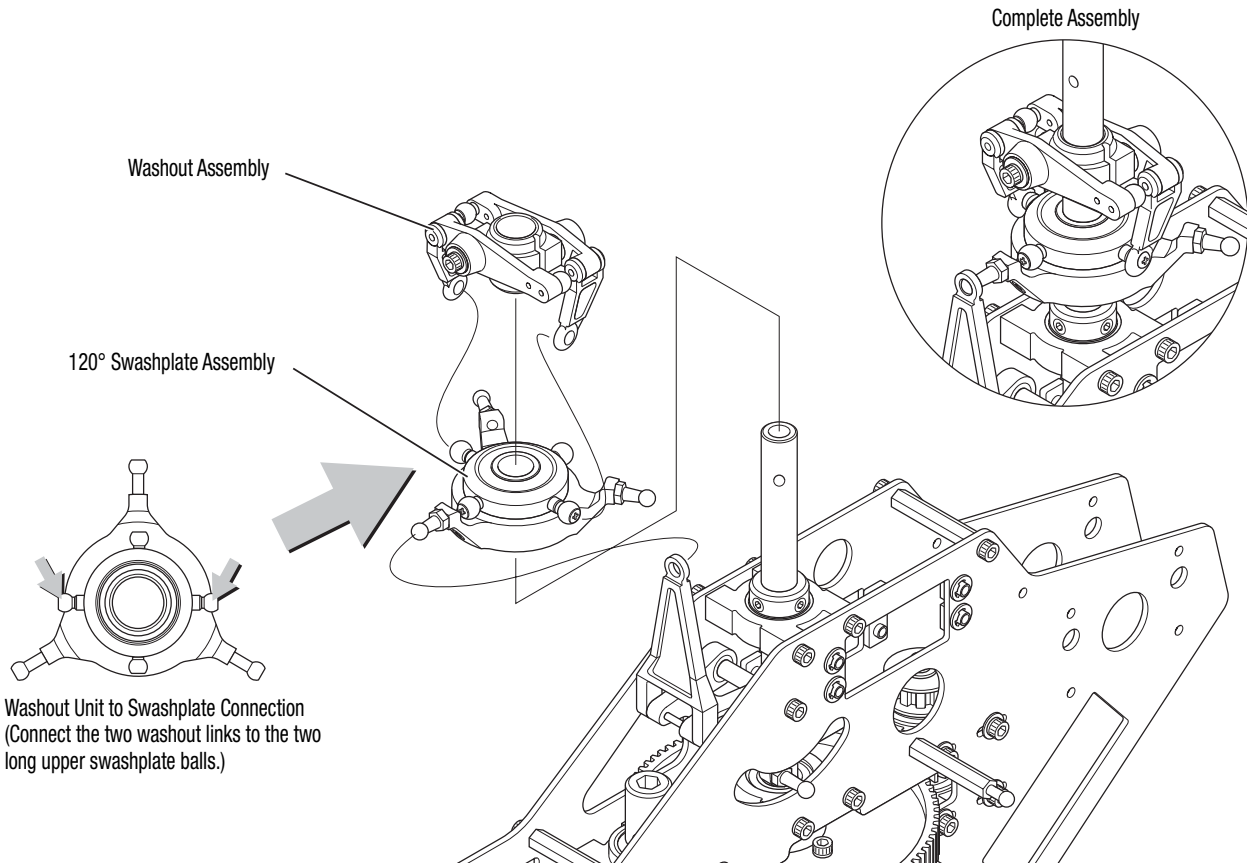

4-2

SWASHPLATE/WASHOUT ASSEMBLY INSTALLATION



4-3

ROTOR HEAD INSTALLATION

-  $\times 1$
3 x 18mm Socket Head Bolt
-  $\times 1$
3mm Lock Nut

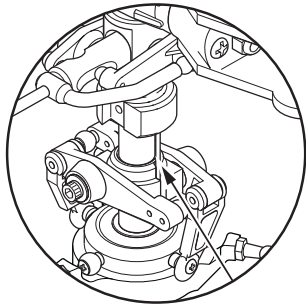

3 x 18mm Socket Head Bolt

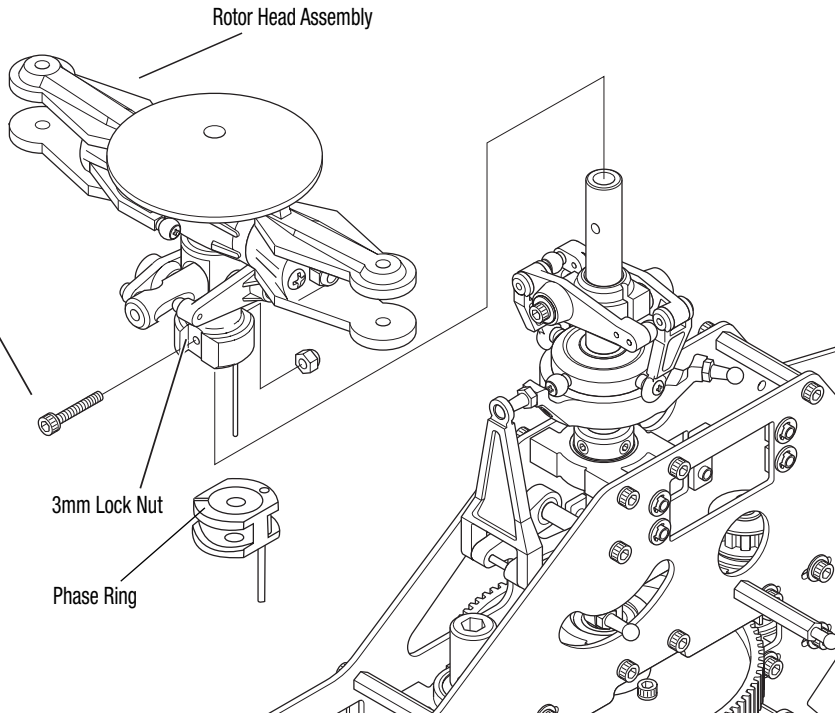

4-4

FLYBAR INSTALLATION

-  $\times 2$
4 x 4mm Set Screw

IMPORTANT!

Check to make sure that the two flybar control arms are parallel the center line of the flybar. Center the flybar in the seesaw shaft before securing the two flybar control arms. When securing the flybar, slightly push both flybar control arms inward so that they will stay in place.

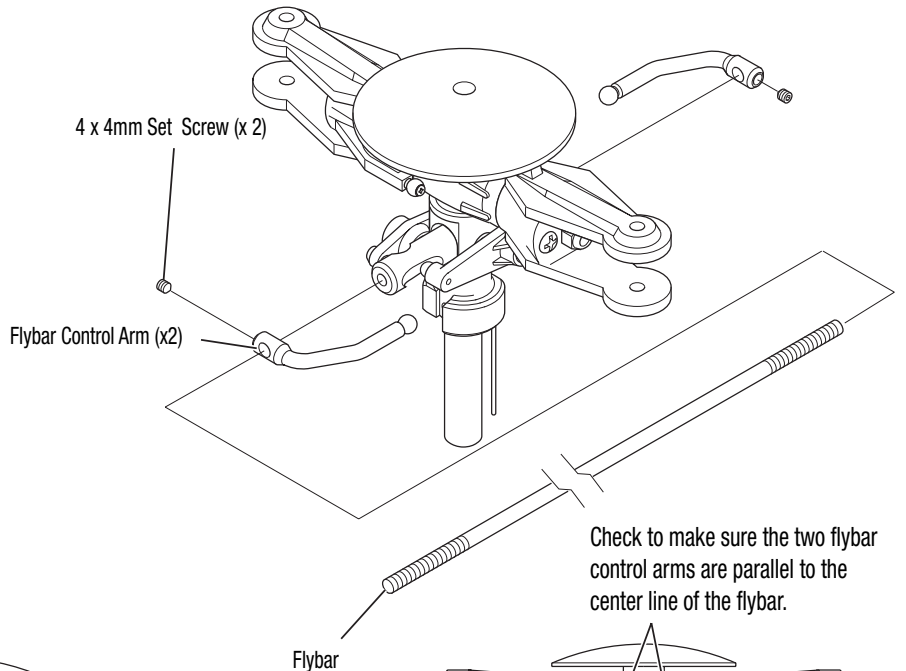

Check to make sure the two flybar control arms are parallel to the center line of the flybar.

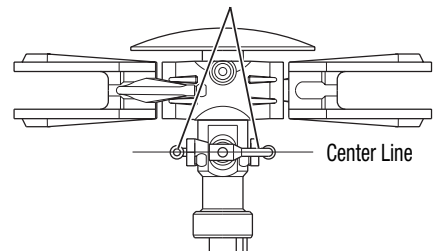
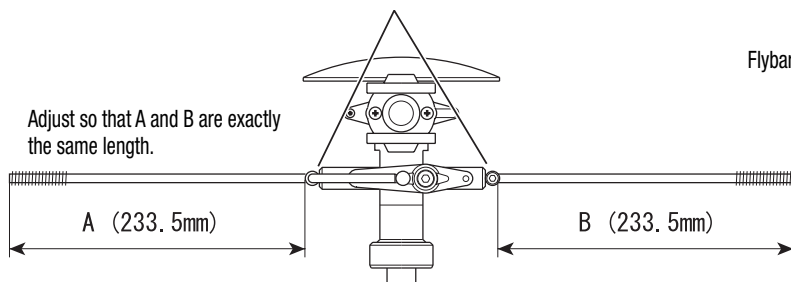

4-5

FLYBAR PADDLE ATTACHMENT

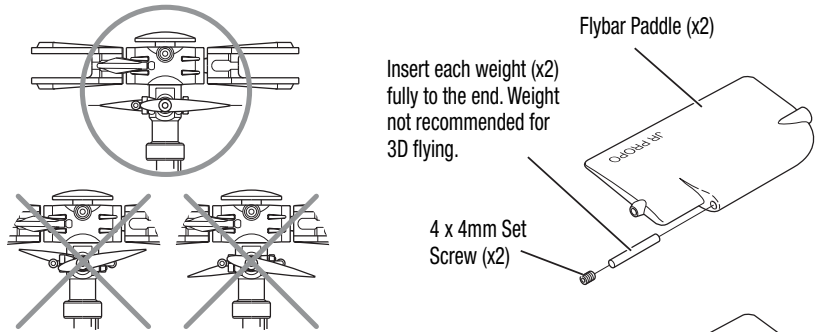
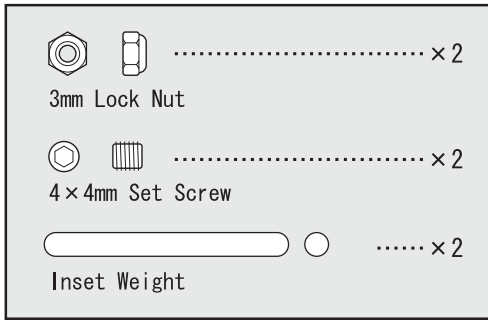

IMPORTANT!

Thread each flybar paddle onto the flybar until the threaded tip of the flybar protrudes approximately 5mm. Adjust each flybar paddle so they are parallel to the flybar control arms and to each other.

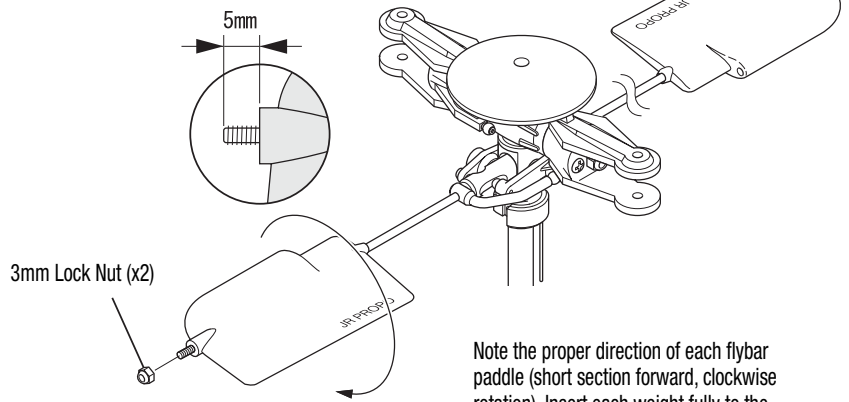

Note the proper direction of each flybar paddle (short section forward, clockwise rotation). Insert each weight fully to the end so that both ends balance.

4-6

ROTOR HEAD/SWASH CONTROL ROD INSTALLATION

IMPORTANT!

Thread each universal link onto the 2.3 x 40mm threaded rod to the length shown below. Note the correct direction of the universal link. Next, install each rod so the JR Propo logo faces outward.

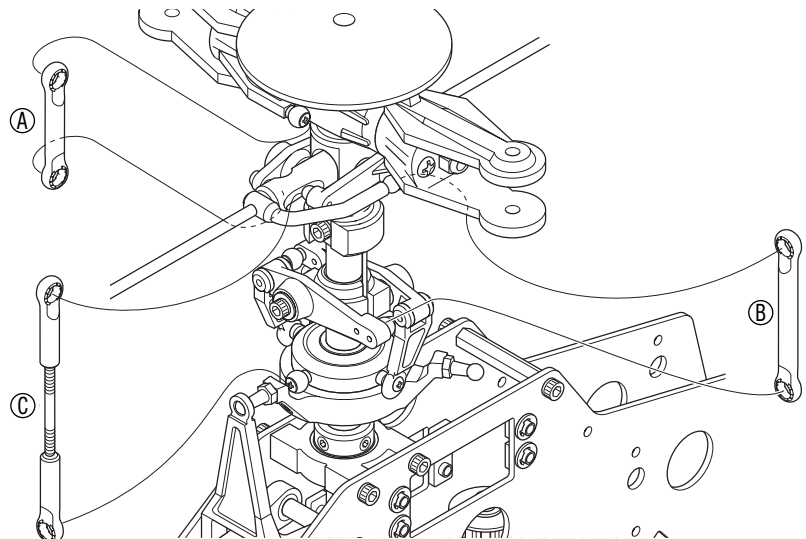

- (A) Seesaw Arm to Main Blade Holder
 (1 piece double link, short)

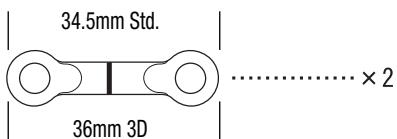

- (B) Washout Arm to Flybar Control Arm
 (1 piece double link, long)

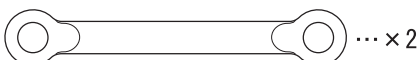

- (C) Swashplate to Seesaw Arm
 (2.3 x 40mm threaded rod)

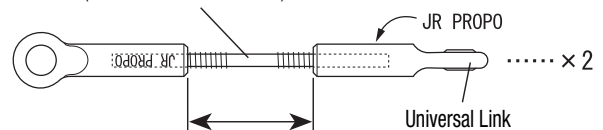

5-1

TAIL GEAR CASE ASSEMBLY

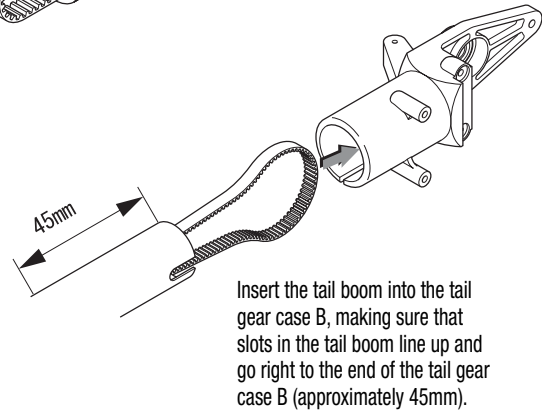
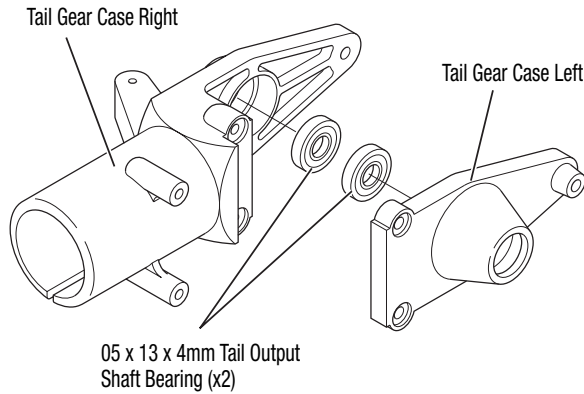
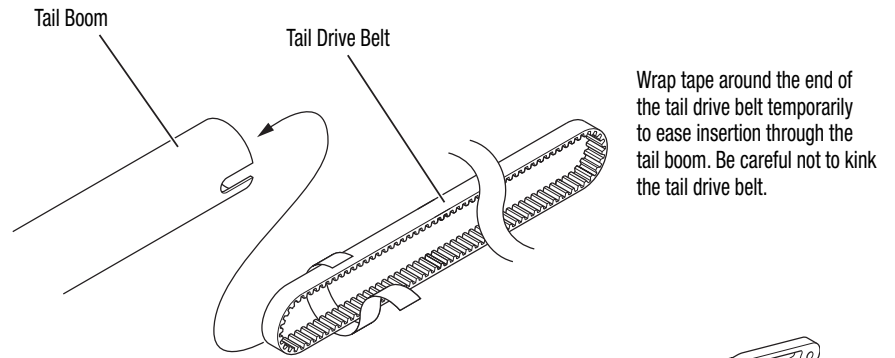
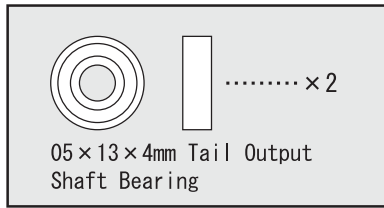

5-2

TAIL GEAR CASE ASSEMBLY 2

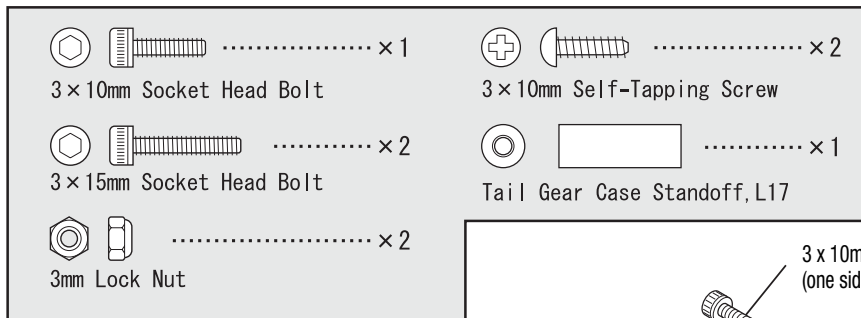





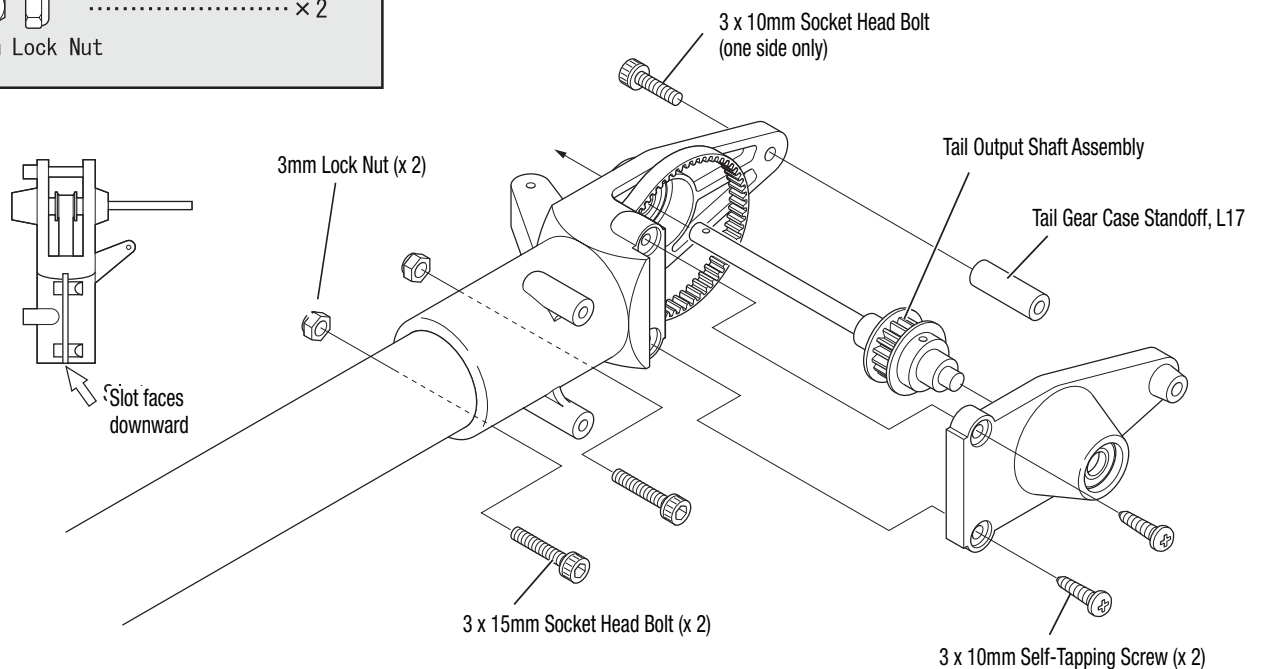



IMPORTANT!

When installing the tail output shaft assembly into the tail gear case, be sure to pass the tail output shaft through the tail drive belt. Tail gear case has a slot at the bottom to hold the tail boom more securely. Be careful not to screw down the fixing bolts too tight, otherwise damage could result. The slot does not have to be fully shut.



5-3





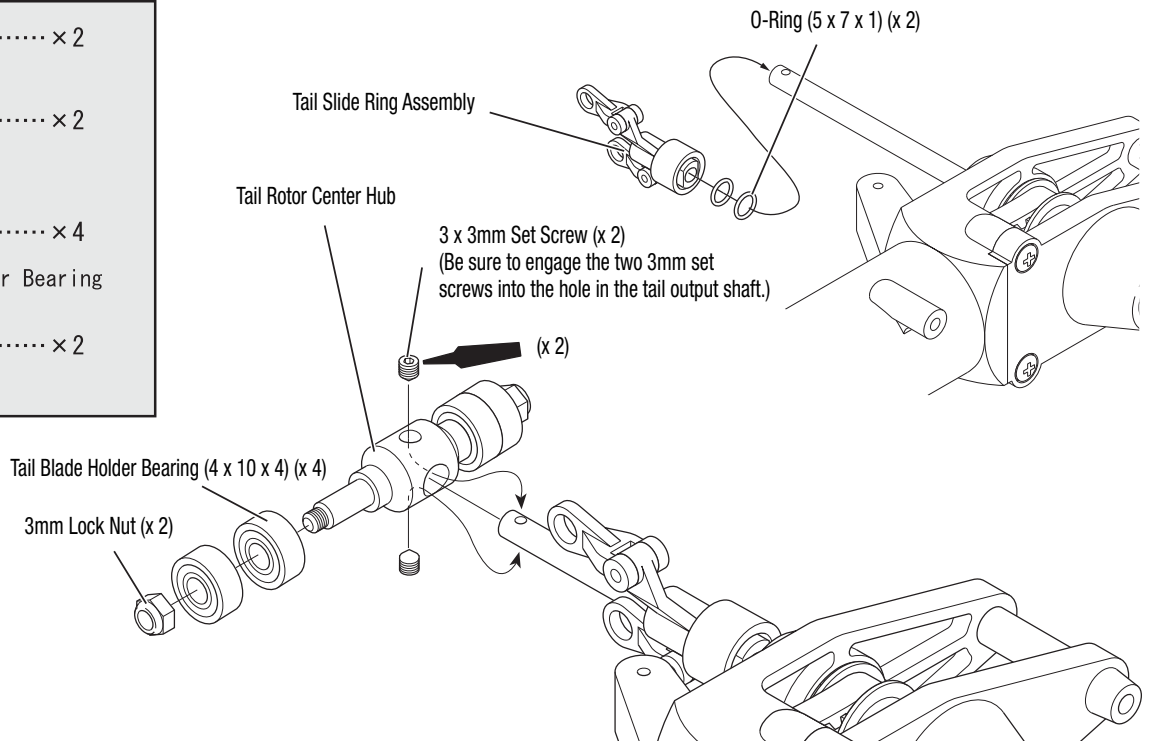
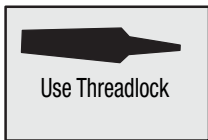



TAIL CENTER HUB ASSEMBLY

-   x 2
3 x 3mm Set Screw
-   x 2
3mm Lock Nut
-   x 4
Tail Blade Holder Bearing (4 x 10 x 4)
-   x 2
O-Ring (5 x 7 x 1)



5-4

TAIL BLADE HOLDER ASSEMBLY

-   x 4
2 x 10mm Socket Head Bolt
-   x 2
3 x 15mm Socket Head Bolt
-   x 4
2mm Hex Nut
-   x 2
3mm Lock Nut

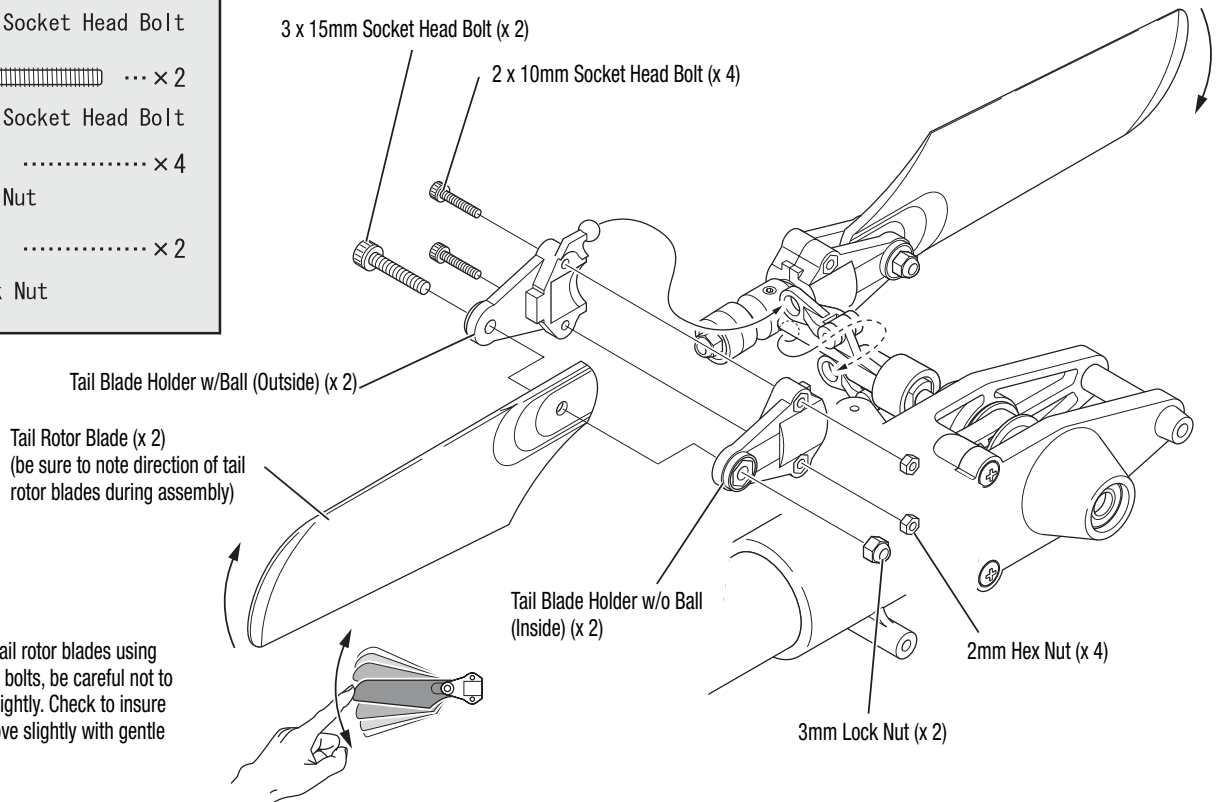





IMPORTANT!

When assembling the tail rotor blades using 3 x 15mm socket head bolts, be careful not to screw them down too tightly. Check to insure the tail rotor blades move slightly with gentle finger pressure.

5-5



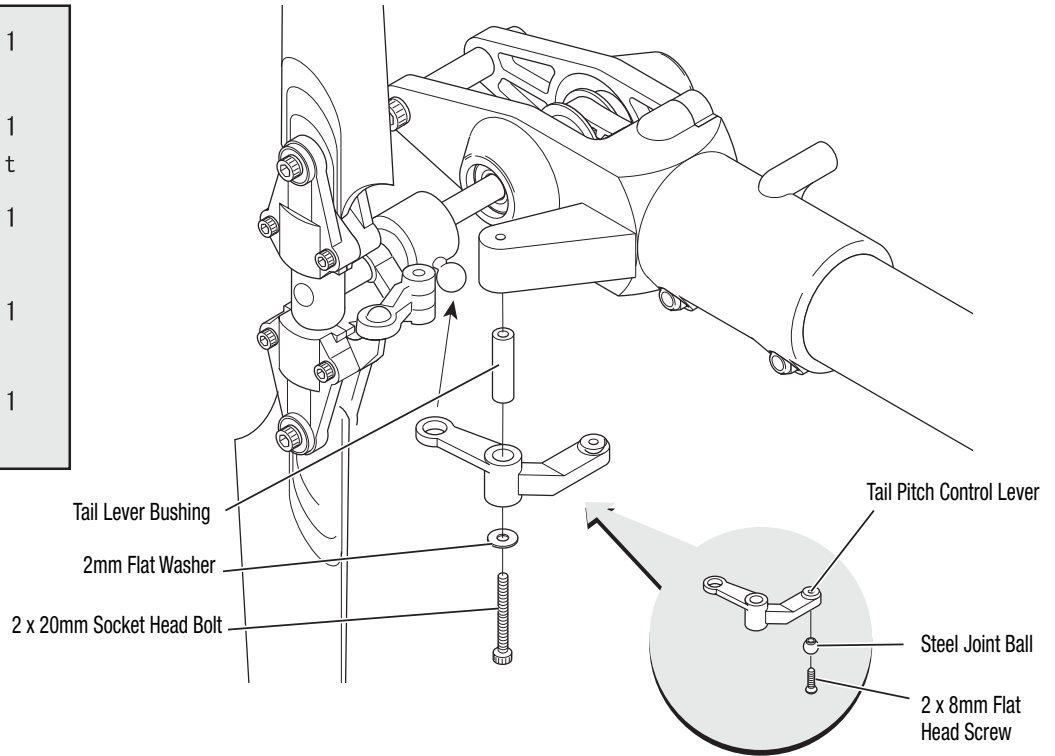

TAIL PITCH CONTROL LEVER INSTALLATION

-  × 1
2 × 8mm Flat Head Screw
-  × 1
2 × 20mm Socket Head Bolt
-  × 1
Steel Joint Ball
-  × 1
2mm Flat Washer
-  × 1
Tail Lever Bushing



5-6

TAIL FIN ATTACHMENT

-  × 1
2.6 × 8mm Self-Tapping Screw
-  × 1
3 × 12mm Self-Tapping Screw
-  × 1
3 × 14mm Self-Tapping Screw
-  × 1
3 × 18mm Socket Head Bolt
-  × 2
Washer (5 × 7 × 0.05)

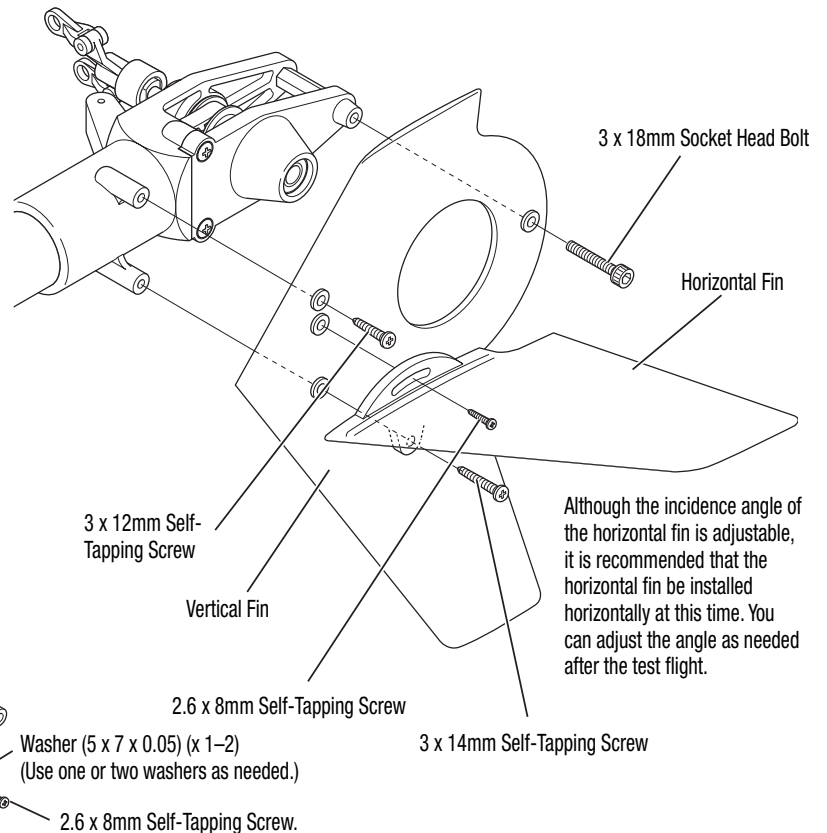

IMPORTANT!

If the tail output shaft moves in the direction shown by the arrow, use one or two washers as needed until the tail output shaft doesn't move.

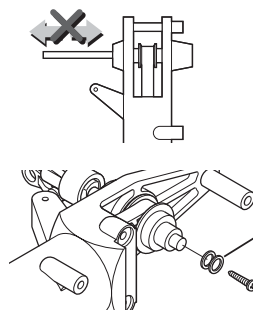

Although the incidence angle of the horizontal fin is adjustable, it is recommended that the horizontal fin be installed horizontally at this time. You can adjust the angle as needed after the test flight.

5-7

TAIL BOOM HOLDER INSTALLATION

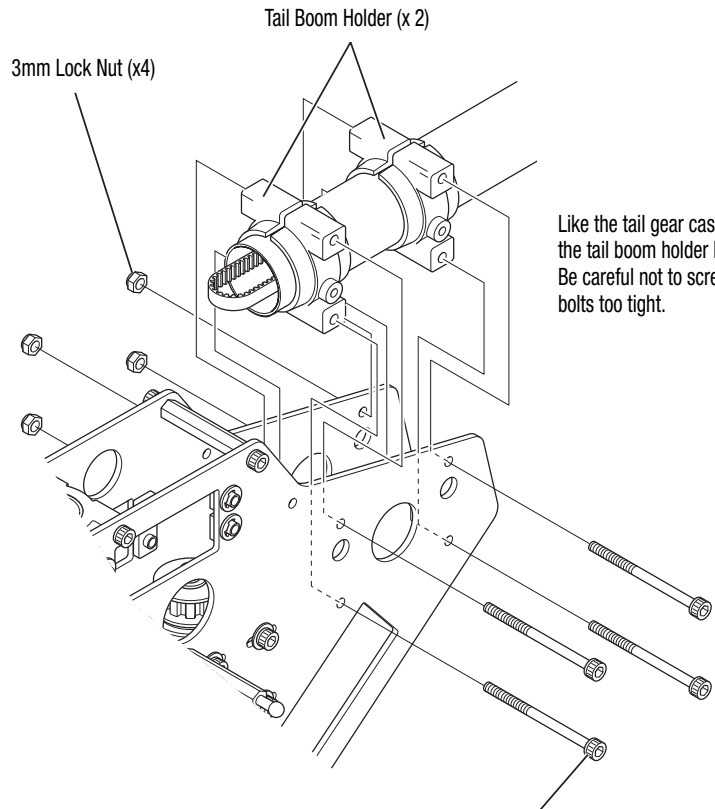
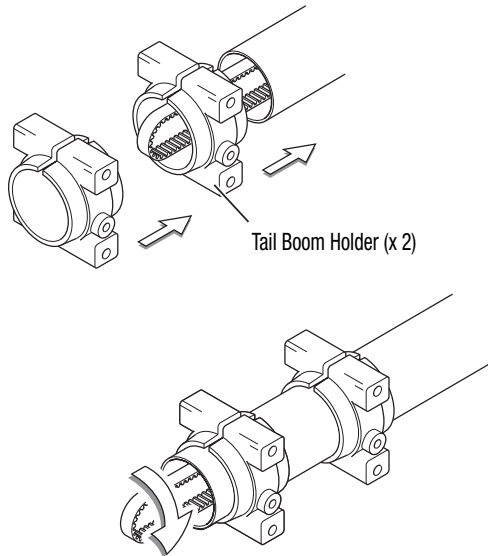
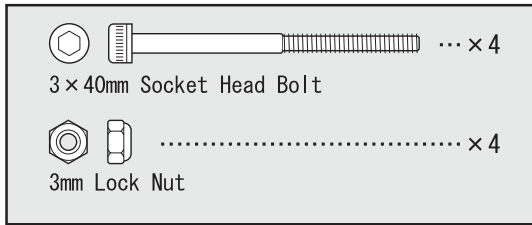

Like the tail gear case (Step 5-2), the tail boom holder has a slot. Be careful not to screw down the bolts too tight.

5-8

TAIL BOOM ASSEMBLY INSTALLATION

IMPORTANT!

- Slide the tail boom through the tail boom holders and engage the tail drive belt over the front pulley. Set the belt tension as per the instructions below.
- Belt tension should be set so that when pressing with your finger, the sides of the belt **do not** come in contact with each other. If unsure, it is always better to set the belt tension too tight than too loose.
- Secure bolts completely after inserting the tail boom, making sure that the tail output shaft is exactly 90° to the main rotor shaft.
- Be certain to note the correct rotation (direction shown below).

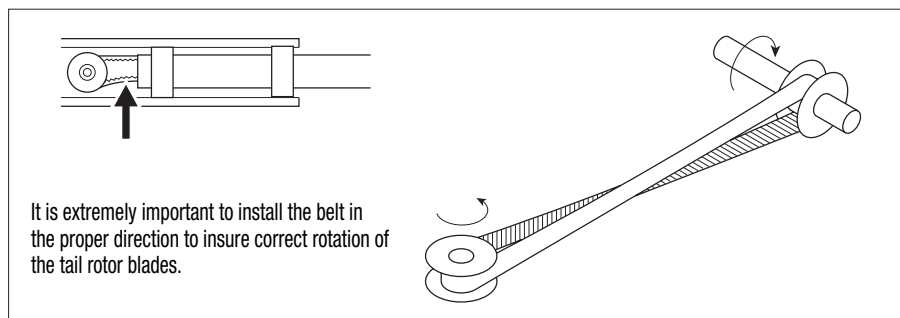
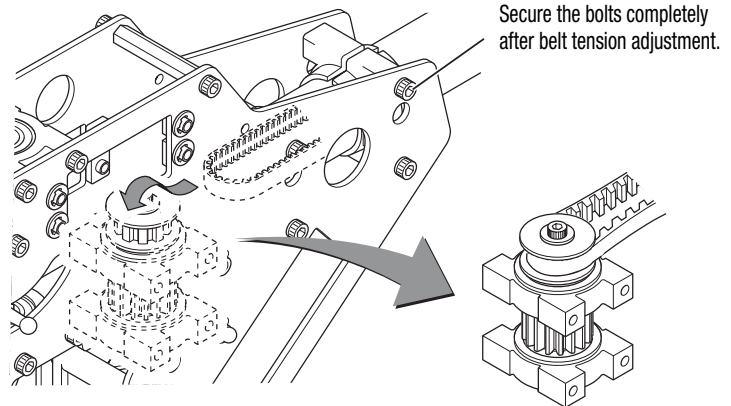

5-9

TAIL BOOM BRACE ASSEMBLY

 × 1
2.6×12mm Socket Head Bolt

 × 1
2.6×15mm Socket Head Bolt

IMPORTANT!

For added boom brace strength, bond the tail brace ends (A) to the tube after assembly using thick CA adhesive.

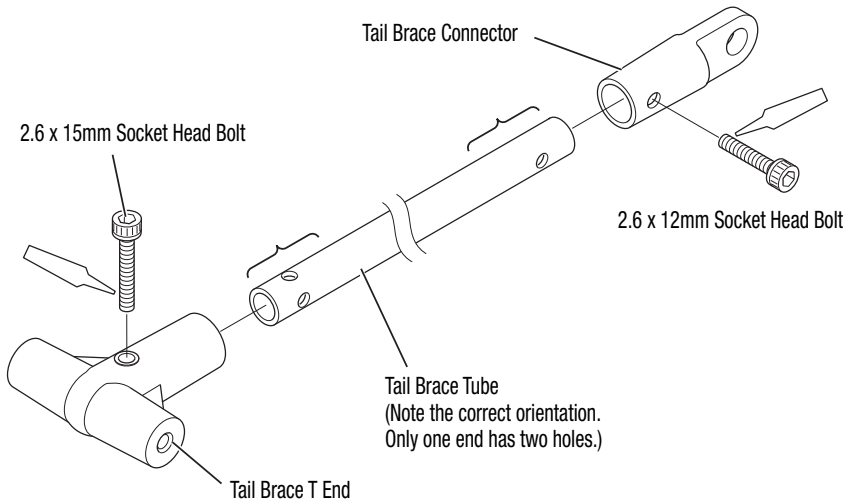

5-10

TAIL BOOM BRACE INSTALLATION

 × 2
3×8mm Socket Head Bolt

 × 2
3×12mm Socket Head Bolt

 × 2
2.6×15mm Socket Head Bolt

 × 2
3mm Lock Nut

 × 2
2.6mm Lock Nut

 × 1
Plastic Spacer (3×7×3)

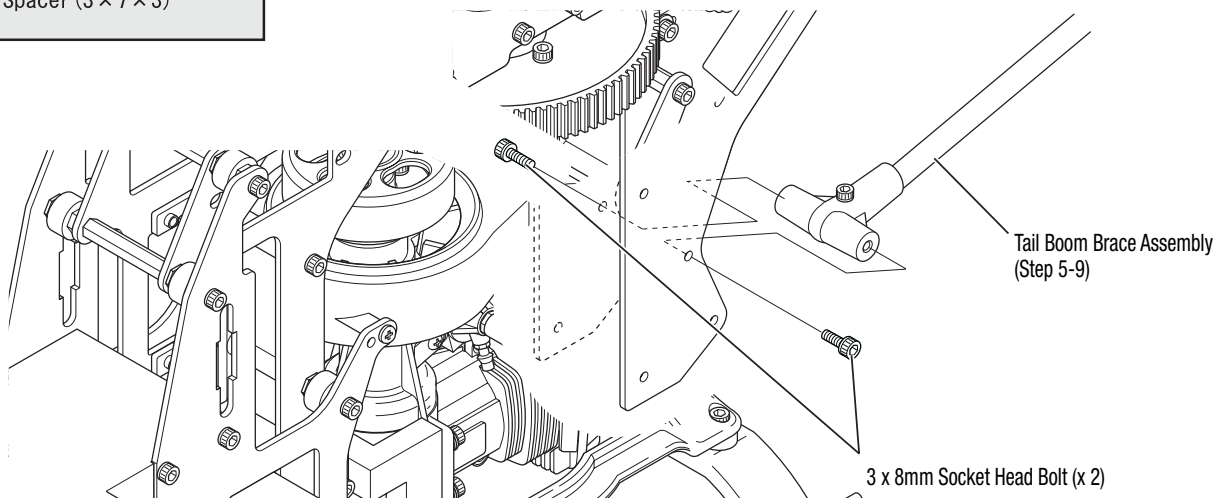
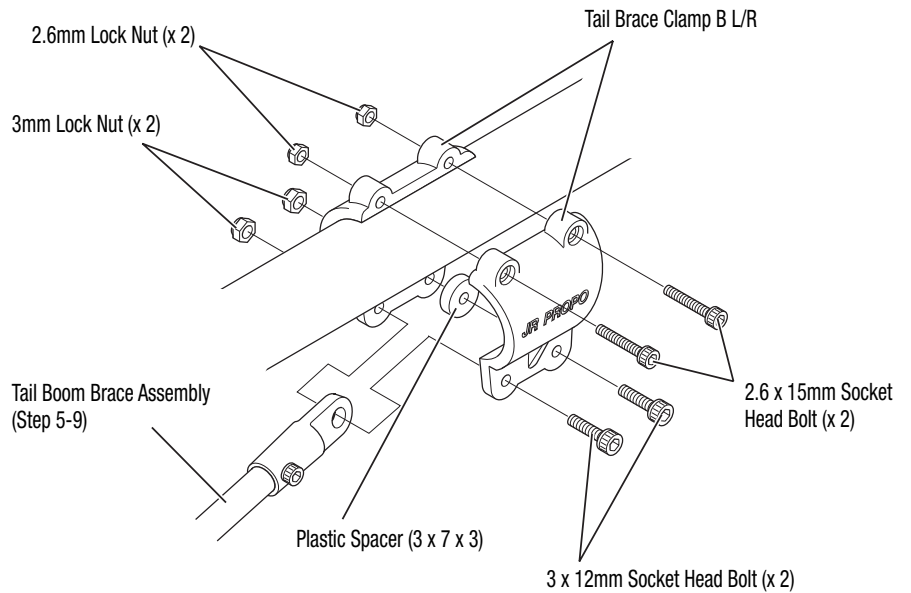

6-1

SERVO INSTALLATION

 × 20
2.6 × 12mm Self-Tapping Screw

 × 20
2.6mm Flat Washer

 × 2
Servo Mounting Plate B

IMPORTANT!

Be sure to install four rubber servo grommets prior to installation. Metal eyelets will not be used. Install the 3 CCPM servos as shown in the diagrams. Install the left and right servos from outside of the frames. When installing the front servo from inside of the frames, fit the servo mounting plate B into the rubber servo grommets prior to installation. Take care not to over-tighten the servo mounting screws. The servos should be able to move slightly within the grommets so that they have a slight amount of vibration absorption. Be sure to note the direction of the servos while installing.

Servo Mounting Plate B (x 2)

Front Servo

Left Servo

2.6 x 23mm Self-Tapping Screw (x 8)

2.6mm Flat Washer (x 8)

Right Servo

Rudder Servo

2.6mm Flat Washer (x 12)

2.6 x 12mm Self-Tapping Screw (x 12)

Throttle Servo

6-2

TAIL CONTROL ROD ASSEMBLY

Set the tail control rod guides and thread links 9mm on to the control rod.

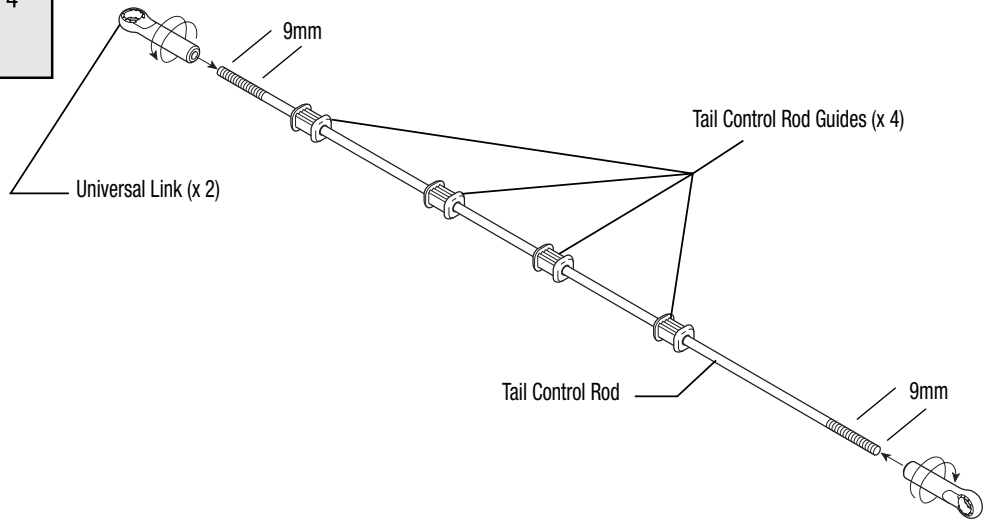

6-3

TAIL CONTROL ROD INSTALLATION



Bend the tail control rod guides to wrap around the tail boom.

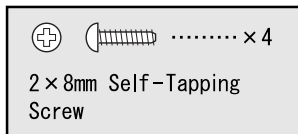
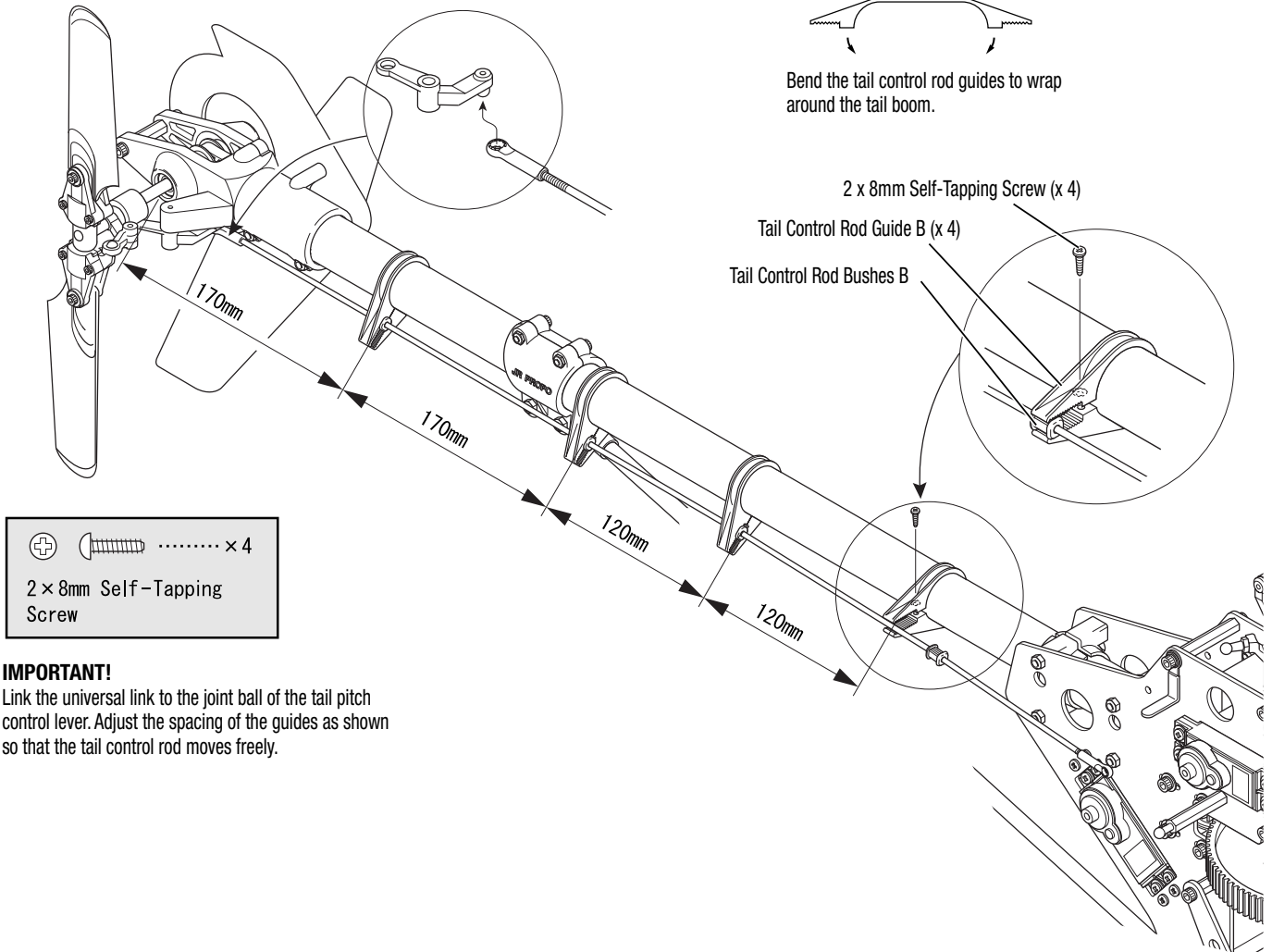

IMPORTANT!

Link the universal link to the joint ball of the tail pitch control lever. Adjust the spacing of the guides as shown so that the tail control rod moves freely.

6-4

GYRO/RECEIVER/SWITCH HARNESS/BATTERY INSTALLATION

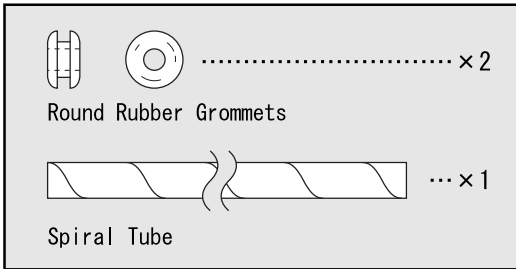

IMPORTANT!

Wrap the servo/gyro lead with the spiral tube to protect them as shown below. Then, fix them with the servo lead holders attached to the frame. It is suggested that both the receiver and gyro amplifier be isolated from vibration by wrapping them in foam, then securing them to the model using double-sided servo tape. Be certain when installing the gyro to the gyro mounting plate that it does not come in contact with the frame of the helicopter and that the mounting surfaces are free from oil, residue etc. Clean if necessary to insure proper adhesion. Install the switch harness with the switch plate screws through the round rubber grommets.

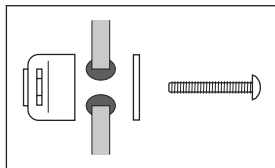
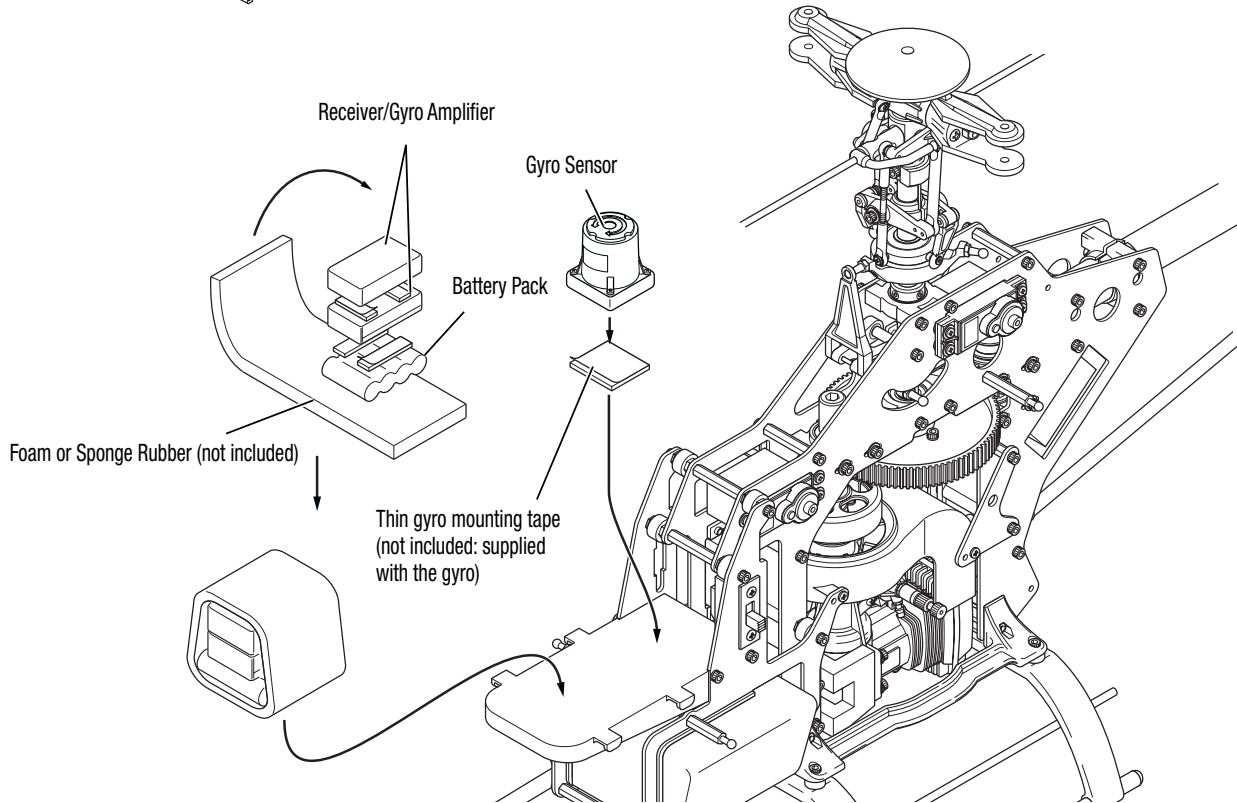
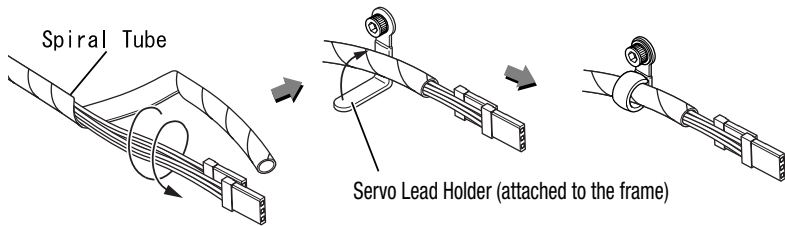

Round Rubber Grommets (x 2)

Switch Plate Screws

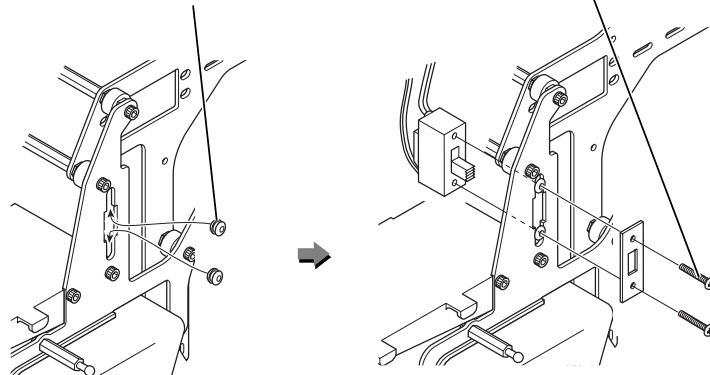

HOW THE JR 120 CCPM WORKS

JR 120° Three-Servo CCPM relies on the radio's special CCPM swashplate mixing, rather than a conventional mechanical mixer that is utilized to achieve the same results.

The radio's 120° Three-Servo CCPM function automatically mixes the three servos to provide the correct mixing inputs for aileron (roll), elevator (pitch), and collective. The following is an example of how each control input affects the servo's movement:

1. Collective

When a collective pitch input is given, all three servos (A, B, and C) move together in the same direction, at equal amounts, to raise and lower the swashplate while keeping the swashplate level. During this function, all three servos travel at the same value (100%) so that the swashplate can remain level during the increase and decrease in pitch. This mixing of the three servos is achieved through the radio's CCPM program.

2. Elevator (Pitch)

When an elevator input is given, all three servos must move to tilt the swashplate fore and aft, but their directions vary. The two rear servos (B and C) move together in the same direction, while the front servo (A) moves in the opposite direction. For example, when an up elevator (back cyclic) command is given, the two rear servos (B and C) will move downward, while the front servo (A) moves upward so that the swashplate will tilt aft. During this function, the front servo (A) travels at 100%, while the two rear servos (B and C) travel at 50% (1/2 the travel value) of the front servo. This difference in travel is necessary due to the fact that the position of the front control ball is two times the distance of the two rear control ball position as measured from the center of the swashplate. As mentioned, this mixing of the three servos is also achieved through the radio's CCPM program.

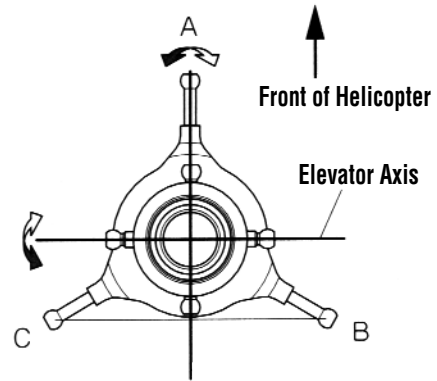

JR 120° CCPM Control System

3. Aileron (Roll)

When an aileron (roll) input is given, the two rear servos (B and C) travel in opposite directions, while the front servo (A) remains motionless. For example, when a left aileron (roll) command is given, the left rear servo (C) will move downward, while the right rear servo (B) will move upward to tilt the swashplate to the left. As mentioned, the front servo (A) will remain motionless. The travel value for each of the two rear servos is 100%.

CCPM SERVO CONNECTIONS

The JR 120° CCPM system requires the use of three servos to operate: aileron, elevator, and AUX 1 (Pitch). The labeling of these servos can become quite confusing because with the CCPM function, the three servos no longer work independently but rather as a team, and their functions are now combined. For this reason, we will refer to the three servos in the following manner:

Aileron Servo: “Left” servo (C); the channel number is CH2 when using a JR radio

Elevator Servo: “Front” servo (A); the channel number is CH3 when using a JR radio

AUX 1 (Pitch) Servo: “Right” servo (B); the channel number is CH6 when using a JR radio

Please refer to the CCPM connections chart below for clarification. For non-JR radios, please consult your radio instructions for proper connection.

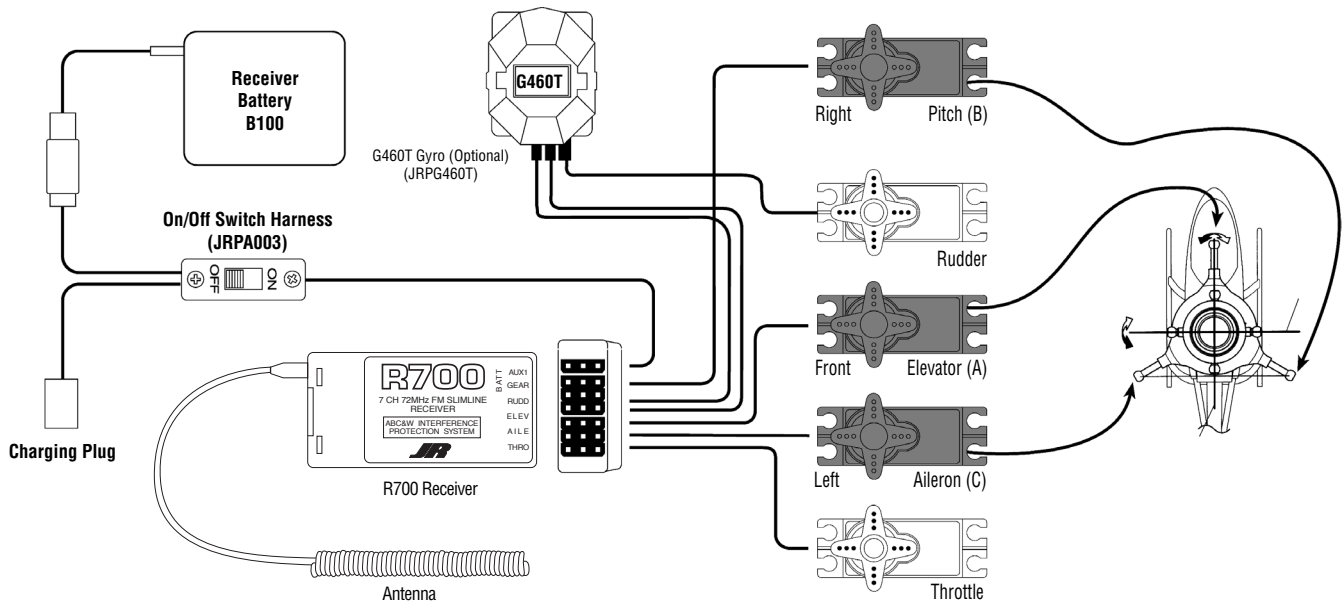

CCPM SOFTWARE ACTIVATION AND INITIAL ADJUSTMENT

The Voyager™ 50 features a CCPM swashplate control system and there are many differences in the settings and adjustments required than for a conventional 90° swashplate system. It is suggested that you first fully understand the features of CCPM before altering any settings. Following are examples of the radio settings for use with the JR PCM10 Series 10, 10S, 10S World Champion model and 10X, XP8103 and XP652/XP662.

Prior to activating the CCPM function, it is first suggested that a Data Reset function be performed to reset the desired mel number to be used back to the factory default settings.

Caution

Prior to performing the Data Reset function, it will be necessary to select the desired model number to be used. Access the Model Select function and select the desired model to be used.

CCPM SOFTWARE ACTIVATION AND INITIAL ADJUSTMENT (CONTINUED)

SETUP PROCEDURE

JR PCM 10 SERIES

The following activation and setup procedure should be used for all JR PCM 10, 10S, 10SX, 10SXII model and 10X systems.

- 1) Access the Data Reset function (Code 28) once the correct model number has been established. Next, press the *CLEAR* key to reset the current model. Press *ENTER* key to exit the Data Reset function. (This procedure should also be performed if using a brand new radio system).
- 2) Access the Swash Type function (Code 65). Next, press the *SEL* key until "3 SERVOS(120°)" appear on the screen. Once this is completed, it will be necessary to change the value to the Pitch function from the factory default setting of +60, to value of -50 using the (-) key below the pitch value. Press *ENTER* to exit the Swash Type function.
- 3) Access the Servo Reversing function (Code 11). Next reverse channel 1, 2 and 4 by pressing the desired channel number. The screen should appear as shown. Press *ENTER* to exit the Servo Reversing function.

- 4) Access the Travel Adjust function (Code 12) and adjust the servo travel values as shown. Please note that the required travel values will vary based on the type of servo selected. Press *ENTER* to exit the Travel Adjust function.

Press the *CLEAR* key to reset.

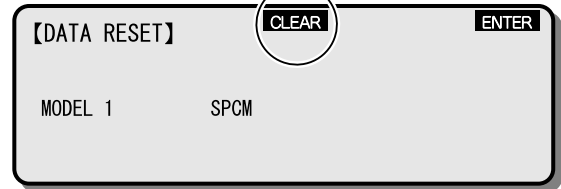

Be sure to select "3 SERVOS(120°)".

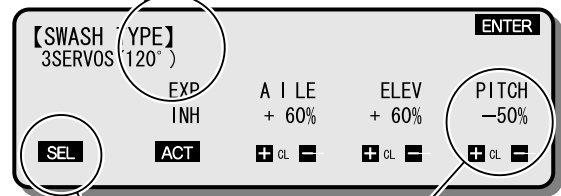

Press the *SEL* key until "3 SERVOS (120°)" appear on screen.

Adjust Pitch value to -50%.

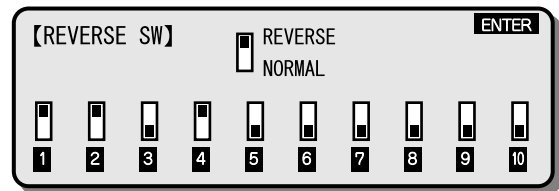

Standard or Digital Servos

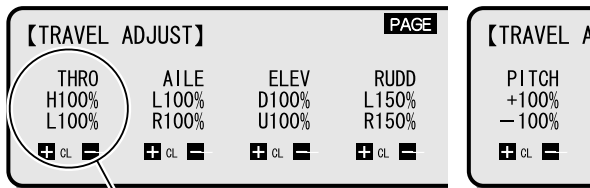

The values are for OS 46FX-H (throttle travel value may vary depending upon engine used).

CCPM SOFTWARE ACTIVATION AND INITIAL ADJUSTMENT(CONTINUED)

XP8103 SYSTEMS

The following activation and setup procedure should be used for the JR XP8103 system.

- 1) Press the *UP* and *DOWN* keys simultaneously while turning the power switch on to enter the System mode. Next, press the *UP* key three times to move the cursor to the Model Reset and press the *UP* and *DOWN* keys simultaneously again to enter the Model Reset function. Be sure to confirm that you need to reset the data of the currently indicated model. Press the *CLEAR* key to rest the current model to the factory default settings. (This procedure should also be performed if using a brand new radio system.)

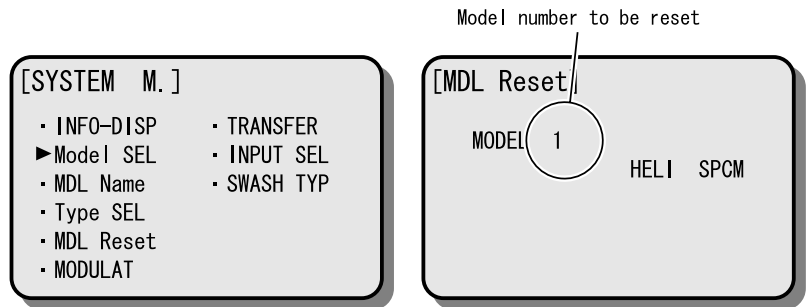

- 2) From the previous Model Reset screen, press the *UP* key four times to access the Swash Type function, then press the (+) key twice to display the "3 SERVOS 120°". Press the *UP* and *DOWN* keys simultaneously to exit the Swash Type function.

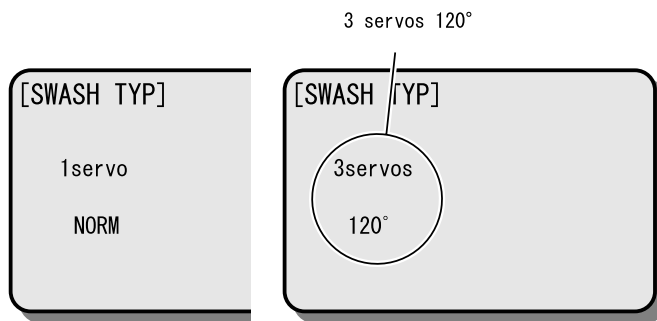

- 3) With the power switch on, press the *UP* and *DOWN* keys simultaneously to enter the Function mode. Press the *UP* key until "Swash Mix" appears on the screen. Once this has been completed it will be necessary to change the value of the Pitch function from the factory default setting of 60 to a value of -50 using the (-) key.

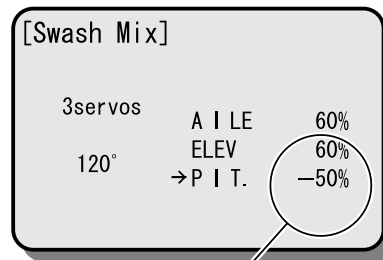

- 4) Press the *UP* key until "REV.SW.(Servo Reversing)" appears on the screen. Next, reverse channels 1, 2 and 4 by moving the cursor with the *CH* key, then press the (+) or (-) keys.

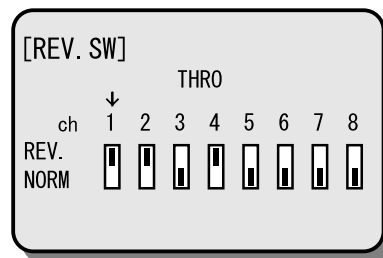

- 5) Press the *UP* key until "TRVL.ADJ." (Travel Adjust) appears on the screen. Adjust the values as shown using the channel key to move the cursor, and the (+) and (-) keys to set the value. Press the *SEL* key to access the pitch channel values and set as indicated. Please note that the required travel values will vary based on the type of servo selected. Please also note that the throttle travel values may vary based on the type of engine used. This value can be fine tuned once the throttle linkage has been installed.

JR Standard and Digital Servos

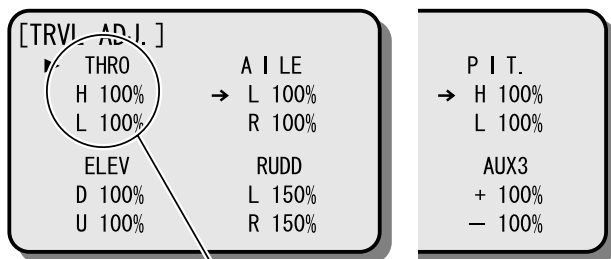

The values are for OS 46FX-H

CCPM SOFTWARE ACTIVATION AND INITIAL ADJUSTMENT(CONTINUED)

JR XP652/XP662

The following activation and set-up procedure should be used for JR XP652/XP662.

- 1) Press the *MODE* and *CHANNEL* keys simultaneously while turning the power switch on to enter the System mode. "TYPE HE" should appear on the screen. If "TYPE AC" appears, press (+) or (-) key until "TYPE HE" appears on the screen. Press the *MODE* key until "RST HE" appears on the screen. Next, press the (+) and (-) keys simultaneously to reset the current model. (This procedure should also be performed if using a brand new radio system.) Press the *MODE* and *CHANNEL* keys simultaneously to exit the System mode.

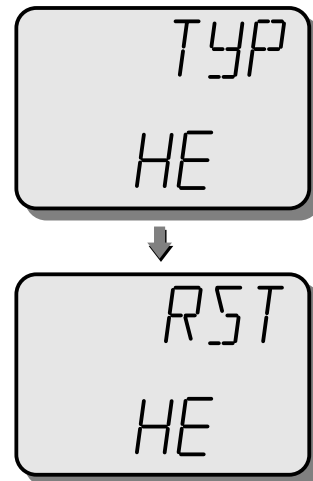

- 2) With the power switch still on, press the *MODE* and *CHANNEL* keys simultaneously to enter the Function mode. Press the *MODE* key until "MIX CCP OF" appears on the screen. Press the (+) or (-) keys to activate the CCPM function. "MIX CP2 +60%" should appear on the screen. Next, press the *CHANNEL* key until "MIX CP6 +60%" appears on the screen. It will be necessary to change the value of CP6 from +60% to -50% using the (-) key. Press the *CHANNEL* key again to confirm that "MIX CCP ON" appears on the screen. Adjust the value to -50%.

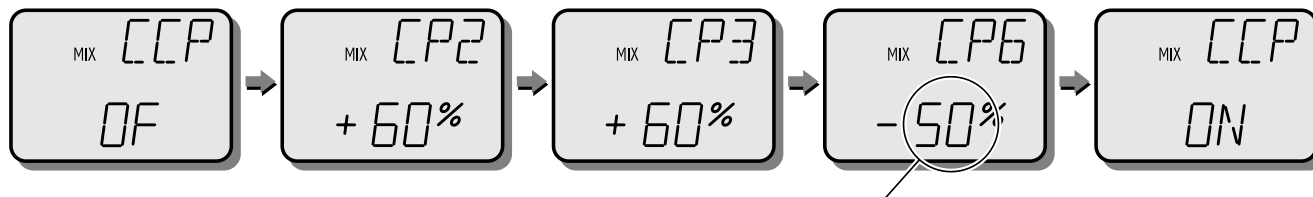

- 3) Press the *MODE* key until the servo reversing screen appears on the screen. "AIL REV*NORM" should appear on the screen. Next, reverse the AIL, RUD, THR channels by pressing the *CH* key to select the desired channel, and then the (+) or (-) keys to set the servo direction.

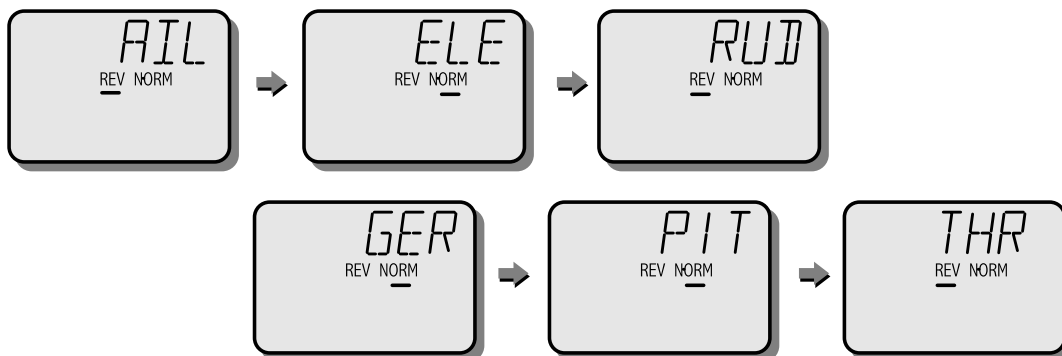

- 4) Press the *MODE* key until "TRV ADJ" (Travel Adjust) appears on the screen and adjust the travel values as shown by pressing the *CHANNEL* key to select the desired channel, and then the (+) or (-) key to set the desired travel value. Move the stick in the opposite direction to adjust the travel in the opposite direction.

JR Standard and Digital Servos

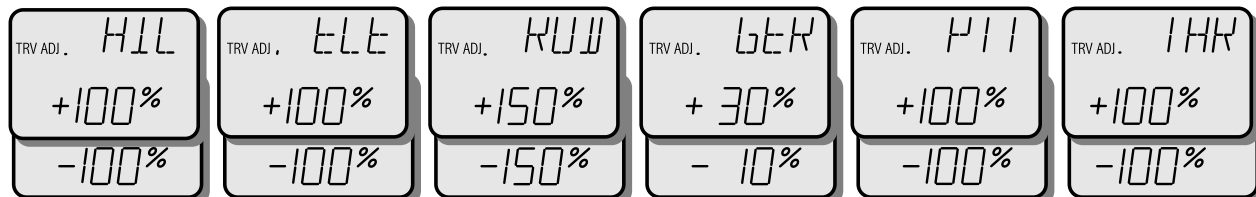

CCPM SOFTWARE ACTIVATION AND INITIAL ADJUSTMENT (CONTINUED)

JR X-378 SYSTEMS

The following activation and setup procedures should be used for all JR X-378 systems.

Prior to activating the CCPM function, it is first suggested that the Data Reset function be performed to reset the desired model number to be used back to the factory default settings. If you are using a new radio system, proceed to Step B.

Caution: Prior to performing the Data Reset function, it will be necessary to select the desired model number to be used.

- A) Press the *DOWN* and *CHANNEL* keys simultaneously while turning the power switch on to enter the system mode. Next, press the *UP* key until the word “Model” flashes on the top right portion of the screen. Press the (+) or (-) keys to select the desired model number to be used. Press the *UP* key until “RESET” appears on the screen. Next, press the *CLEAR* key to reset the data for this model. A “beep” will be heard and the letters “CL” will flash when the *CLEAR* key is pressed, indicating that the data has been reset successfully.

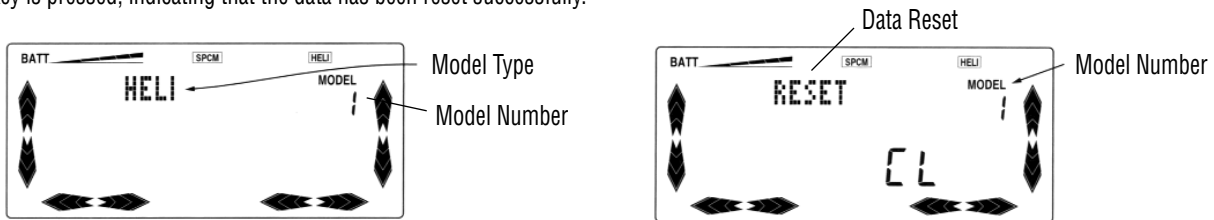

- B) Press the *UP* key until the word “SWASH” appears on the left side of the screen. Next, press the (+) or (-) keys until the word “3SERV” appears on the screen. This would indicate the selection of Three-Servo 120-Degree CCPM. Press the *DOWN* and *CHANNEL* keys simultaneously to store this data and exit the System mode.

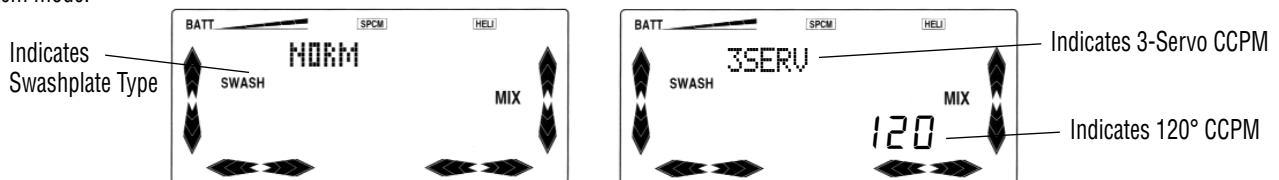

- C) Press the *DOWN* and *CHANNEL* keys simultaneously to enter the Function mode. Next, Press the *UP* or *DOWN* keys until the words “SWASH” and “3S120” appear on the screen. Once at this screen, it will be necessary to change the values for each of the three CCPM channels as shown using the *CHANNEL* key to select the desired channel, and the (+) and (-) keys to alter the values.



- D) Press the *UP* or *DOWN* keys until the word “REV.” appears on the top left portion of the screen. Next, reverse the rudder and pitch channels by using the *CHANNEL* key to select the desired channel and the (+) or (-) keys to change the servo direction from NORM to REV.

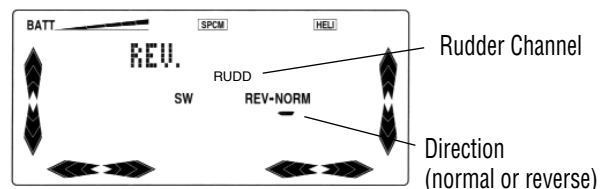



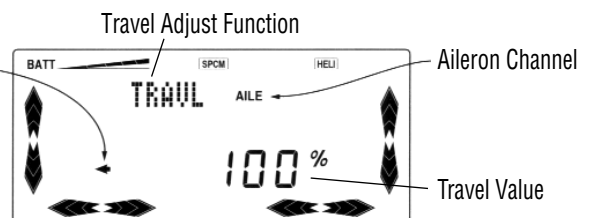



- E) Press the *UP* or *DOWN* keys until the word “TRAVL” appears on the top left portion of the screen. Adjust the servo travel values as shown using the *CHANNEL* key to select the desired channel to be adjusted, and the (+) or (-) keys to increase or decrease the travel value as needed. Please note that the required travel values can vary slightly based on the type of servo selected. Please also note that the throttle travel values may vary based on the type of engine used. This value can be fine tuned once the throttle linkage has been installed.



Note: The travel values shown for the rudder function are for use with Piezo-type gyros like the JR G410T and G460T.

Travel Values: Elevator: 100/100 Pitch: 100/100
Throttle: 120/120 Rudder: 150/150 Aux2: 100/100
Aileron: 100/100 Gear: 100/100

-   ... x 3
2 x 10mm Flat Head Screw
-   x 3
Steel Joint Ball
-   x 3
2mm Hex Nut

SERVO ARM INSTALLATION

It will be necessary to prepare three servo arms as shown in the diagram below. Prior to assembling the servo arms, the servos should be centered as indicated below and the servo arms test fitted to the servo to insure that the arms will attach to the servo as indicated. Since the JR servo arm spline uses an odd number of teeth, it is sometimes possible to rotate the servo arm 180° to achieve a more correct positioning.

Once the best direction for the servo arm has been decided, mark the servo arm with the servo it is to be connected to (F, R or L), as well as the side of the servo arm that needs to be removed. It is very important that a heavy-duty servo arm be used with the control ball location placed at exactly 20mm as shown. If a control ball position other than the specified 20m is used, this will create an adverse affect as to the travel of the swashplate, as well as unwanted control differential and interaction.

Prior to attaching the servo arm to the servo, it will be necessary to first turn on the radio system to center each of the three CCPM servos. It is important that the radio's collective pitch stick be set at the center position. If your radio is equipped with a hover pitch knob, please check to make sure that this knob is also in the center position at this time.

Connect the three servo arms to the three CCPM servos as shown. It is important that the servo arms be positioned parallel to the servos as shown. If the servo arm is not parallel minor centering adjustments can be made using the radio's Sub-Trim function. Please refer to section 7-2 for more information.

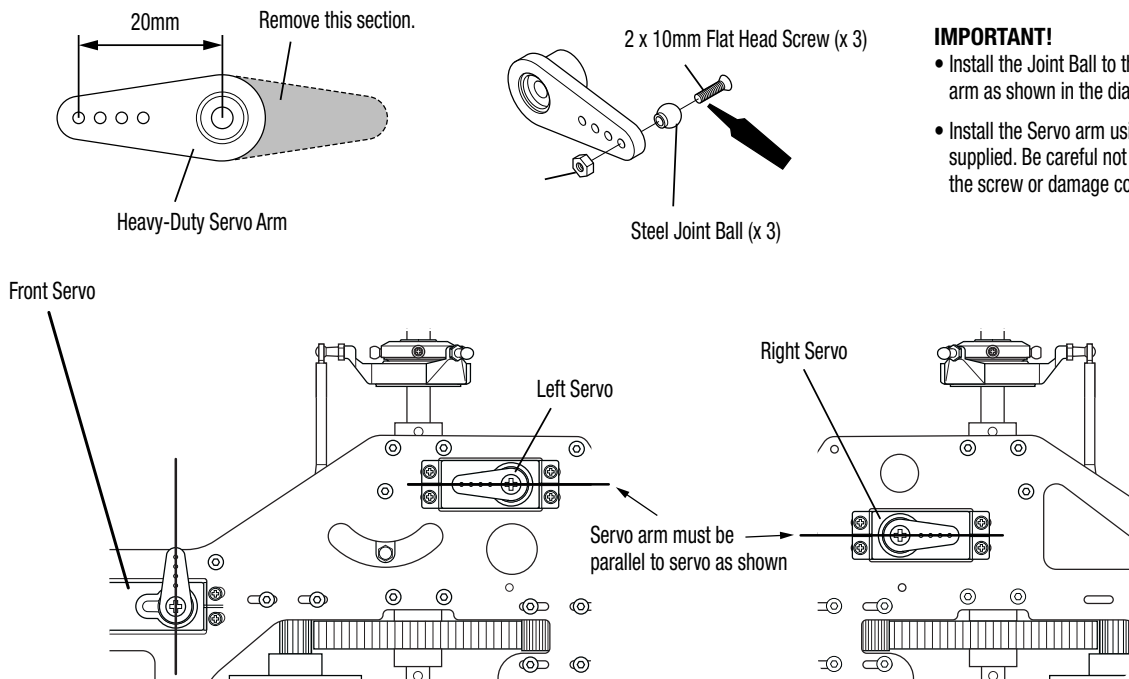

IMPORTANT!

- Install the Joint Ball to the inside of the arm as shown in the diagram at left.
- Install the Servo arm using the screw supplied. Be careful not to over tighten the screw or damage could result.

IMPORTANT!

- Note the correct installation location of the front, right and left servos.
- Install servo arms so that they are parallel to the servos as shown. If the servo arm is not parallel, minor centering adjustments can be made using the radio's Sub-Trim function.

JR XP662

- 1) Enter the Sub-Trim function (Code 15).
- 2) Adjust the left (aileron), right (AUX 1) and front (elevator) servos as needed until the servo arm is exactly parallel to the servo as shown when the collective stick is in the center position. It will be necessary to press the *PAGE* button to access the right servo (AUX 1) sub-trim value.
- 3) Press *ENTER* to exit the Sub-Trim function.

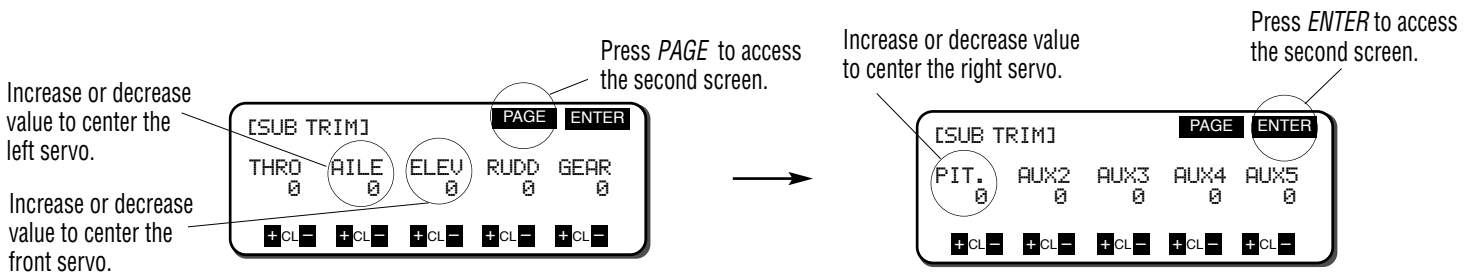
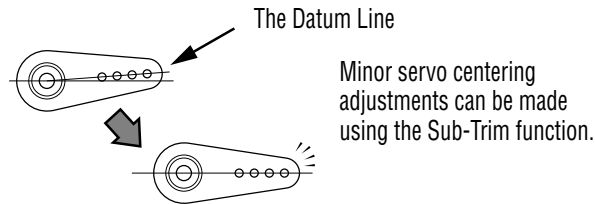

JR XP8103

- 1) With the radio power switch on, press the *UP* and *DOWN* keys simultaneously to enter the Function mode.
- 2) Press the *UP* key until "Sub Trim" appears on the screen.
- 3) Adjust the left (aileron), right (AUX 1), and front (elevator) servos as needed until the servo arm is exactly parallel to the servo as shown when the collective stick is in the center position. It will be necessary to press the *SEL* key once to access the right servo (AUX 1) sub-trim.
- 4) Press the *UP* and *DOWN* keys simultaneously to exit the Function mode.

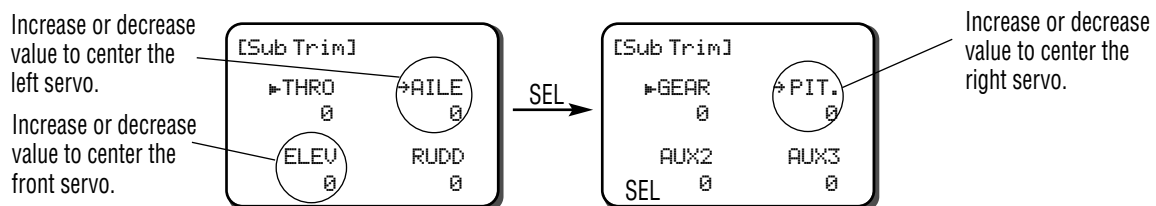

JR XP652/XP662

- 1) With the radio power switch on, press the *MODE* and *CHANNEL* keys simultaneously to enter the Function mode.
- 2) Press the *MODE* key until "SB-TRIM" (sub-trim) appears on the screen.
- 3) Adjust the left (aileron), right (AUX 1), and front (elevator) servos as needed until the servo arm is exactly parallel to the servo as shown when the collective stick is in the center position. It will be necessary to press the *CHANNEL* key to access the necessary channels to be adjusted.
- 4) Press the *MODE* and *CHANNEL* keys simultaneously to exit the Function mode.

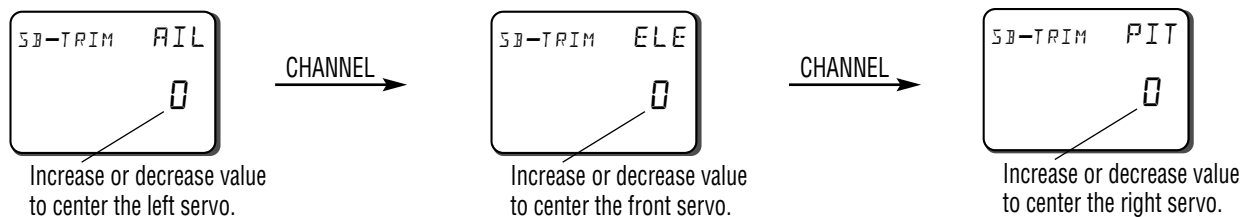

JR X-378

- 1) With the radio power switch on, press the *DOWN* and *CHANNEL* keys simultaneously to enter the Function mode.
- 2) Press the *UP* key until "SUB" appears on the screen.
- 3) Adjust the left (aileron), right (Aux1) and front (elevator) servos as needed until the servo arm is exactly parallel to the servo as shown when the collective stick is in the center position. Use the *CHANNEL* key to select the desired channel to be adjusted, and the (+) and (-) keys to set the sub-trim value for each servo.
- 4) Press the *DOWN* and *CHANNEL* keys simultaneously to exit the Function mode.

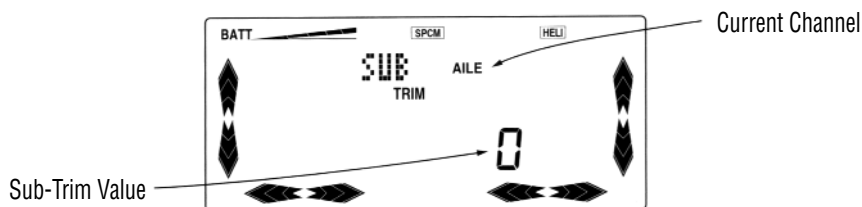

7-3

CCPM LINKAGE CONNECTION

Attach the three CCPM servo linkages as shown below. It is important that the exact distances specified below be maintained for each linkage as this is critical to the alignment and neutral position of the swashplate.

Ⓐ Front Servo to Elevator Arm Linkage
2.3 x 55mm Threaded Rod

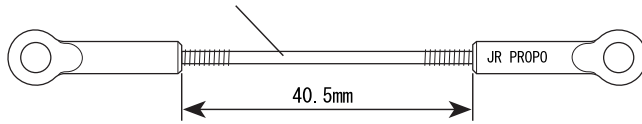

Ⓑ Left Servo to Swashplate Linkage
2.3 x 25mm Threaded Rod

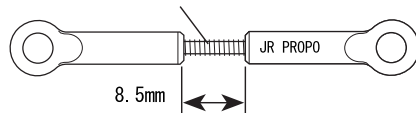

IMPORTANT!

- Please also note the direction of the ball links as shown by the "JR Propo" name imprinted on each ball link. "JR Propo" is imprinted on the front of each ball link. When attaching the control rods, it is important to make sure that "JR Propo" faces outward as the links are attached to the control balls.
- Please also note that when attaching control linkages B and C, it will be necessary to rotate the link that attaches to the swashplate slightly so that it is parallel to the rear mounting surface of the ball link. This will allow the control linkage to rotate slightly on the two control balls.

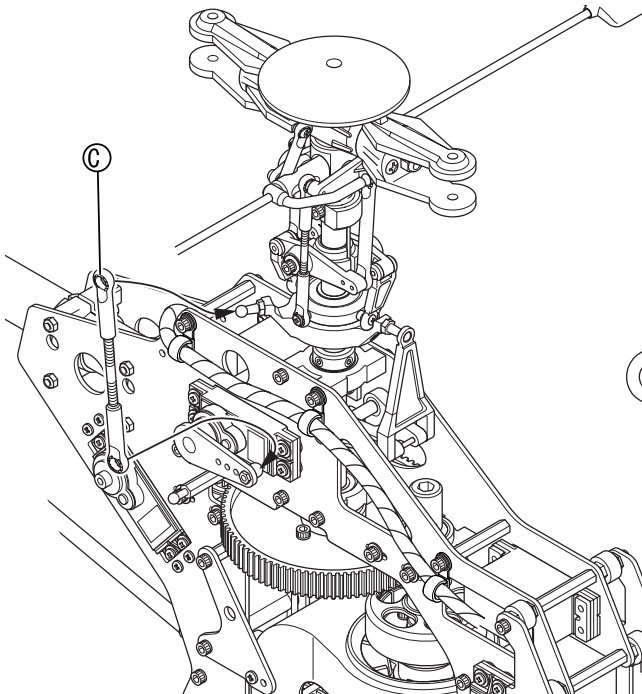
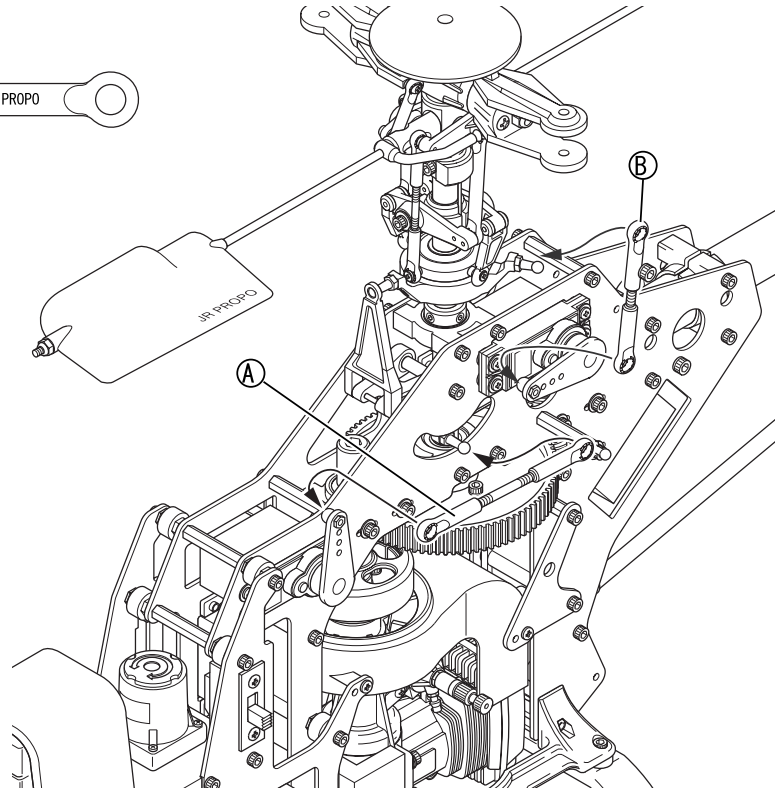

Ⓒ Right Servo to Swashplate Linkage
2.3 x 45mm Threaded Rod

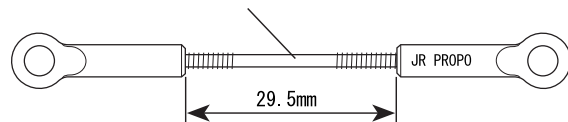

7-4

CHECKING THE SWASHPLATE FOR LEVEL

After the three control linkages have been attached to the swashplate, it will be necessary to check the swashplate to ensure that it is level. To do this, turn on the radio system and place the collective stick in the center position as before. Next, check to make sure that all trim levers and knobs are also in their center position.

Check to insure that the servo arms are parallel to the servos as adjusted in the previous step. If the servos are not parallel, please refer to the Sub-Trim section on page 26 and re-adjust as necessary. Once it's determined that the servo arms are parallel to the servos as required, it will now be necessary to check the swashplate to insure that it is also level or neutral in this position.

It is suggested that the swashplate first be checked from the rear of the model to insure that it's level from left to right. If the swashplate is not level as compared to the frame of the model, adjust either the left or right servo control rod as needed. To determine which rod needs adjustment, it may be helpful to view the swashplate from the left and right side view of the model to determine which side is high or low.

Once this left-to-right adjustment is completed, it will now be necessary to check the fore/aft position of the swashplate to insure that it is also level on this axis. If the swashplate is not level in the fore/aft axis, it is suggested that the adjustment be made to the front servo control linkage as needed. If you are unsure as to which linkage needs adjustment or are having difficulty obtaining the correct adjustment, please check the length of each control rod to insure that it is adjusted to the correct length as outlined in Step 7-3.

Note: If care was taken in the linkage attachment in Step 7-3, little or no adjustment should be required in this step. Only minor adjustments should be made to the lengths of the control linkages at this time. Any major adjustments indicates either incorrect linkage lengths or incorrect servo arm positioning. If the control linkage lengths are altered from the recommended lengths more than one or two turns, this will have a great effect on the range and settings of the collective pitch in later steps.

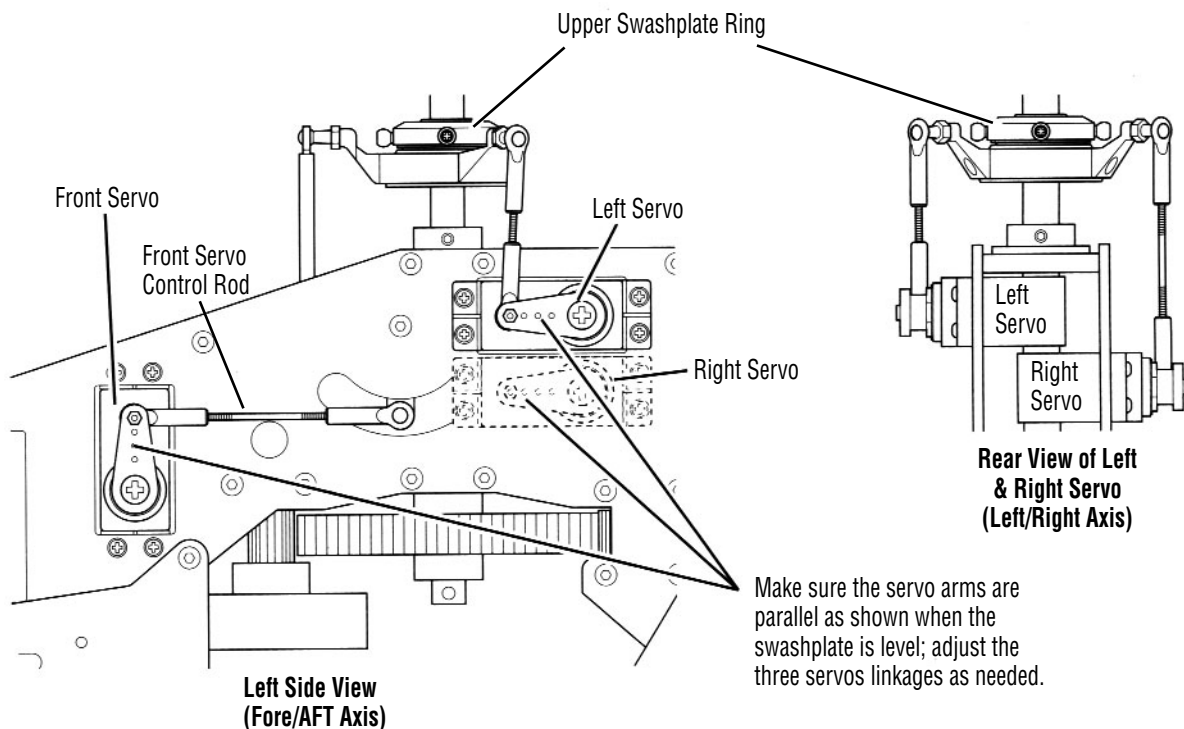

7-5

PITCH-TO-ALLERON MIXING ADJUSTMENT WITH TRAVEL ADJUST

It is very possible that the travel of each servo varies slightly, which can cause the swashplate to be tilted to the left or right when the collective is moved to the extreme high and low pitch positions. This condition is generally more common when standard type servos are used. If JR digital servos are used, the adjustment required is generally very small, if any. These variations in travel can be corrected by altering the travel value of each servo slightly through the Travel Adjustment function.

To check the pitch-to-aileron mixing, it will first be necessary to position the collective stick in the center position as in the previous steps. Next, move the collective stick from the center position to the high pitch position while viewing the swashplate from the rear of the model as shown in the diagram below. While moving the swashplate, look for any tendency for the swashplate to roll to the left or right as it reaches the high pitch position. Repeat this procedure several times to be sure that your observations are correct. If no rolling tendency is found, it will now be necessary to repeat this procedure from the center collective stick position to full low pitch. If no rolling tendency is found, proceed to Step 7-6.

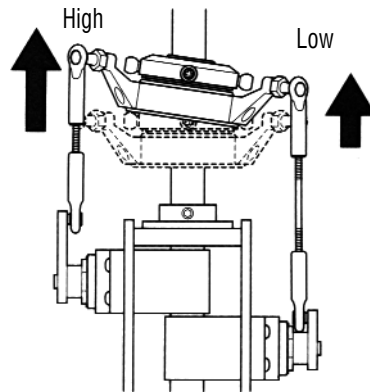

AILE= Left Servo (C)
 ELEV= Front Servo (A)
 AUX1= Right Servo (B)

View is shown from the rear of the model. Notice how in this example, the swashplate has tilted to the right as the collective has moved from center to full high pitch position.

In this condition, we suggest that the travel value for the left servo be reduced slightly (5–10%). Repeat the procedure above. If the same condition occurs, but to a lesser degree, then the travel value of the right servo should be increased slightly and retest. In most cases, it will require only the adjustment of the left or right servo to correct this situation.

For information on the Travel Adjustment function, please refer to your radio instruction manual for details. Once this condition has been corrected, repeat this procedure for the center to low collective pitch position and adjust as needed.

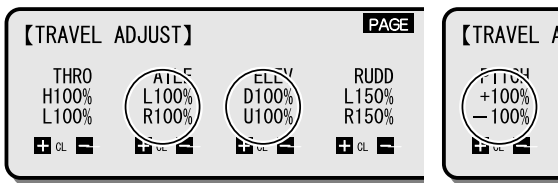

PCM10 Series



XP652/XP662

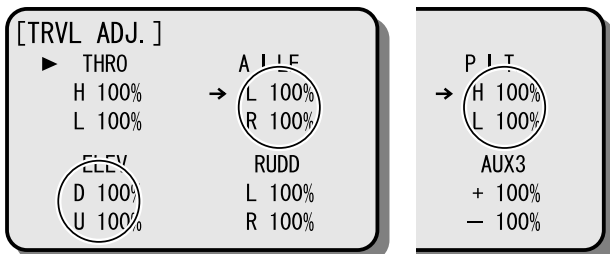

XP8103 Series

IMPORTANT!

Adjust the travel value for the left of right servo as needed until the swashplate is level when the collective stick is moved to its highest position.

The total travel of each servo can vary slightly, which can also cause the swashplate to be tilted fore and aft when the collective is moved to the extreme high and low pitch positions. This situation can also be corrected if necessary through the use of the Travel Adjustment function.

To check pitch-to-elevator mixing, it will first be necessary to position the collective stick in the center position as in the previous steps. Next, move the collective stick from the center to the high pitch position while viewing the swashplate from the left side of the model. While moving the swashplate, look for any tendencies for the swashplate to tilt fore or aft as it reaches the high pitch positions. Repeat this procedure several times to be sure that your observations are correct. If no fore or aft tilting tendencies are found, it will now be necessary to repeat this procedure from the center collective stick position to full low pitch. If no tilting tendency is found, proceed to the next step.

In our example, we have shown that the swashplate has been tilted forward as the collective has been increased to full high pitch. This would indicate that the front servo's maximum travel is now more than that of the two rear servos (left and right).

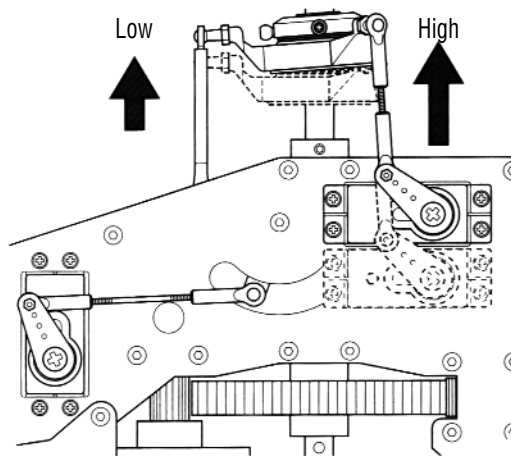

View is shown from the left side of the model. Notice how in this example the swashplate has tilted forward as the collective has moved from the center to the full high pitch position.



In this condition, we suggest that the travel value for the front servo be increased slightly (5–10%). Repeat the above procedure and increase the value as needed until the tilting tendency is eliminated.

For information on the Travel Adjustment function, please refer to your radio instruction manual for details. Once this condition has been corrected, repeat this procedure for the center to low collective pitch position and adjust as needed.

Note: It is very important that during this step, only the travel value for the front servo (elevator) be adjusted to correct any pitch-to-elevator tendencies. If the travel value of the left or right servo changes, this will affect the pitch-to-aileron tendencies corrected in the previous step. If you feel that readjustment of the left and right servo travel is necessary, then it is suggested that the travel for each servo be increased or decreased at the same amount, and the pitch-to-aileron procedure be re-tested.

7-7

TAIL CONTROL ROD SERVO CONNECTION

-  × 1
2 × 8mm Flat Head Screw
-  × 1
Steel Joint Ball
-  × 1
2mm Hex Nut

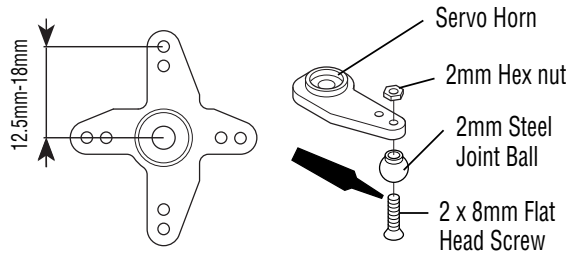

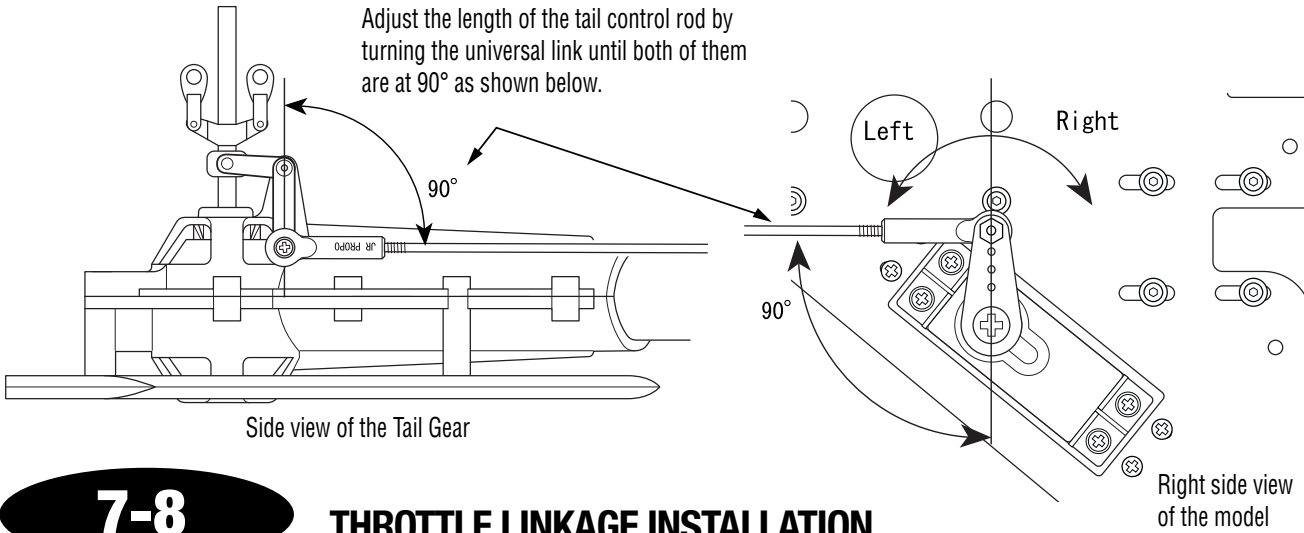

Note: Check to ensure the tail control rod can slide through the tail control rod guides smoothly before connecting it to the servo. If resistance is felt, rotate the tail control rod guides slightly until the control rod slides smoothly. Once the system is adjusted to move freely, it is suggested that a small amount of CA adhesive glue be applied to secure each tail control rod guide to the tail boom in the proper location.



7-8

THROTTLE LINKAGE INSTALLATION

-  × 1
2 × 8mm Flat Head Screw
-  × 1
Steel Joint Ball
-  × 1
2mm Hex Nut

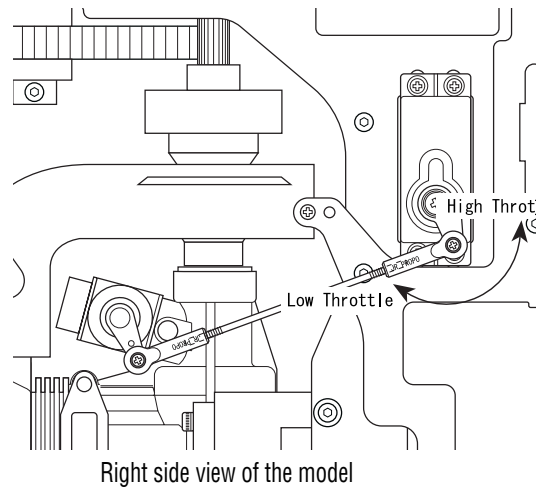
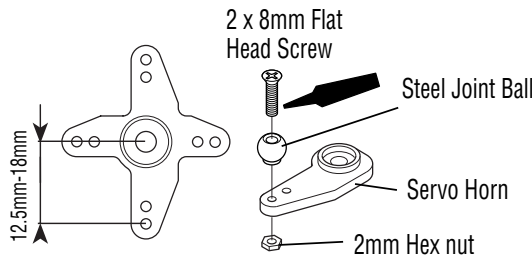

Note

To achieve the correct position of the throttle/servo arm, it may be necessary to re-position the throttle arm on the carburetor and to adjust the length of the throttle linkage slightly to achieve full open and closed positions of the carburetor.

It is also possible to increase/reduce the travel of the throttle servo through the travel adjust function found in most computer radio systems. If this function is used, make sure the values for the high and low positions remain equal (same value for high/low). If these values are not equal, this will create a differential or uneven movement of the throttle, making rotor rpm adjustment and fine tuning more difficult.

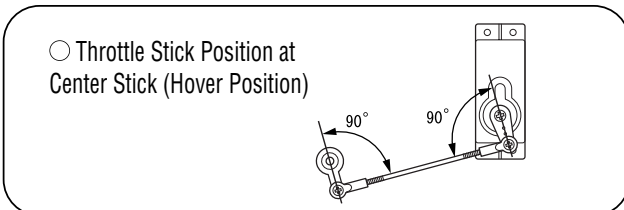
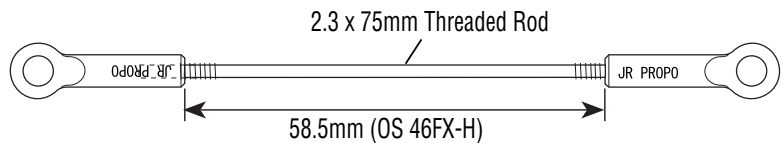

8-1

TRIMMING OF BODY ASSEMBLY

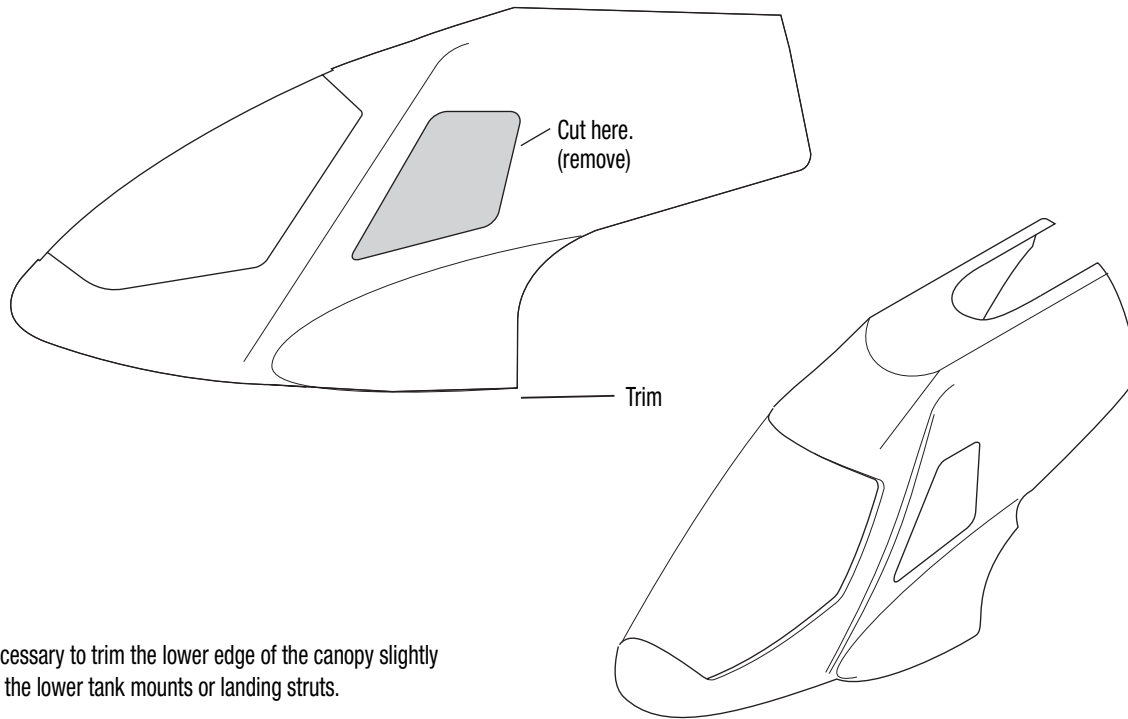

It may be necessary to trim the lower edge of the canopy slightly if it contacts the lower tank mounts or landing struts.

8-2

GROMMET ATTACHMENT

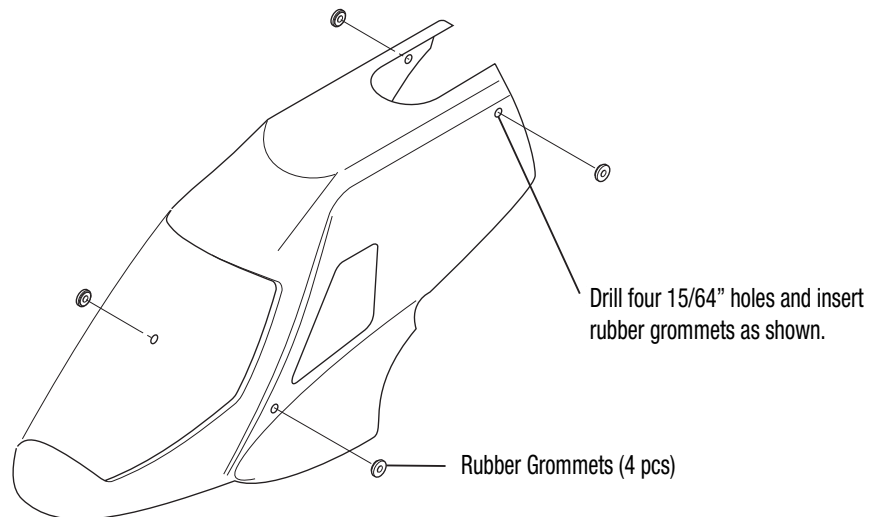
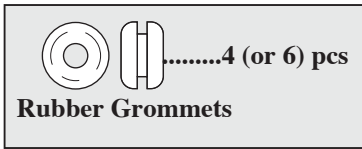

8-3

UPPER MAIN FRAME SECTION ASSEMBLY

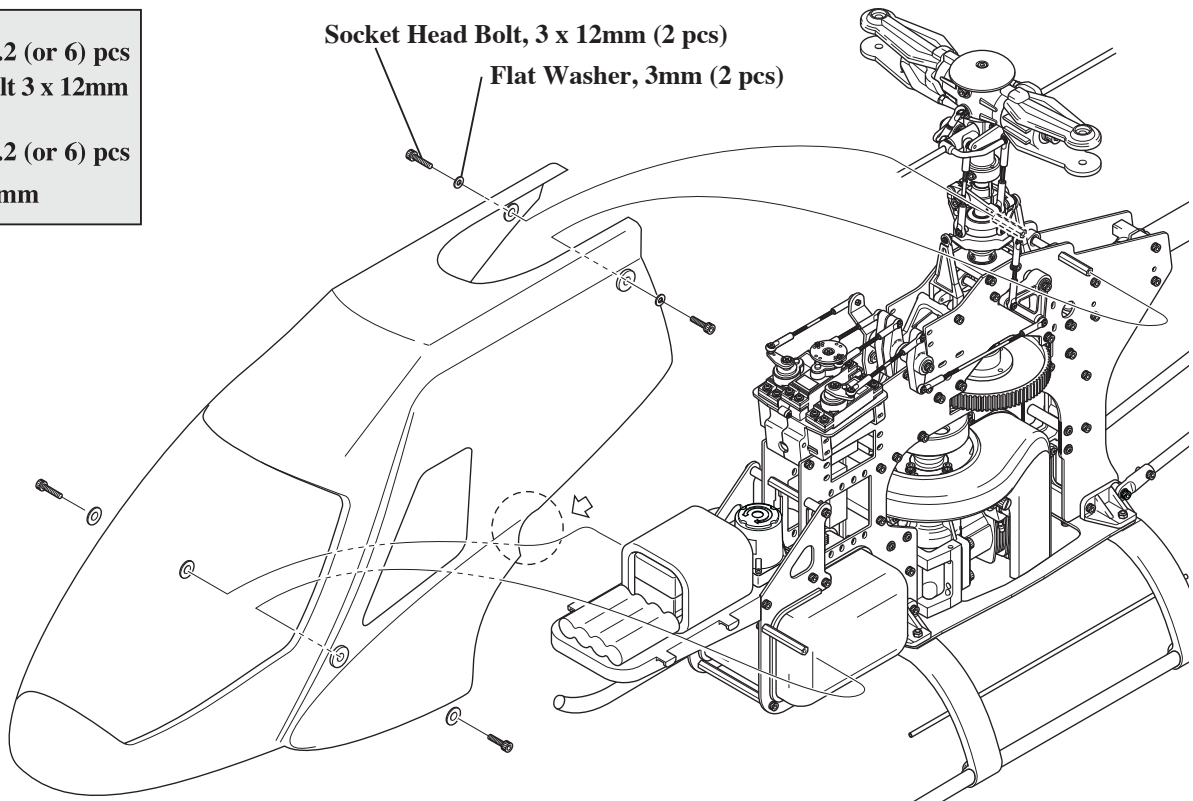
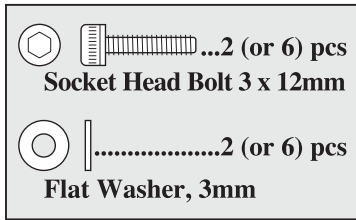

Check to insure the body does not come in contact with any portion of the main frame, muffler, servo, servo horns, etc. Trim for clearance if necessary. Trim and remove a small portion of the canopy shown in the circle above as it is very close to the cooling fan shroud (left side only).

CANOPY PREPARATION AND PAINTING

Before sanding or painting the canopy, clean the canopy by using lacquer thinner or rubbing alcohol to remove any mold release agent that may still be present on the canopy.

Lightly sand the entire canopy using 180 to 220 grit sandpaper or "Scotchbrite" sanding material so that all areas of the canopy have a dull appearance. Clean the canopy again using rubbing alcohol to remove all sanding dust.

Apply a coating of primer to the canopy. Many modelers use a lacquer based automotive primer available in most automotive supply stores.

Once the primer dries, check the canopy for any pinholes that may exist. These pinholes can be spot filled using either an automotive "Glazing" putty or a special pinhole filler like BVM (Bob Violett Models) BVM1925 pinhole filler.

Sand the spot filler and apply a fresh coat of primer. Repeat the filling procedure as needed until all of the pinholes have been filled.

Clean the canopy again to remove any sanding dust and apply your favorite brand of fuel proof paint. Many pilots also use an automotive based paint for color coats, although the automotive paint will need to be sealed using a fuel proof clear coat.

For a quick and attractive paint job, Hangar 9® UltraCote® paint will also work well and is fuel proof for up to 15% nitro (direct fuel contact).

Once the canopy has been painted to the desired finish, apply the decals to the canopy as shown in the following pages.

8-4

MAIN ROTOR BLADE ATTACHMENT

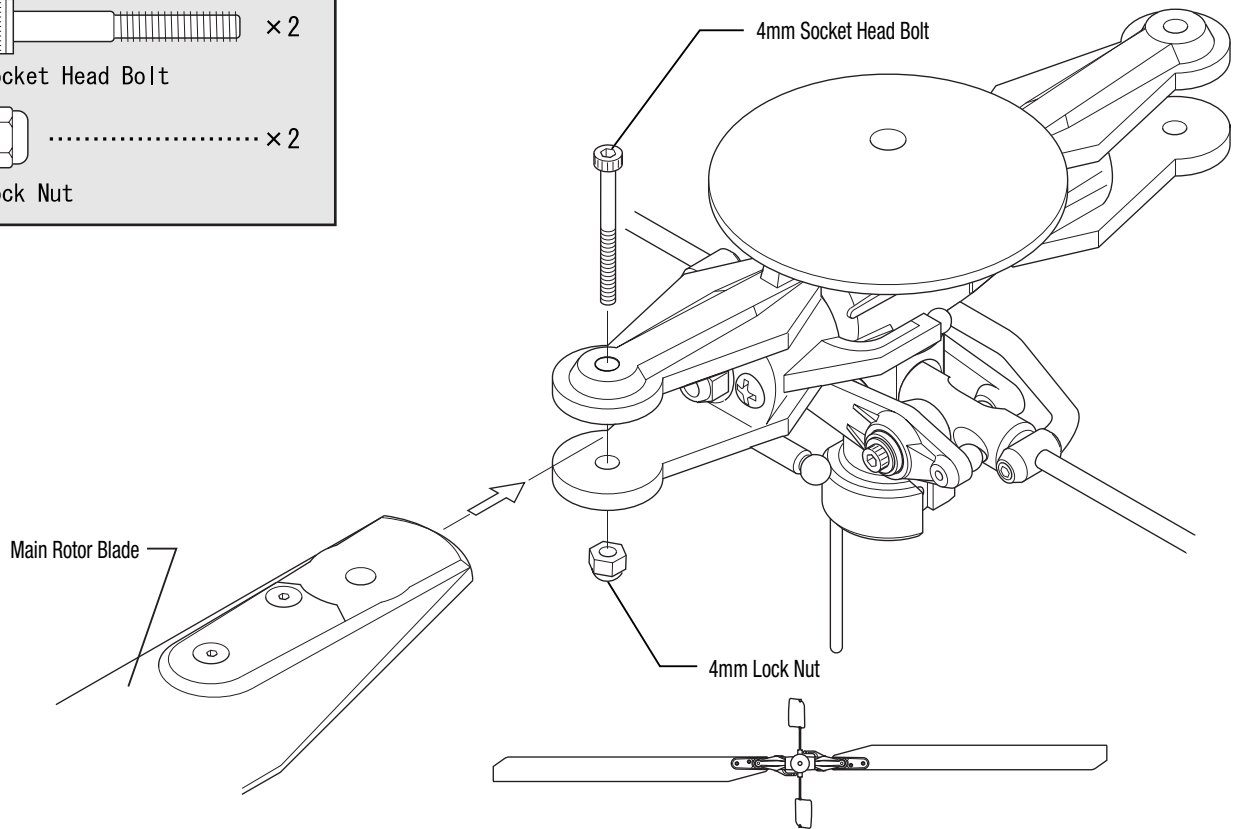
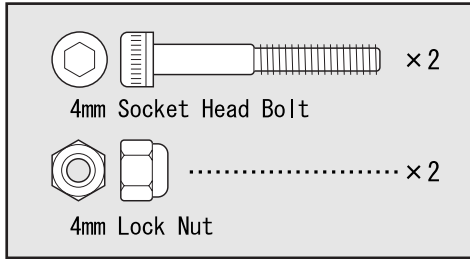

Be certain to note the proper direction of the rotor blades when assembling.

Important!

- Firmly secure the main rotor blades to the rotor head as shown above.
(Rotor blades not included)
- Main blades should be tightened so they can pivot when moderate pressure is applied. Do not allow the main blade to swing freely within the main blade holders.

NOTE

Standard wood 600mm main rotor blades are not recommended and should not be used with the Voyager™ 50.

FINAL SERVO ADJUSTMENT AND RADIO SETUP

Now that the radio system is completely installed into the helicopter, it is necessary to check and adjust the following:

1. Servo Direction (Servo Reversing)

Check to insure that all servos have been set to the correct direction as shown in programming section, pages 33-36.

2. Dual Rates

It is suggested that for initial flights the Dual Rate function values be set as follows:

- 0 Position (low rate): 90%
- 1 Position (high rate): 100%

3. Exponential Settings

Exponential rate settings remain in the 0 value position until the initial test flights. After initial flights, adjust the exponential values to achieve the desired control feel.

4. Sub-Trim Settings

It is suggested that the correct neutral settings be achieved without the use of the sub-trim feature. If sub-trim is used for final flight adjustments, the sub-trim values not exceed 20. If the sub-trim values are greater, readjust the control linkages and reset the sub-trims to 0.

5. Pitch/Throttle Curve Adjustment

It is very important that the throttle and pitch curves are adjusted properly to achieve the best performance from your helicopter. When properly adjusted, the main rotor head rpm should remain consistent throughout all maneuvers and throttle stick positions. A constant rpm will also help to improve the effectiveness and accuracy of the tail rotor and gyro systems.

A. Pitch Curve Adjustment

It will now be necessary to adjust the main rotor blade pitch to match the settings shown in the chart. A main rotor blade pitch gauge (sold separately) will be necessary for this procedure. Prior to setting the main rotor blade pitch, it will be necessary to first set the required blade pitch at 1/2 (center) stick. Turn the system on and set the collective pitch stick to the center position as in previous steps. If all linkages are properly adjusted, the swashplate/rotor head system should appear as shown in the diagram below. Please note that at the center pitch position, the seesaw mixing arms located on the rotor head are parallel (level) to the seesaw shaft/flybar assembly.

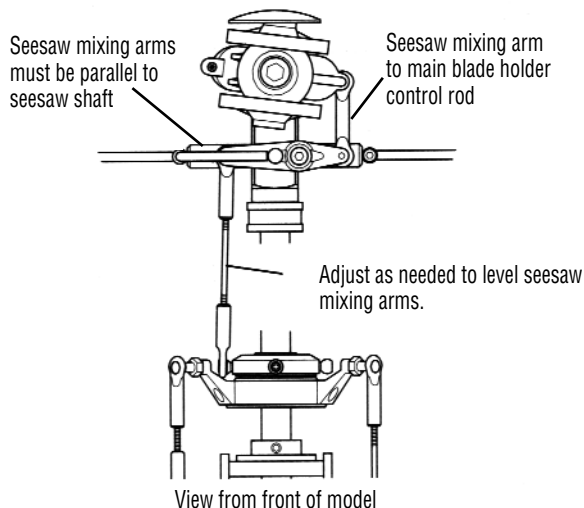

Pitch Range Settings

Flight Mode	Application	Low Pitch (Low Stick)	Hovering Pitch (Half Stick)	High Pitch (High Stick)
N	Hovering	-2°	5°	10°
1	Stunt & Aerobatic Flight	-5°	5°	10°
2	3D Flight	-10°	0°	10°
H	AutoRotation	-5°	5°	13°

Pitch Curve Settings

Hovering (Linear Curve)

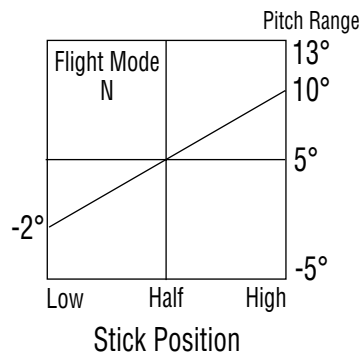

Stunt & Aerobatic Flight

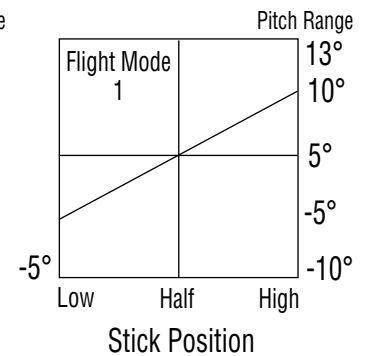

3D Flight

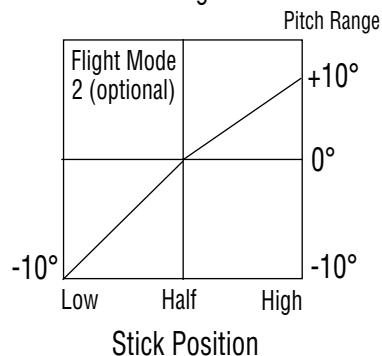

Autoration

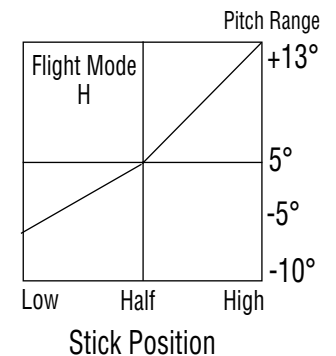

Voyager 50™ Standard Flight

Once the position of the seesaw mixing arms have been established, attach a main rotor pitch gauge (sold separately) to one rotor blade and check the current pitch setting. The current pitch should be approximately +5 at center stick. If the pitch is slightly less or more, this can be adjusted later through the radio's Pitch Curve function. Attach the pitch gauge to the second main rotor blade and match the pitch at this time.

Voyager 50 3D Flight

Once the position of the seesaw mixing arms has been established, attach a main rotor pitch gauge (sold separately) to one rotor blade and check the current pitch setting. Adjust the pitch to the desired setting (0° pitch at center stick) by adjusting the seesaw mixing arm to the main blade holder control rods as shown in Step 4-6. Attach the pitch gauge to the second main rotor blade and match the pitch at this time.

FINAL SERVO ADJUSTMENT AND RADIO SETUP (CONTINUED)

It will now be necessary to establish the maximum pitch value required for your application prior to adjustment. For example, if you are a beginning pilot, then your maximum negative pitch will be -5, and your maximum positive pitch will be +10. The maximum pitch range that you will require will be 15°. If you are a 3D pilot flying the Venture, then your maximum negative pitch will be -10, and your maximum positive pitch will be +10 (+13 for autorotations). The maximum pitch range that you will require will be 23°.

The maximum pitch range mentioned above must be established through the use of the pitch travel value in the CCPM function. Do not try to establish the maximum pitch curve values through adjustment of the Travel Adjustment function, as this will alter the pitch-to-aileron and pitch-to-elevator travel values established in Steps 7-5 and 7-6. Please refer to the CCPM activation section, pages 33–36, for information on how to access the CCPM function.

Once the CCPM function has been activated, set the maximum positive pitch settings as mentioned above. Since the CCPM function does not allow for independent travel settings for positive and negative pitch, it will be necessary to establish the maximum positive pitch, since this is generally the largest degree of pitch in the pitch range. Once the maximum positive pitch range is set, the maximum negative Pitch range can be reduced as needed through the Pitch Curve function.

Set the main rotor pitch gauge to the desired maximum pitch setting, then increase or decrease the CCPM pitch travel (labeled Pitch or Ch6) as needed until this pitch setting is achieved.

XP652/XP662

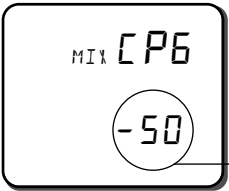

Increase or decrease the value as needed.

X-378

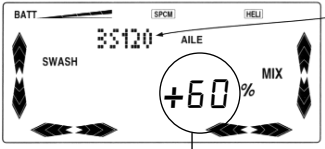

Increase or decrease the value as needed.

PCM 10 Series

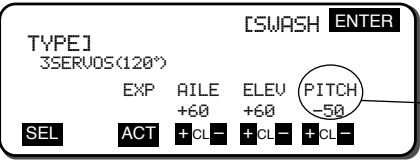

Increase or decrease the value as needed.

XP8103

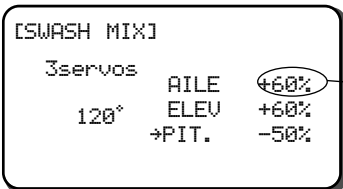

Increase or decrease the value as needed.

B. Throttle Curve Settings

Below are several examples of possible throttle curves during various flight conditions. Since throttle curves can vary greatly due to engine and muffler combinations, it will be necessary to fine tune and adjust these values during test flights to achieve a constant main rotor rpm.

Hovering (Linear Curve)

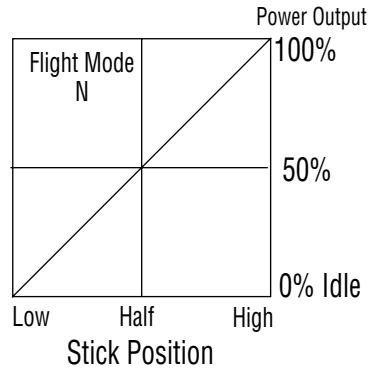

Stunt & Aerobatic Flight

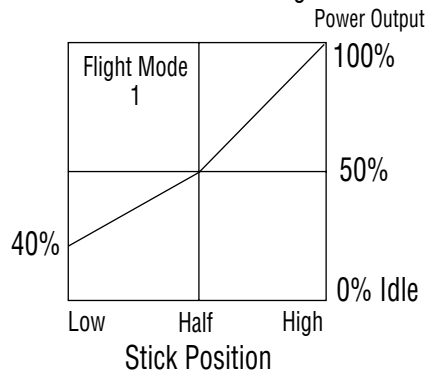

3D Flight (Optional)

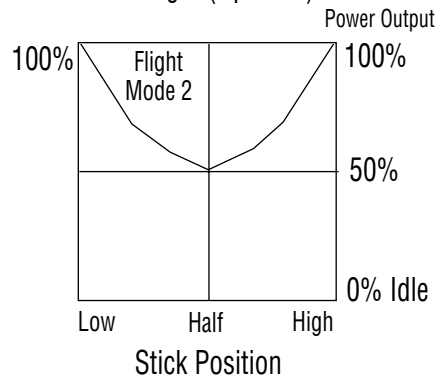

Once this procedure has been completed, the positive and negative pitch settings for each flight mode can be adjusted through the radio's Pitch Curve function. Please refer to your radio's instruction manual for more information.

It will also be necessary to set the correct idle speed of the engine when the Throttle Hold function is activated. This idle value is located within the Throttle Hold function. This will allow the engine to remain at idle when practicing autorotations.

FINAL SERVO ADJUSTMENT AND RADIO SETUP (CONTINUED)

6. Gyro Gain Adjustment (Dual Remote Gain Gyros only)

It will be necessary to adjust the “gain” or compensation of the gyro to create the correct amount of “holding power” necessary for a solid neutral tail rotor. The intent of the gyro is to compensate for abrupt movements, or wind direction changes.

For hovering, it is recommended that you start with the gyro gain at approximately 80% and continue to increase slightly until the tail of the helicopter “hunts,” then reduce the value slightly.

PCM 10 Series Radio with G460T,
G550T, and G5000T Gyros

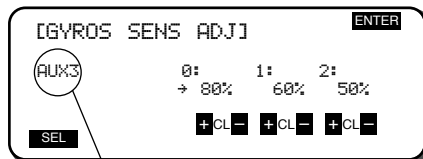

Press *SEL* to select AUX3 or AUTO GAIN function.

XP8103 with G460T, G550T,
and G5000T Gyros

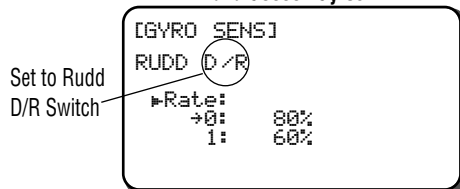

XP652 with G460T, G550T,
and G5000T Gyros

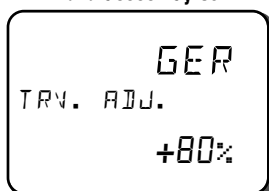

XP652 with G460T, G550T,
and G5000T Gyros

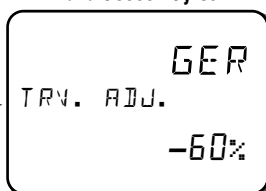

Change
switch
Position

Please refer to your radio's instructions for more information.

This same adjustment will also be necessary to achieve proper forward flight. Generally, the gyro gain for forward flight will be approximately 10%–20% less than that of the established hover gain due to aerodynamic forces present in forward flight. We recommend a 60% value as a good starting position.

7. Verifying Gyro Direction

It will also be necessary to confirm the direction the gyro compensates when the body of the helicopter is rotated.

To do this, turn the radio system on and suspend the helicopter by the main rotor head. Next, move the rudder stick to the right and watch the direction that the tail rotor servo arm travels. Now while watching the tail rotor servo arm, rotate the body of the helicopter counterclockwise. The servo arm should move in the same direction as when the rudder stick was moved to the left. If the arm moves in the opposite direction, reverse the gyro and re-test.

FINAL PREFLIGHT CHECK

Once all assemblies have been completed, please review the following suggestions before attempting initial flights.

- Review the instruction book and confirm that all assembly steps have been completed thoroughly.
- Verify that the tail rotor assembly rotates in the correct direction (see the diagram below).
- Verify that the gyro is operational and compensating in the correct direction (detailed in Step 6, page 50).
- Insure that all servos are operating smoothly and in the correct direction. Also verify that there is no binding in the control rods and that each servo horn is secured with a servo horn mounting screw.
- Make sure that both the transmitter and receiver have been fully charged (refer to your radio system instructions for proper charging procedures).
- Insure that the throttle is working properly and in the correct direction.

Correct Main/Tail Rotor Rotation Direction

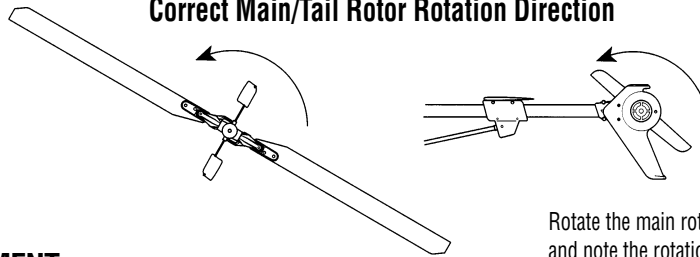

Rotate the main rotor counterclockwise (backward) and note the rotation of the tail rotor.

BLADE TRACKING ADJUSTMENT

Blade tracking is an adjustment to the main rotor blade pitch that must be accomplished during the initial test flights. Although the blade pitch angle in each blade may appear equal, it is still possible for a set of main rotor blades to run “out of track,” making adjustment necessary. Main rotor blades that are out of track with one another can cause vibration, instability, and a loss of power due to additional drag.

On the initial flight, it will be necessary to increase the blade speed to just before lift-off rpm and view the rotor disc at eye level from a safe distance (approximately 15 to 20 feet).

Note which blade is running low (by colored tracking tape) and increase the pitch of the low blade one turn of the ball link at a time until each blade runs in track (on the same plane).

Please refer to the diagrams below to identify the different tracking situations, as well as several methods to mark each rotor blade for tracking identification.

BLADE TRACKING IDENTIFICATION

Out of Track

Incorrect

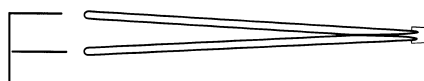

Adjustment is necessary

In Track

Correct

Adjustment is **not** necessary

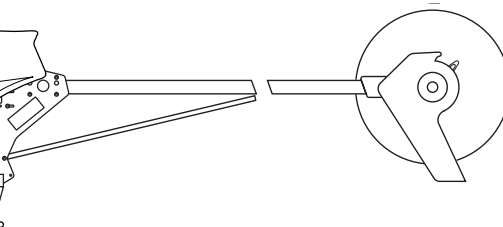

Caution: Be sure to maintain a safe distance from the helicopter (15 to 20 feet) when tracking main rotor blades.

Blade Labeling for Tracking Purposes

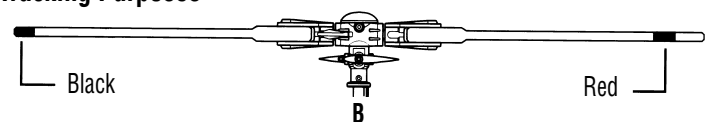
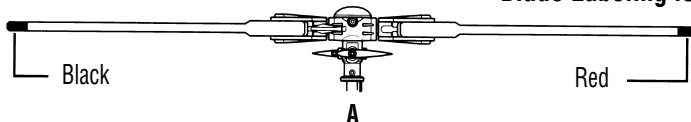

A: Use two different blade tracking tape colors (e.g., black and red) at the tip of each main rotor blade.

B: Use the same color blade tracking tape located at different positions on each rotor blade.

Note: Adding additional blade tracking tape to the rotor blades at this stage will make it necessary to re-static balance the main rotor blades.

XP652/XP662 HELI DATA SHEET VOYAGER™ 50 STANDARD SETUP

Modulation S-PCM • Z-PCM • PPM (FM)

Model Number _____

Model Name Voyager 50 Standard Setup

CHANNEL	THR (1)	AIL (2)	ELE (3)	RUD (4)	GER (5)	PITCH (6)
* REVERSE SW	NORM • REV	NORM • REV	NORM • REV	NORM • REV	NORM • REV	NORM • REV
SUB-TRIM	Adjust as needed					
TRAVEL ADJUST (TRV ADJ.)	Refer to the CCPM section of this manual for proper settings					
FAIL-SAFE (S-PCM)						

FAIL-SAFE TIME (Z-PCM)	
------------------------	--

D/R SW	Factory Preset
--------	----------------

GEAR SW	Factory Preset
---------	----------------

THRO HOLD (HLD)	ON • OFF	POSITION
		± Adjust for Idle

REVO-MIX (RV)	+	UP (U)	Refer to your gyro's instructions for proper settings
	-	DOWN (D)	
HOLD RUDD OFFSET (OFFSET HLD)			±

STUNT TRIM		ON • OFF
AIL (2)	ELE (3)	RUD (4)
+	+	+
-	-	-
Adjust stunt trim values as needed		

			AIL (AI)	ELEV (EL)
DUAL RATE • EXP	POS 0	D/R	90%	90%
		EXP	20%	20%
	POS 1	D/R	100%	100%
		EXP	30%	30%

		L	2	H
THRO CURVE TLN, T2N, THN,	N	0%	50%	100%
TLS, T2S	S	40%	60%	
PITCH CURVE PLN, P2N, PHN,	N	-2° Pitch	5° Pitch	10° Pitch
PLS, P2S, PHS,	S	-5° Pitch	5° Pitch	10° Pitch
PLH, P2H, PHH	H	-5° Pitch	5° Pitch	13° Pitch

CCPM MIXING		ON • OFF
AIL (2) + 60%	ELE (3) + 60%	Pitch (6) + 50%
-	-	-

		CHANNEL MASTER SLAVE	MIX SWITCH	OFFSET	+GAIN	-GAIN
PROG. MIX	A	→	ON • F1 • F0 • H			

TRIM OFFSET	
-------------	--

XP652/XP662 HELI DATA SHEET VOYAGER™ 50 3D SETUP

Modulation S-PCM • Z-PCM • PPM (FM)

Model Number _____

Model Name Voyager 50 3D Setup

CHANNEL	THR (1)	AIL (2)	ELE (3)	RUD (4)	GER (5)	PITCH (6)
* REVERSE SW	NORM • REV	NORM • REV	NORM • REV	NORM • REV	NORM • REV	NORM • REV
SUB-TRIM	Adjust as needed					
TRAVEL ADJUST (TRV ADJ.)	Refer to the CCPM section of this manual for proper settings					
FAIL-SAFE (S-PCM)						

FAIL-SAFE TIME (Z-PCM)	
------------------------	--

D/R SW	Factory Preset
--------	----------------

GEAR SW	Factory Preset
---------	----------------

THRO HOLD (HLD)	ON • OFF	POSITION
		± Adjust for Idle

REVO-MIX (RV)	+	UP (U)	Refer to your gyro's instructions for proper settings
	-	DOWN (D)	
HOLD RUDD OFFSET (OFFSET HLD)			±

STUNT TRIM			ON • OFF
AIL (2)	ELE (3)	RUD (4)	
+	+	+	
-	-	-	
Adjust stunt trim values as needed			

			AIL (AI)	ELEV (EL)
DUAL RATE	POS 0	D/R	90%	90%
		EXP	Adjust as needed	
EXP	POS 1	D/R	100%	100%
		EXP	Adjust as needed	

		L	2	H
THRO CURVE TLN, T2N, THN,	N	0%	50%	100%
TLS, T2S	S	40%	60%	
PITCH CURVE PLN, P2N, PHN,	N	-2° Pitch	5° Pitch	10° Pitch
PLS, P2S, PHS,	S	-10° Pitch	0° Pitch	10° Pitch
PLH, P2H, PHH	H	-5° Pitch	5° Pitch	13° Pitch

CCPM MIXING		ON • OFF
AIL (2)	ELE (3)	Pitch (6)
+ 60%	+ 60%	+ 50%
-	-	-

		CHANNEL MASTER SLAVE	MIX SWITCH	OFFSET	+GAIN	-GAIN
PROG. MIX	A	→	ON • F1 • F0 • H			

TRIM OFFSET	
-------------	--

X-378 HELI DATA SHEET VOYAGER™ 50 STANDARD SETUP

MODEL NO. _____

MODEL NAME Voyager 50 Standard Setup

MODULATION SPCM - ZPCM - PPM _____

			AILE	ELEV	RUDD
DUAL-RATE • EXP	0	D/R	90%	90%	90%
		EXP	20%	20%	30%
	1	D/R	100%	100%	100%
		EXP	30%	30%	30%
A.D.T.	NORM				
	S T - 1				
	S T - 2				
	HOLD				

AUTO D/R (POS. 1)	ST1	OFF • ON
	ST2	OFF • ON
	ST2	OFF • ON

INPUT SEL	AUX2	HOLD SW • PIT.TRIM • INH
	GEAR	ACT • INH

	THRO	AILE	ELEV	RUDD	GEAR	PIT	AUX2
REVERSE SW	<input type="radio"/> NORM <input checked="" type="radio"/> REV	<input type="radio"/> NORM <input checked="" type="radio"/> REV	<input type="radio"/> NORM <input checked="" type="radio"/> REV	<input type="radio"/> NORM <input checked="" type="radio"/> REV	<input type="radio"/> NORM <input checked="" type="radio"/> REV	<input type="radio"/> NORM <input checked="" type="radio"/> REV	<input type="radio"/> NORM <input checked="" type="radio"/> REV
SUB TRIM	ADJUST AS NEEDED						
TRAVEL ADJUST	REFER TO THE CCPM SECTION OF THE MANUAL FOR PROPER SETTINGS						
FAIL SAFE (SPCM)							

	EXP	L	1	2	3	H	
THROTTLE CURVE	N	OFF • ON	0%	%	50%	%	100%
	1	OFF • ON	40%	%	60%	%	100%
	2	OFF • ON	%	%	%	%	%
PITCH CURVE	N	OFF • ON	-2° Pitch	%	5° Pitch	%	10° Pitch
	1	OFF • ON	-5° Pitch	%	5° Pitch	%	10° Pitch
	2	OFF • ON	%	%	%	%	%
	H	OFF • ON	-5° Pitch	%	5° Pitch	%	13° Pitch

GYRO SENS	INH • RUDD D/R • AUTO	0	%
		1	%
		NORM	
		STNT	
		HOLD	
		INVT	

THRO HOLD	<input type="radio"/> OFF <input checked="" type="radio"/> ON	POS Adjust for Idle
--------------	--	------------------------

INVERTED	<input type="radio"/> OFF <input checked="" type="radio"/> ON	OFFSET %
----------	--	-------------

SWASH MIX	TYPE		1S • 2S • <input checked="" type="radio"/> 3S120 • 3S90
	EXP	GAIN	AILE +60%
	<input type="radio"/> OFF • <input checked="" type="radio"/> ON		ELEV +60%
			PITCH -50%

REVO MIX	NORMAL	UP	%
		DOWN	%
	STUNT	UP	%
		DOWN	%
HOLD RUDD OFFSET		%	
ACC MIX			

Refer to your gyro's instructions for proper settings

PROGRAM MIX	CHANNEL	SW	+POS	-POS	OFFSET
	MIX1	→		%	%
	MIX2	→		%	%
	MIX3	→		%	%

X-378 HELI DATA SHEET VOYAGER™ 50 3D SETUP

MODEL NO. _____

MODEL NAME Voyager 50 3D Setup

MODULATION SPCM - ZPCM - PPM _____

			AILE	ELEV	RUDD
DUAL-RATE • EXP	0	D/R	90%	90%	90%
		ADJUST AS NEEDED			
	1	D/R	100%	100%	100%
		ADJUST AS NEEDED			
A.D.T.	NORM		0	0	0
	S T - 1		1	1	1
	S T - 2		1	1	1
	HOLD		1	1	1

AUTO D/R (POS. 1)	ST1	OFF • <input checked="" type="radio"/> ON
	ST2	OFF • <input checked="" type="radio"/> ON
	ST2	OFF • <input checked="" type="radio"/> ON

INPUT SEL	AUX2	HOLD SW • PIT.TRIM • INH
	GEAR	ACT • INH

	THRO	AILE	ELEV	RUDD	GEAR	PIT	AUX2
REVERSE SW	NORM	NORM	<input checked="" type="radio"/> NORM	NORM	<input checked="" type="radio"/> NORM	<input checked="" type="radio"/> NORM	<input checked="" type="radio"/> NORM
	<input checked="" type="radio"/> REV	<input checked="" type="radio"/> REV	<input type="radio"/> REV	<input checked="" type="radio"/> REV	<input type="radio"/> REV	<input type="radio"/> REV	<input type="radio"/> REV
SUB TRIM	ADJUST AS NEEDED						
TRAVEL ADJUST	REFER TO THE CCPM SECTION OF THE MANUAL FOR PROPER SETTINGS						
FAIL SAFE (SPCM)							

	EXP	L	1	2	3	H	
THROTTLE CURVE	N	OFF • <input checked="" type="radio"/> ON	0%	%	50%	%	100%
	1	OFF • <input checked="" type="radio"/> ON	40%	%	60%	%	100%
	2	OFF • <input checked="" type="radio"/> ON	100%	%	60%	%	100%
PITCH CURVE	N	OFF • <input checked="" type="radio"/> ON	-2° Pitch	%	5° Pitch	%	10° Pitch
	1	OFF • <input checked="" type="radio"/> ON	-5° Pitch	%	5° Pitch	%	10° Pitch
	2	OFF • <input checked="" type="radio"/> ON	-10° Pitch	%	0° Pitch	%	10° Pitch
	H	OFF • <input checked="" type="radio"/> ON	-5° Pitch	%	5° Pitch	%	13° Pitch

GYRO SENS	INH • RUDD D/R • <input checked="" type="radio"/> AUTO	0	80%
		1	60%
		NORM	0
		STNT	1
		HOLD	1

THRO HOLD	<input checked="" type="radio"/> OFF	POS
	<input type="radio"/> ON	Adjust for Idle

INVERTED	<input checked="" type="radio"/> OFF	OFFSET
	<input type="radio"/> ON	%

SWASH MIX	TYPE		1S • 2S • <input checked="" type="radio"/> 3S120 • 3S90
	EXP	AILE	+60%
	<input checked="" type="radio"/> OFF	ELEV	+60%
	<input type="radio"/> ON	PITCH	-50%

REVO MIX	NORMAL	UP	%
		DOWN	%
	STUNT	UP	%
		DOWN	%
HOLD RUDD OFFSET		%	
ACC MIX			

Refer to your gyro's instructions for proper settings

PROGRAM MIX		CHANNEL	SW	+POS	-POS	OFFSET
	MIX1	→		%	%	
	MIX2	→		%	%	
	MIX3	→		%	%	

XP8103 HELI DATA SHEET VOYAGER™ 50 STANDARD SETUP

MODEL NO. _____

MODEL NAME Voyager 50 Standard Setup

MODULATION SPCM - ZPCM - PPM _____

			AILE	ELEV	RUDD
DUAL-RATE • EXP	0	D/R	90%	90%	90%
		EXP	Adjust as needed		
	1	D/R	100%	100%	100%
		EXP	Adjust as needed		

AUTO D/R (POS. 1)	ST1	INH • ACT
	ST2	INH • ACT
	ST2	INH • ACT

INPUT SEL	AUX2	HOLD SW • PIT.TRIM • INH
	GEAR	ACT • INH

	THRO	AILE	ELEV	RUDD	GEAR	PIT	AUX2	AUX3
REVERSE SW	NORM • REV	NORM • REV	(NORM) • REV	NORM • REV	(NORM) • REV	(NORM) • REV	(NORM) • REV	(NORM) • REV
SUB TRIM	Adjust as needed							
TRAVEL ADJUST	Refer to the CCPM section of this manual for proper settings							
FAIL SAFE (SPCM)								

	EXP	L	1	2	3	H	
THROTTLE CURVE	N	OFF • ON	0%	30%	50%	70%	100%
	1	OFF • ON	40%	50%	60%	80%	100%
	2	OFF • ON	Optional				
PITCH CURVE	N	OFF • ON	-2° pitch	%	5° pitch	%	10° pitch
	1	OFF • ON	-5° pitch	%	5° pitch	%	10° pitch
	2	OFF • ON	%	%	%	%	%
	H	OFF • ON	-5° pitch	%	5° pitch	%	13° pitch

GYRO SENS	INH • RUDD D/R • AUTO	0	80%
		1	60%
		NORM	0
		STNT	1
		HOLD	1
		INVT	1

Refer to gyro gain section for settings

THRO HOLD	INH • ACT	POS
		Set for idle

THRO HOLD	INH • ACT	OFFSET
		Adjust as needed

REVO MIX	NORMAL	UP	%
		DOWN	%
	STUNT	UP	%
		DOWN	%
ACC MIX			%

Refer to your gyro's instructions for proper settings

		CHANNEL	SW	EXP	L	1	2	3	H
PROGRAM MIX	MIX1	→		OFF-ON					
	MIX2	→		OFF-ON					
				+POS		-POS		OFFSET	
	MIX3	→		%		%			

Swash Type	1 Servo Norm 2 Servo 180° 3 Servo 120° 4 Servo 90°			
	Aile	Elev	Pit	
Exp Act • INH	+ 60%	+ 60%	+ 50%	

XP8103 HELI DATA SHEET VOYAGER™ 50 3D SETUP

MODEL NO. _____

MODEL NAME Voyager 50 3D Setup

MODULATION SPCM - ZPCM - PPM _____

			AILE	ELEV	RUDD
DUAL-RATE • EXP	0	D/R	90%	90%	90%
		EXP	Adjust as needed		
	1	D/R	100%	100%	100%
		EXP	Adjust as needed		

AUTO D/R (POS. 1)	ST1	INH • ACT
	ST2	INH • ACT
	ST2	INH • ACT

INPUT SEL	AUX2	HOLD SW • PIT.TRIM • INH
	GEAR	ACT • INH

	THRO	AILE	ELEV	RUDD	GEAR	PIT	AUX2	AUX3
REVERSE SW	NORM • REV	NORM • REV	NORM • REV	NORM • REV	NORM • REV	NORM • REV	NORM • REV	NORM • REV
SUB TRIM	Adjust as needed							
TRAVEL ADJUST	Refer to the CCPM section of this manual for proper settings							
FAIL SAFE (SPCM)								

		EXP	L	1	2	3	H
THROTTLE CURVE	N	OFF•ON	0%	30%	50%	70%	100%
	1	OFF•ON	100%	80%	50%	80%	100%
	2	OFF•ON	Optional				
PITCH CURVE	N	OFF•ON	-2° pitch	%	5° pitch	%	10° pitch
	1	OFF•ON	10° pitch	%	0° pitch	%	10° pitch
	2	OFF•ON	%	%	%	%	%
	H	OFF•ON	-5° pitch	%	5° pitch	%	13° pitch

GYRO SENS	INH • RUDD D/R • AUTO	0	80%
		1	60%
		NORM	0
		STNT	1
		HOLD	1
		INVT	1

Refer to your gyro's instructions for proper settings

THRO HOLD	INH • ACT	POS Set for idle
THRO HOLD	INH • ACT	OFFSET Adjust as needed

REVO MIX	NORMAL	UP	%
		DOWN	%
	STUNT	UP	%
		DOWN	%
ACC MIX			%

Refer to revolution mixing section for proper settings

		CHANNEL	SW	EXP	L	1	2	3	H
PROGRAM MIX	MIX1	→		OFF-ON					
	MIX2	→		OFF-ON					
				+POS	-POS	OFFSET			
	MIX3	→		%	%				

Swash Type	1 Servo Norm 2 Servo 180° 3 Servo 120° 4 Servo 90°			
	Aile	Elev	Pit	
Exp Act • INH	⊕ 60%	⊕ 60%	⊕ 50%	

10X HELI DATA SHEET

VOYAGER™ 50 3D SETUP

MODEL NO. (84) _____

MODEL NAME (81) Voyager 50 3D Setup _____

MODULATION (85) SPCM-ZPCM-PPM _____

	THRO	AILE	ELEV	RUDD	GEAR	PITCH	AUX2	AUX3	AUX4	AUX5
REVERSE SW	$\begin{matrix} \text{R} \\ \text{N} \end{matrix}$	$\begin{matrix} \text{R} \\ \text{N} \end{matrix}$	$\begin{matrix} \text{R} \\ \text{N} \end{matrix}$	$\begin{matrix} \text{R} \\ \text{N} \end{matrix}$	$\begin{matrix} \text{R} \\ \text{N} \end{matrix}$	$\begin{matrix} \text{R} \\ \text{N} \end{matrix}$	$\begin{matrix} \text{R} \\ \text{N} \end{matrix}$	$\begin{matrix} \text{R} \\ \text{N} \end{matrix}$	$\begin{matrix} \text{R} \\ \text{N} \end{matrix}$	$\begin{matrix} \text{R} \\ \text{N} \end{matrix}$
TRAVEL ADJUST (12)	Refer to the CCPM section of this manual for proper settings									
SUB-TRIM (15)	Adjust as needed									
TRIM RATE (83)	%									

			AILE	ELEV	RUDD
D/R EXP (13)	0	D/R	90%	90%	90%
		EXP	Adjust as needed		
		TYPE			
	1	D/R	100%	100%	100%
		EXP	Adjust as needed		
		TYPE			
2	D/R	Optional			
	EXP				
	TYPE				
AUTO D/R (23)	ST-1	$\text{INH} \cdot \text{ACT}$	$0 \cdot \text{1} \cdot 2$	$0 \cdot \text{1} \cdot 2$	$0 \cdot \text{1} \cdot 2$
	ST-2	$\text{INH} \cdot \text{ACT}$	$0 \cdot 1 \cdot 2$	$0 \cdot 1 \cdot 2$	$0 \cdot 1 \cdot 2$
	ST-3	$\text{INH} \cdot \text{ACT}$	$0 \cdot 1 \cdot 2$	$0 \cdot 1 \cdot 2$	$0 \cdot 1 \cdot 2$
	ST-4	$\text{INH} \cdot \text{ACT}$	$0 \cdot 1 \cdot 2$	$0 \cdot 1 \cdot 2$	$0 \cdot 1 \cdot 2$
	HOLD	$\text{INH} \cdot \text{ACT}$	$0 \cdot \text{1} \cdot 2$	$0 \cdot \text{1} \cdot 2$	$0 \cdot \text{1} \cdot 2$

THROTTLE HOLD (16)	HOLD SW	$\text{INH} \cdot \text{HOLD} \cdot \text{GEAR}$
	POS	Adjust for Idle
	AUTO CUT	$\text{INH} \cdot \text{ACT}$
	Delay	1/4 1/2 3/4 1

FUNCTION SELECT (17)	FLIGHT EXTRA	$\text{INH} \cdot \text{GEAR} \cdot \text{AILE}$	
	GEAR SW	$\text{INH} \cdot \text{GEAR} \cdot \text{HOLD}$	
	AUX2 SW	$\text{INH} \cdot \text{ACT}$	
	PIT. LEVER	LOW	$\text{INH} \cdot \text{ACT}$
		HI	$\text{INH} \cdot \text{ACT}$
	ADT STUNT	$\text{INH} \cdot \text{ACT}$	

GYRO SENS (44)	$\text{INH} \cdot \text{AUX} 3 \cdot \text{AUTO}$	0	Refer to the Gyro Gain Section of this manual for proper settings					
		1						
		2						
		NR	S1	S2	S3	S4	HD	
		0	1				1	

		CHANNEL		TRIM	SW	OFFSET	+GAIN				-GAIN					
		MASTER	SLAVE													
PROGRAM MIX (51) - (58)	1	$\text{INH} \cdot \text{ACT}$	→	OFF ON	NR•S1•S2•S3•S4 HD•AX2•GER											
	2	$\text{INH} \cdot \text{ACT}$	→	OFF ON	NR•S1•S2•S3•S4 HD•AX2•GER											
	3	$\text{INH} \cdot \text{ACT}$	→	OFF ON	NR•S1•S2•S3•S4 HD•AX2•GER											
	4	$\text{INH} \cdot \text{ACT}$	→	OFF ON	NR•S1•S2•S3•S4 HD•AX2•GER											
							EXP	L	1	2	3	4	5	6	H	
	5	$\text{INH} \cdot \text{ACT}$	→	OFF ON	NR•S1•S2•S3•S4 HD•AX2•GER	OFF ON	IN OUT	0								100
	6	$\text{INH} \cdot \text{ACT}$	→	OFF ON	NR•S1•S2•S3•S4 HD•AX2•GER	OFF ON	IN OUT	0								100
	7	$\text{INH} \cdot \text{ACT}$	→	OFF ON	NR•S1•S2•S3•S4 HD•AX2•GER	OFF ON	IN OUT	0								100
8	$\text{INH} \cdot \text{ACT}$	→	OFF ON	NR•S1•S2•S3•S4 HD•AX2•GER	OFF ON	IN OUT	0								100	

10X HELI DATA SHEET

VOYAGER™ 50 INITIAL SETUP CONTINUED

		EXP		L	1	2	3	4	5	6	H	
THRO CURVE (18) TH,TRIM=SLOW HOV.T=CENTER	N	OFF	IN	0							100	
		<input checked="" type="radio"/>	OUT	0			50%				100	
			HOV.SEL	—	HOV	HOV	HOV	HOV	HOV	HOV	HOV	—
	1	OFF	IN	0								100
		<input checked="" type="radio"/>	OUT	100%			60%					100
	2	OFF	IN	0								100
		<input checked="" type="radio"/>	OUT									
	3	OFF	IN	0								100
		<input checked="" type="radio"/>	OUT									
	4	OFF	IN	0								100
		<input checked="" type="radio"/>	OUT									
	PITCH CURVE (68) P,TRIM=CENTER HOV.P=CENTER	N	OFF	IN	0							100
<input checked="" type="radio"/>			OUT	-2°Pitch			5°Pitch				10°Pitch	
			HOV.SEL	—	HOV	HOV	HOV	HOV	HOV	HOV	HOV	—
1		OFF	IN	0								100
		<input checked="" type="radio"/>	OUT	-10°Pitch			0°Pitch					10°Pitch
2		OFF	IN	0								100
		<input checked="" type="radio"/>	OUT									
3		OFF	IN	0								100
		<input checked="" type="radio"/>	OUT									
4		OFF	IN	0								100
		<input checked="" type="radio"/>	OUT									
HOLD		OFF	IN	0								100
	<input checked="" type="radio"/>	OUT	-5°Pitch			5°Pitch					13°Pitch	

TAIL ROTOR CURVE (47)	N	NOR	IN	L	1	2	3	4	5	6	H	
		ORG	OUT									
1	NOR	IN	0	Refer to your gyro's instruction manual for proper settings								100
	ORG	OUT										
2	NOR	IN	0									100
	ORG	OUT										
3	NOR	IN	0									100
	ORG	OUT										
4	NOR	IN	0									100
	ORG	OUT										
MIX RATE		1/1 • 1/2 • 1/4 • 1/10										

TRIM OFFSET (82)	HV.T	HV.P	LO.P	HI.P

Rudder→Throttle 4→1 MIX (41)	R	%
	L	%
MODE SELECTION	NR • <input checked="" type="radio"/> • S2 • S3 • S4 • AX2	

FAIL-SAFE (77)	Z	MODE	HOLD • 1.0s • 0.5s • 0.25s
	S	MEMORY	

Aileron→Throttle 2→1 MIX (41)	R	%
	L	%
MODE SELECTION	NR • <input checked="" type="radio"/> • S2 • S3 • S4 • AX2	

SWASHPLATE MIXING TYPE (65)	1 SERVO ← 3SERVO - 120°CCPM → 3SERVO - 140°CCPM					
	1 SERVO	ELE → AIL	D	%		
U			%			
SWITCH	AIL → ELE	L	%			
		R	%			
3 SERVO 120° CCPM	AIL	+60%	ELE	+60%	PIT	-50%
3 SERVO 140° CCPM	AIL	%	ELE	%	PIT	%

Elevator→Throttle 3→1 MIX (41)	U	%
	D	%
MODE SELECTION	NR • <input checked="" type="radio"/> • S2 • S3 • S4 • AX2	

The Voyager™ 50 has been designed to be flown by experienced R/C heli pilots. Radio controlled models such as this may crash and cause both property damage and/or bodily harm to both the operator and/or spectators if not properly assembled and operated. When operating your Voyager 50, please exercise high levels of caution and safety. If you are a beginner, please seek help from an experienced RC heli pilot.

After Assembly

- Check to ensure that all bolts have been secured.
- Be sure to use thread-lock where instructed.
- Check to ensure that the main rotor and the tail rotor are secured with bolts.
- Check to ensure that the blades move slightly with gentle finger pressure.
- Turn the fully charged radio system on, switching on the transmitter first, then the receiver. (Hereafter keep this order when turning on the switches.)
- Move the sticks (throttle, pitch, aileron, elevator, then the rudder) to ensure that each function operates properly at the helicopter.
- Do not cut or bundle the receiver antenna wire. Also, make sure to pass the antenna wire through the antenna tube to prevent it from making contact with the rotor or the gears.

Before Flight

- After filling the tank with fuel, check to make sure that no fuel leakage is detected.
- Check to ensure the main rotor and the tail rotor are free from cracks and breaks. Do not fly with them when any such defects are detected.
- Check to ensure the correct control movements when the transmitter is switched on, making sure that the throttle stick is returned to its lowest position before starting the engine. It is extremely important that the carburetor is closed when the throttle stick and trim is in the low position. If not, adjust the linkage.
- Use caution so that the transmitter's sticks are not caught in your clothing.
- Make sure to check the battery to confirm it has enough duration to complete the flight.
- Range check the transmitter at a distance of more than 60–75 feet from the model with the transmitter antenna down. Make sure that the control functions at the model correspond with the stick movements. If not, find the cause and fix it.
- Make sure that the rotation of the starter has completely stopped before removing the JR hex Starting Shaft.
- To avoid interference, make sure that no one is using the same frequency at the same time. If you experience interference when no one is using the same brand the cause could be from an external source. **Do not fly** until the frequency is clear.
- Needle adjustments to the engine should be made while holding the main rotor head. Throttle hold can be switched in, using a setting equal to engine idle, to make sure that the engine does not respond to accidental movements of the throttle stick.
- When starting the engine, check to ensure that the throttle stick is in the proper idle position. If the throttle stick is in the high position, the engine will rotate the main rotor rapidly and this is very dangerous. When starting the motor, hold the main rotor head securely with your hand.

During Flight

- Do not fly your Voyager 50 near any houses, high voltage wires and busy roads.
- Be sure to fly within the reach of your radio's range. Collision or contact with an out of control model could cause injury.
- Keep your eyes on your model while flying. The helicopter can change attitude or get out of sight in a short time and it may soon be out of control.
- It is dangerous to fly (while hovering etc.) with the rotor at your eye level. Be sure that the rotor is higher than your eye level.
- Check to ensure that your model has enough fuel at all times.
- When the rotor speed has decayed to very low revolutions, use the palm of your hand on the head button to bring it to a stop. Do not touch the main rotor blades or flybar paddles.
- If you feel that something is wrong with your model while flying, land it immediately and find the fault before flying again.

After the Flight

- Check to ensure there are no loose bolts or joints.
- If the main rotor or other parts have made contact with the ground during flight, make sure to replace the parts before the next flight even if they look to be in good condition.
- Make sure to install the battery, receiver, and gyro securely so that they don't break loose in flight.
- The receiver antenna wire needs a periodical check up to make sure that it is not broken inside its outer plastic cover.

ADVICE AND BASIC HOVER TRAINING PRACTICES

Flight Training

Flight Simulators

A model helicopter simulator is *highly recommended* and is an excellent training aid. Simulators like the CSM V10 will help you learn the orientation and inputs needed to fly a model helicopter, without the risk of damaging your model to learn these same reactions. In general, most beginning pilots find that using an RC simulator prior to their first actual flights with their model increase the speed in which they learn, and also decrease the number of crashes associated with learning to fly. Even the most experienced heli pilots continue to practice with a flight simulator to learn new maneuvers and stick inputs prior to trying these maneuvers with their actual models.

Training Gear

Before you commence, it is *highly recommended* that you first purchase and install helicopter flight training gear to your Voyager™ 50 to prevent accidental prior to tracking the blades or attempting to fly the model.

Experienced Help

Seek help from an experienced RC helicopter pilot prior to your first flights. Contact your local hobby shop for more information on clubs and pilots in your area.

Where to Fly

For your first flights, locate a large smooth parking lot or paved surface that is in a private setting. The training gear will allow the model to slide smoothly on a flat hard surface, which will reduce the risk of tipovers while learning. A smooth grass surface will also work if it is not possible to locate a large parking lot, however the training gear will have a tendency to catch in the grass which increases the possibility of a tip over.

When to Fly

Chose a day with calm or no wind as the model will be much easier to control without the additional wind factor. Generally, you will want to pick a day where the wind is below 5 mph if possible for the best results. Please also note that the model should always be positioned nose into the wind for the best results.

Basic Hover Training Practices

Once you have properly tracked the main rotor blades and have tuned the engine as needed, it is now time to move on to the initial flight training practices listed below.

Ground Skating

The first step towards learning to fly is ground skating. The model should be positioned nose into the wind, and the pilots should be located approximately 15–20 feet behind the model, and slightly to the left or right. The tail of the model should always face towards the pilot during these initial flight practices. To start ground skating, simply increase the throttle slowly until the model starts to become light in the training skids. Next, move the cyclic stick forward slightly; the model should slide forward. Begin to skate the model slowly to the left, right, forward and backwards gently until you become familiar with the stick inputs. Once you have become comfortable with this, you can also practice rotating the model to the left and right using the rudder stick. Be careful when doing this; if the model rotates the nose towards you, the cyclic controls will be reversed.

ADVICE AND BASIC HOVER TRAINING PRACTICES (CONTINUED)

Short Stationary Hovering

Once you have become comfortable with grounds skating, your next step is to try to perform a short stationary hover. To do this, increase the throttle slowly until the model starts to lift from the ground. When the model is 1 foot from the ground, gently reduce the throttle so that the model will settle back down gently. Continue this procedure, and try to increase the time that the model remains airborne. It is important that you keep the model within 3 feet of the ground while performing this exercise, as this will prevent an accidental tip over.

Long Stationary Hovering

Once you have become comfortable with the short stationary hover, the next step is to try to increase the length of time that you are able to keep the model in stationary hover. Continue to practice this exercise until you are able to keep the model in a stationary hover for a full tank of fuel.

Traveling Hover

Once you have become comfortable with the long stationary hover, the next step is to try to perform a traveling hover. To do this, lift the model into a stationary hover approximately 1 foot from the ground. Next, move the cyclic stick forward gently, the model will start moving forward. Once the model has traveled 10–15 feet, gently pull back on the cyclic stick until the model returns to stationary hover. Next, gently move the cyclic stick backwards until the model returns to its original position in stationary hover. Repeat this exercise for left and right cyclic as well.

Once you have completed these exercises, you are well on your way to learning to Hover. Please seek advice from an experienced heli pilot in your area on flight progression from this stage forward.

GENERAL MAINTENANCE

Engine

After each day of flying, fully drain the fuel tank. Then, start the engine and let it idle until the engine and the fuel line are completely burned off. It is also suggested that an after-run oil be used to prevent premature engine corrosion.

Tail Rotor Belt

Periodically check the tension on the tail drive belt (as shown in Step 5-8, page 26) to insure that it has sufficient tension for proper engagement. It is especially important to check this after initial test flights.

Check All Nuts and Bolts

A helicopter is subject to high vibration during flight. It is important to check that all screws, nuts, and bolts are properly secured after each day of flying. It is also suggested that you perform a “quick” inspection between each initial test flight for approximately the first 6–10 flights.

Check Ball Link Wear

Check to insure that all universal links fit freely but securely to the control balls. If there is excessive play noted, replace the universal link in question.

Battery Maintenance

Check to insure that your batteries are properly mounted and charged. The most frequent cause of crashes (aside from pilot error) is battery failure or disconnection. Be certain that your batteries are fully charged and limit your flight time to 3 or 4 flights between charging. If more flight time is required, purchase a reliable quick field charger.

Cleaning

At the end of each flight or flying session, wipe down your helicopter with a clean towel or rag. This is also a good time to inspect all parts for tightness or fatigue. A clean, well-maintained helicopter will provide you with many hours of trouble-free flight.

PREASSEMBLED COMPONENTS

The following parts included in this kit are preassembled. When repair or maintenance is necessary, refer to the diagram below for disassembly or re-assembly.

SEESAW ARM ASSEMBLY

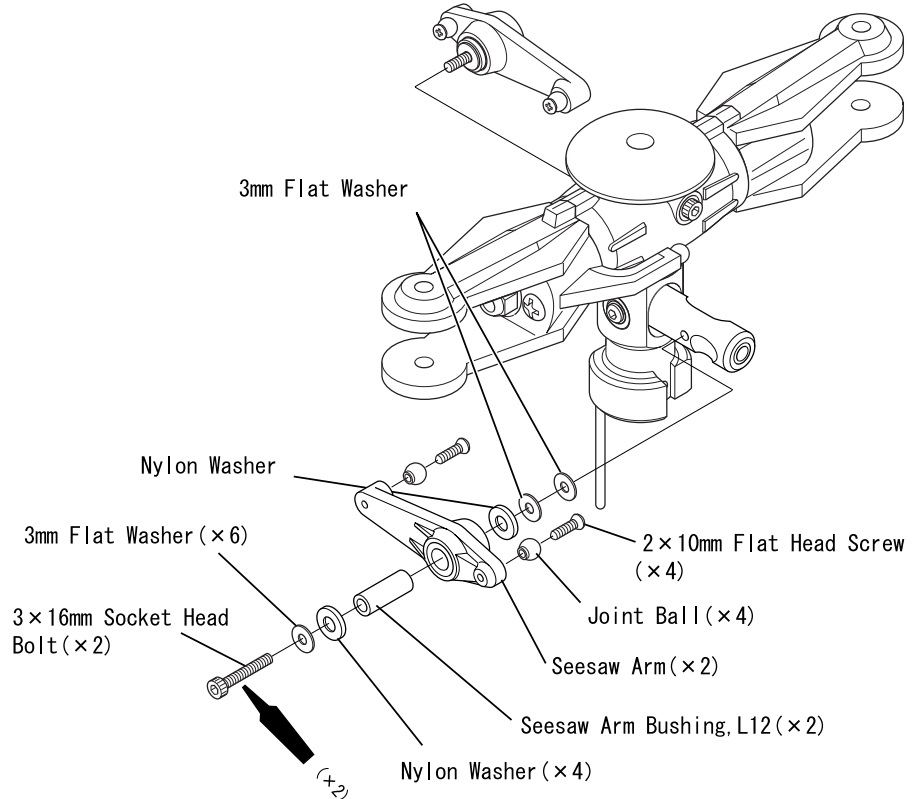
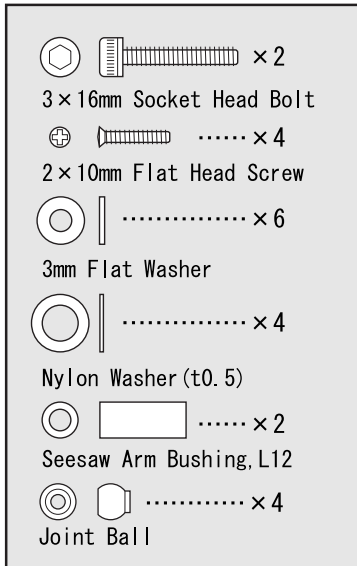

SEESAW ASSEMBLY

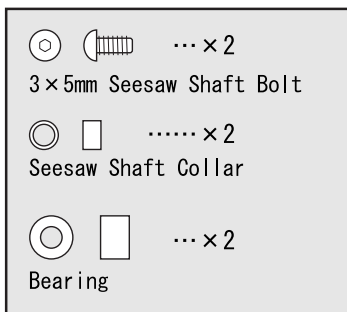

It will be necessary to remove one of the seesaw arms to remove the seesaw shaft.

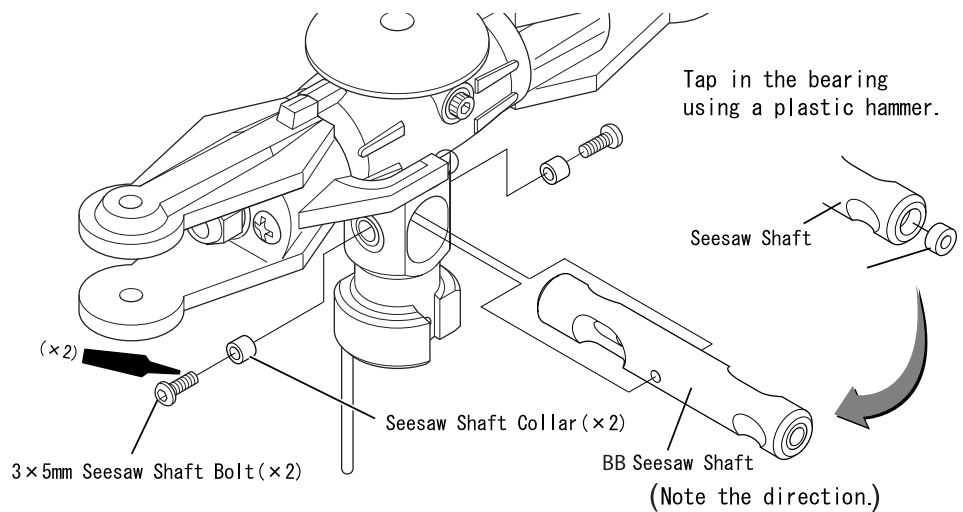

MAIN BLADE HOLDERS ASSEMBLY

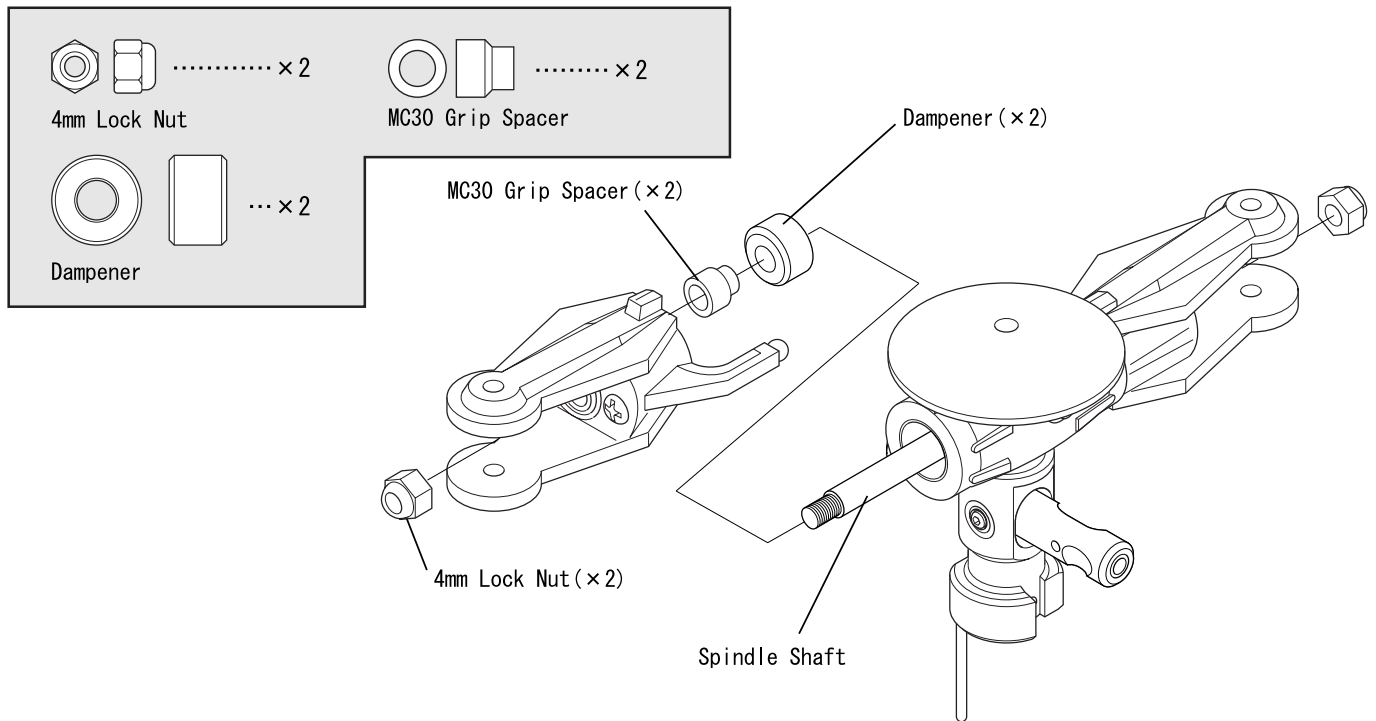

CENTER HUB ASSEMBLY

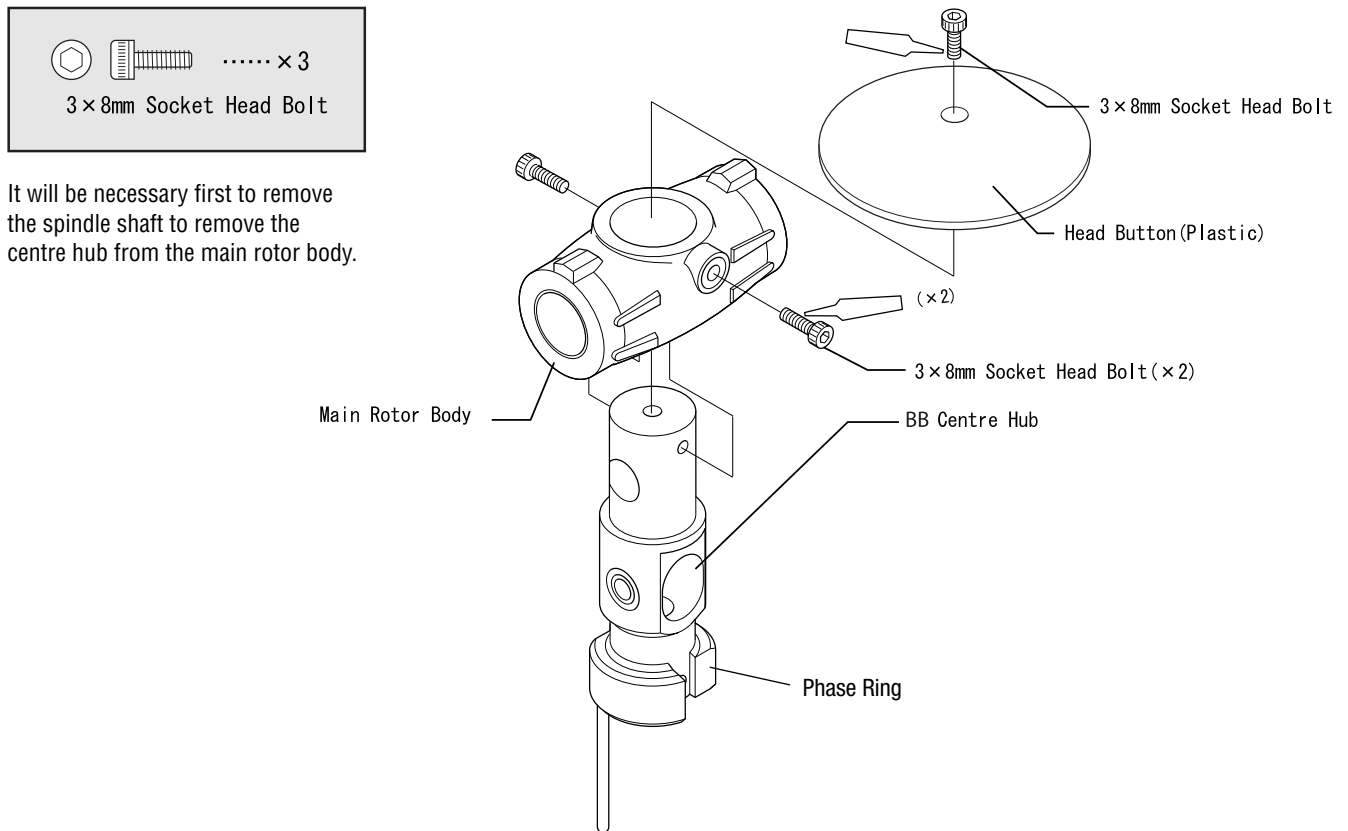

It will be necessary first to remove the spindle shaft to remove the centre hub from the main rotor body.



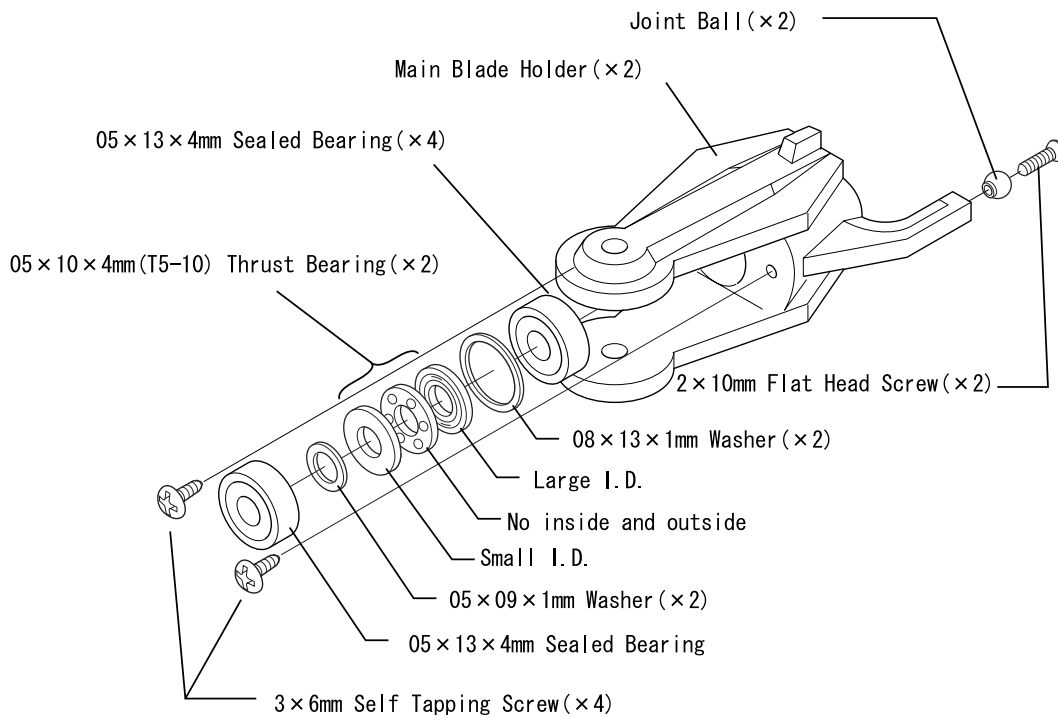
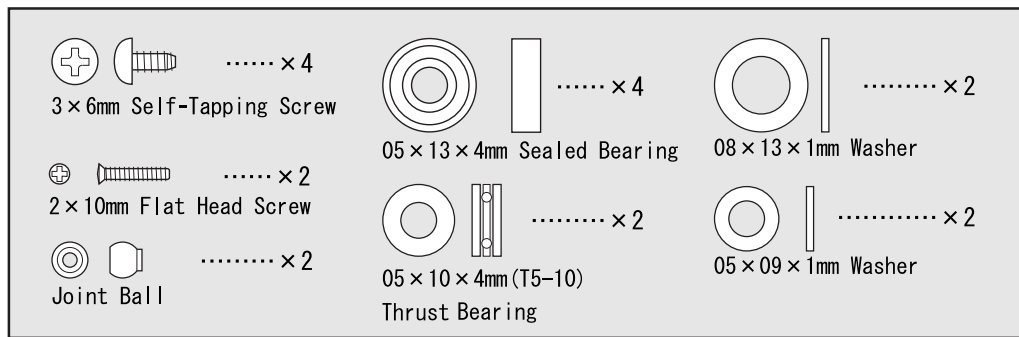



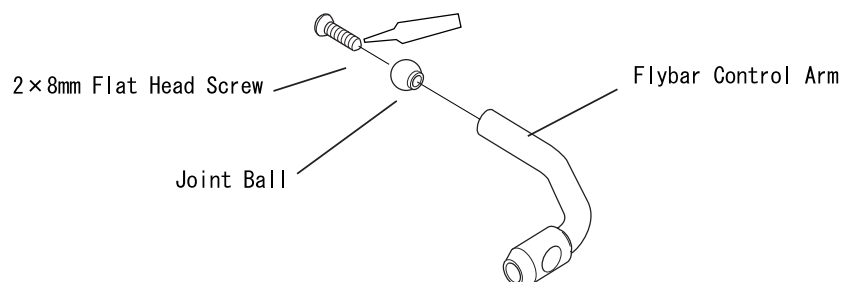
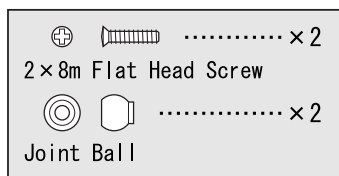

MAIN BLADE HOLDERS ASSEMBLY



FLYBAR CONTROL ARM





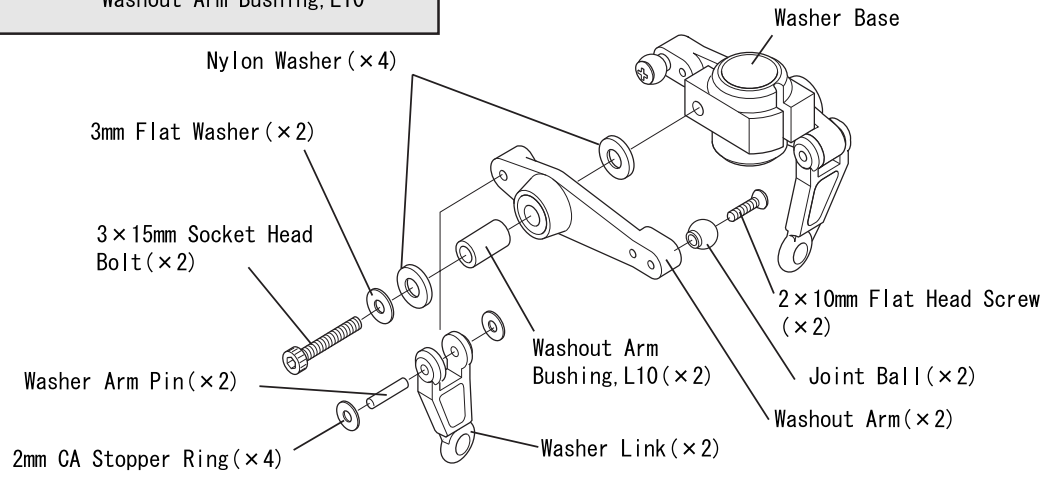

WASHOUT ASSEMBLY

  × 2	 × 2	 × 2
 × 2	 × 4	 × 4
 × 2	 × 2	



SWASHPLATE ASSEMBLY

 × 4	 × 3
 × 4	
 × 3	

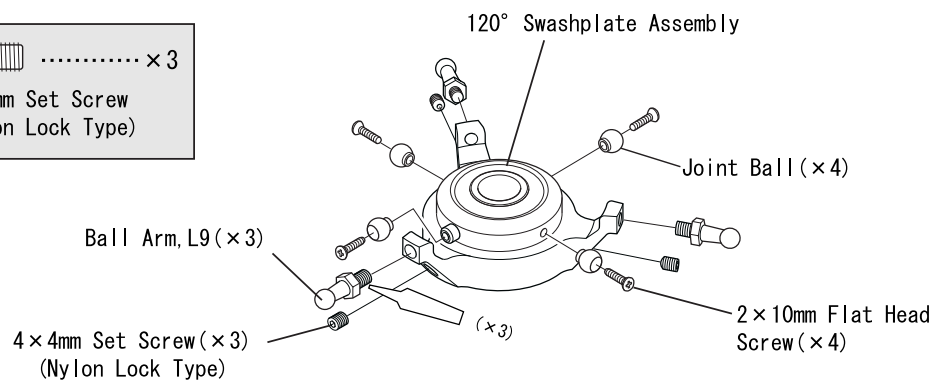

TAIL PITCH PLATE ASSEMBLY

 × 2

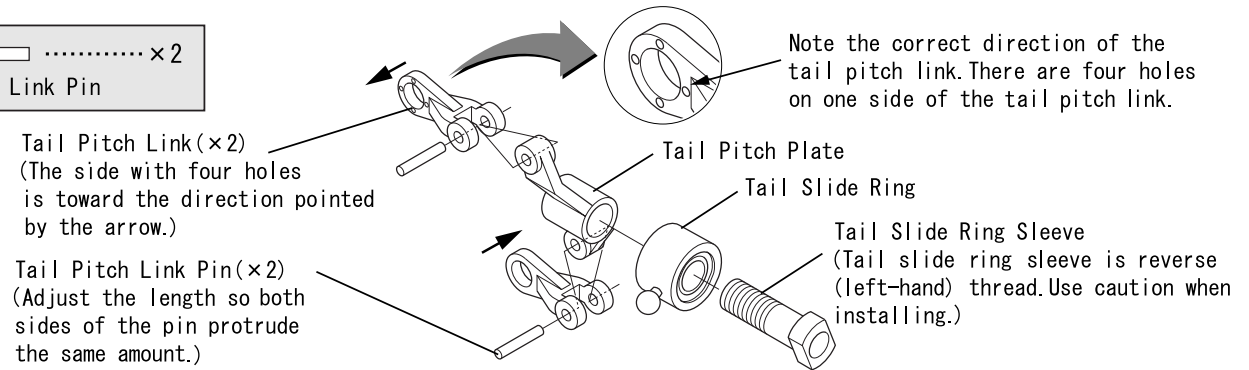

MAIN ROTOR HEAD ASSEMBLY

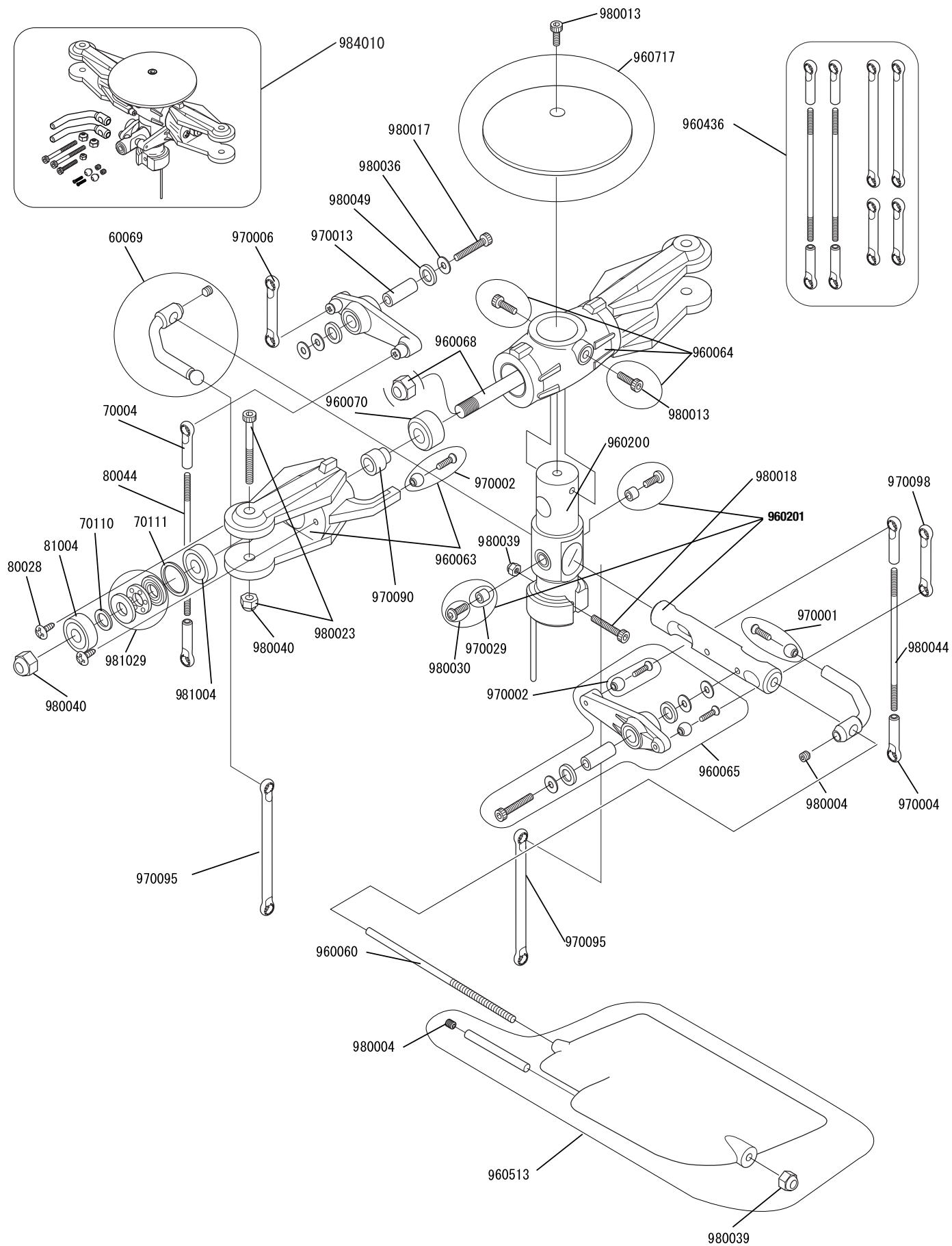

CONTROL SYSTEM / SWASHPLATE / WASHOUT UNIT ASSEMBLY

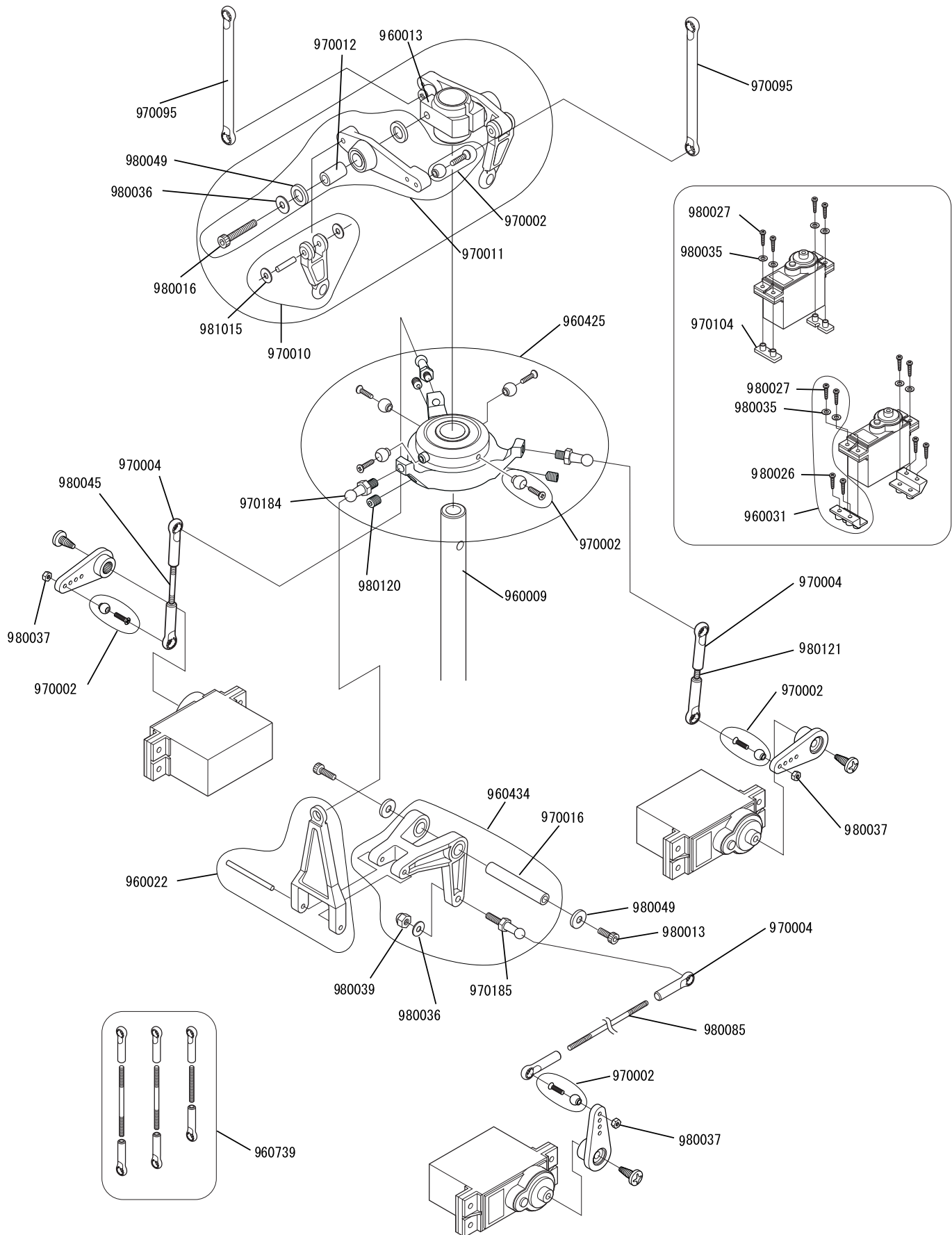

ENGINE / CLUTCH / CLUTCH BELL ASSEMBLY

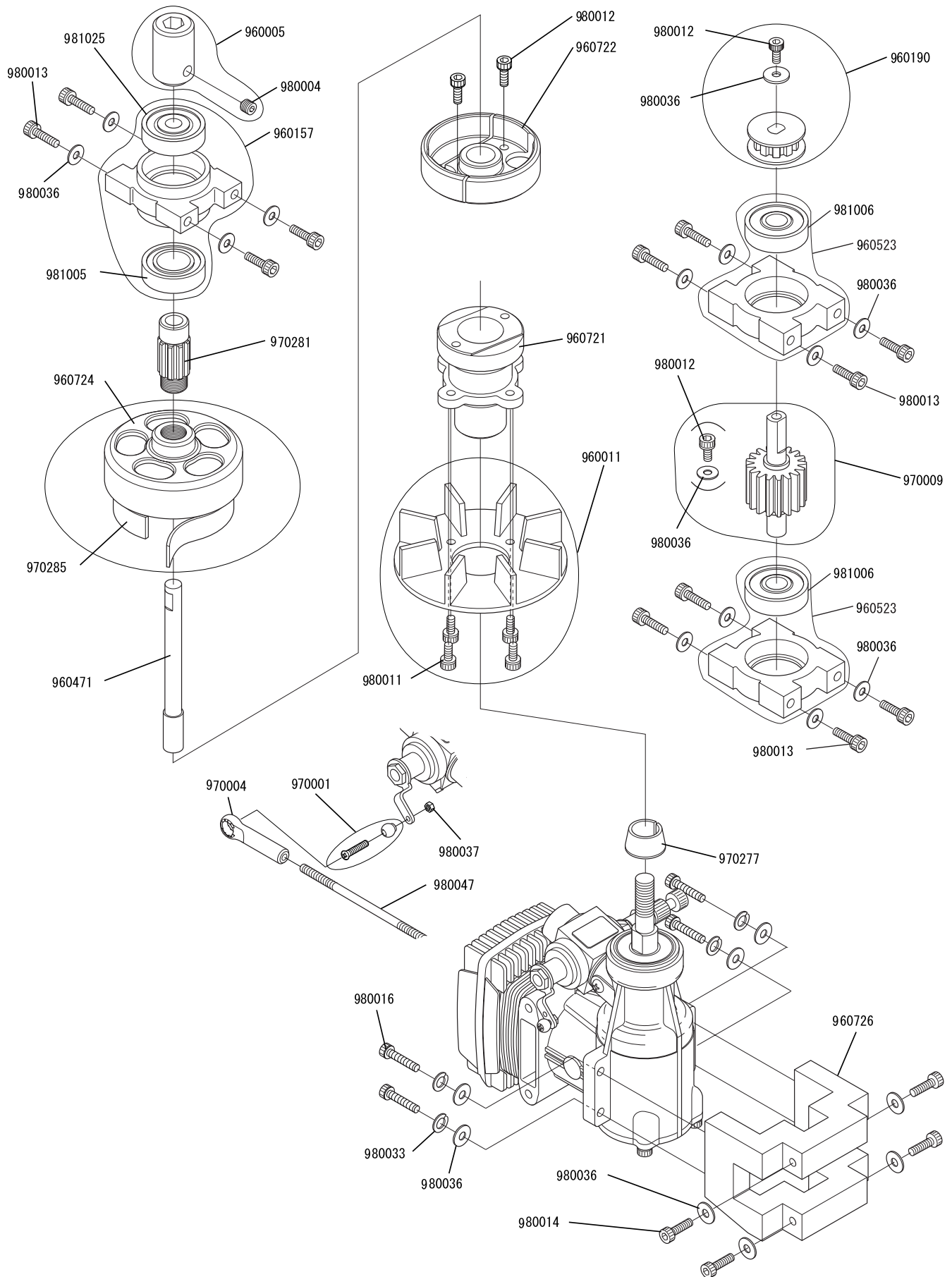

MAIN FRAME CLUTCH / DRIVE GEAR ASSEMBLY

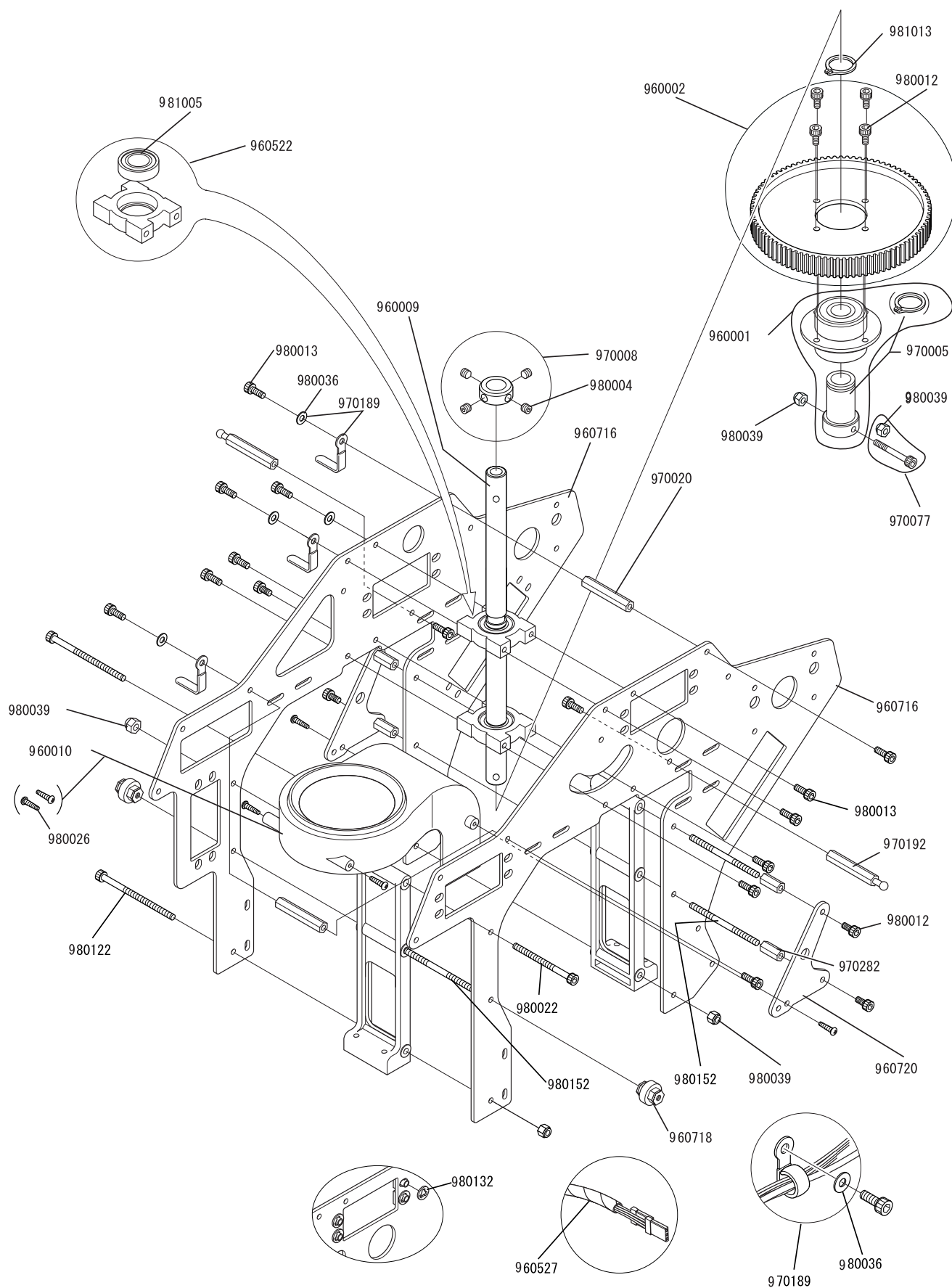

FUEL TANK / LANDING GEAR ASSEMBLY

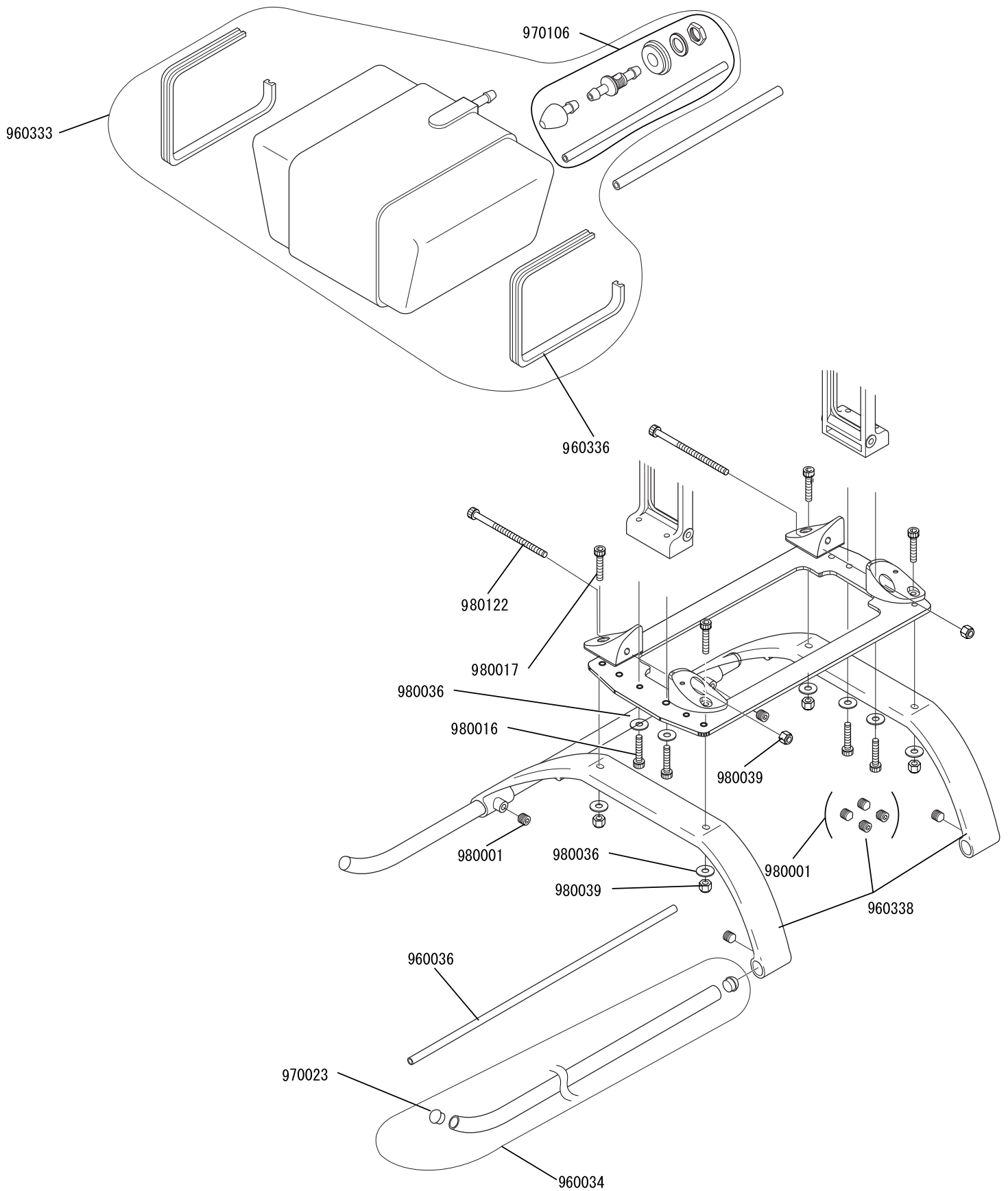

FUEL TANK FRAME / RADIO BED / TAIL BOOM ASSEMBLY

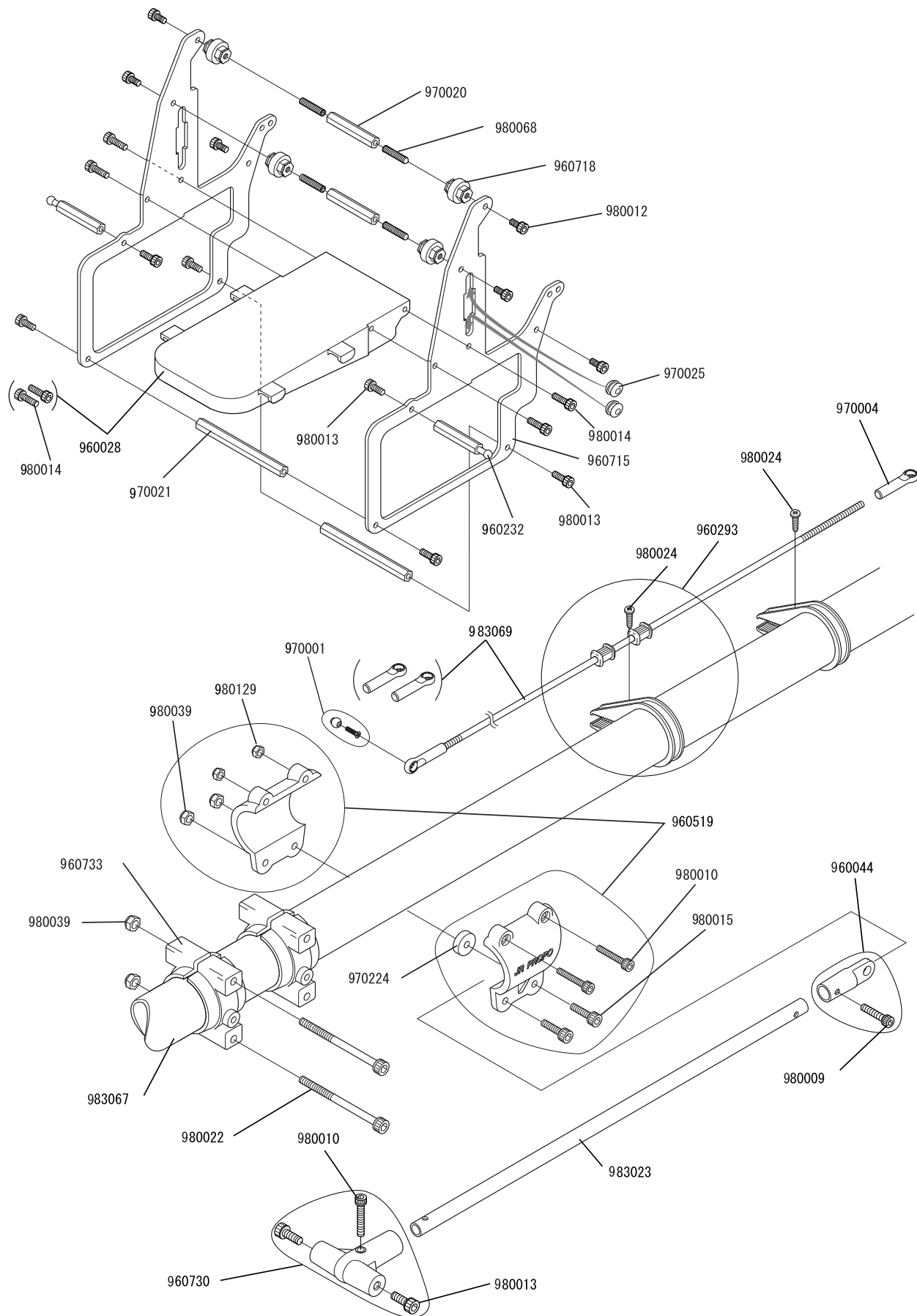

TAIL ROTOR ASSEMBLY

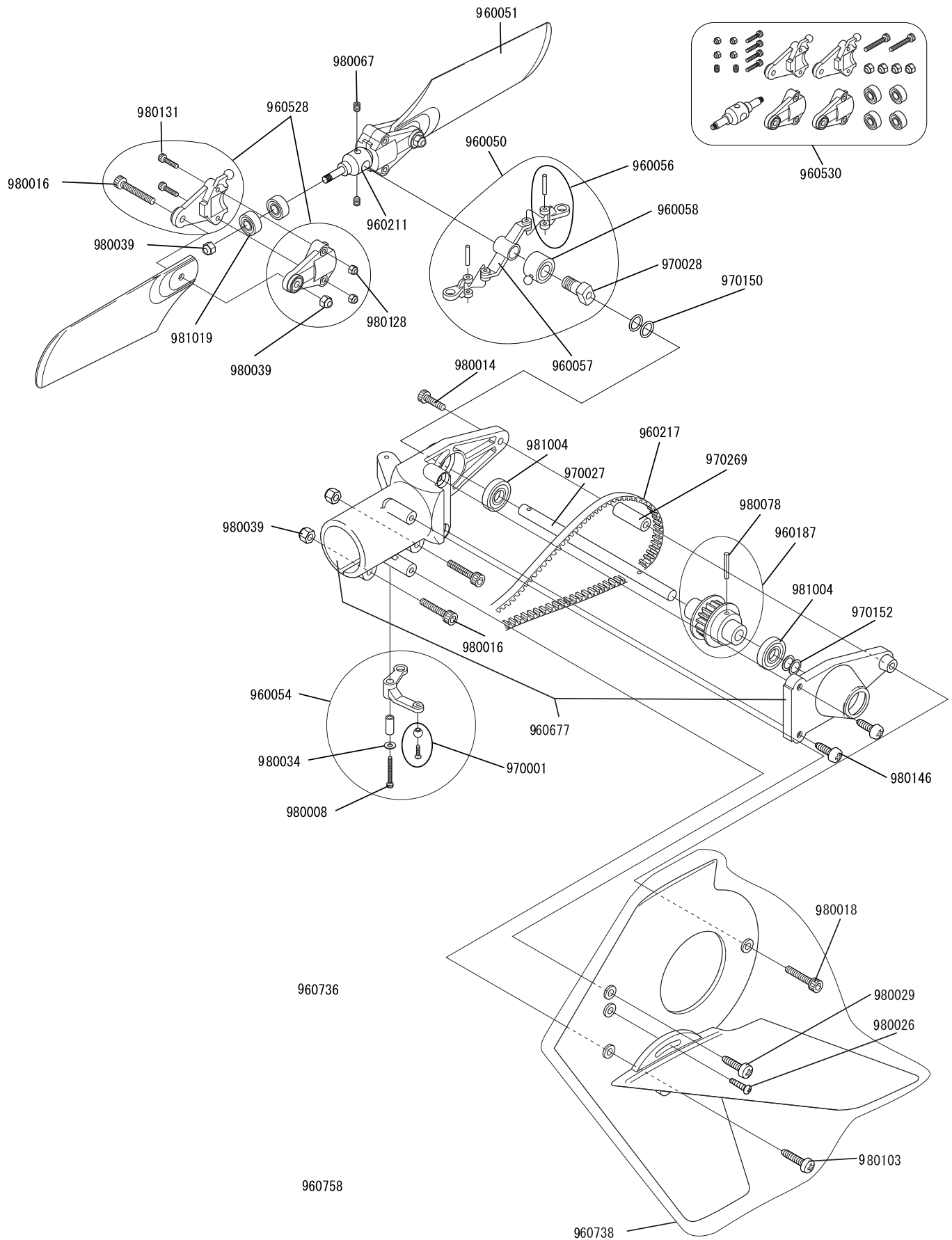

PARTS LISTINGS

Part No	Description	Quantity	Comments
960001	Autorotation Assembly		w/Autorotation Shaft
	Autorotation Assembly	×1	
960002	Drive Gear T88		
	Drive Gear T88	×1	
	3×6mm Socket Head Bolt	×4	
960005	Starter Hex Adapter		
	Starter Hex Adapter	×1	
	4×4mm Set Screw	×1	
960009	Main Rotor Shaft		
	Main Rotor Shaft	×1	
960010	Cooling Fan Shroud		
	Cooling Fan Shroud	×1	
	2.6×8mm Self-Tapping Screw	×4	
960011	Cooling Fan		
	Cooling Fan	×1	
	3×5mm Socket Head Bolt	×4	
960013	Washout Base		
	Washout Base	×1	
960022	Swashplate A Arm		
	Swashplate A Arm	×2	
	Elevator Arm Pin	×2	
960028	Front Radio Bed		
	Front Radio Bed	×1	
	3×10mm Socket Head Bolt	×2	
960031	Servo Mounting Plate		
	Servo Mounting Plate	×4	
	2.6×8mm Self-Tapping Screw	×8	
	2.6×12mm Self-Tapping Screw	×8	
	2.6mm Flat Washer	×8	
960034	Landing Skid		
	Landing Skid	×2	
	Landing Skid Cap	×4	
960036	Antenna Tube		
	Antenna Tube	×3	
960040	2.5×5 Silicone Fuel Tubing(1m)		
	2.5×5 Silicone Fuel Tubing(1m)	×1	
960044	Tail Brace Connector		
	Tail Brace Connector	×1	
	2.6×12mm Socket Head Bolt	×1	
960050	Tail Slide Ring Assembly		
	Tail Slide Ring Assembly	×1	
960051	Tail Rotor Blade		
	Tail Rotor Blade	×2	
960054	Tail Pitch Control Lever		
	Tail Pitch Control Lever	×1	
	Tail Lever Bushing	×1	
	2×20mm Socket Head Bolt	×1	
	2mm Flat Washer	×1	
	Joint Ball	×1	
2×8mm Flat Head Screw	×1		
960056	Tail Pitch Link		
	Tail Pitch Link	×2	
	Tail Pitch Link Pin	×2	
	2mm CA Stopper Ring	×4	
960057	Tail Pitch Plate		
	Tail Pitch Plate	×1	
960058	Tail Slide Ring		Bearing Installed
	Tail Slide Ring	×1	
960060	Flybar L540		
	Flybar L540	×2	

PARTS LISTINGS

Part No	Description	Quantity	Comments
960063	Main Blade Holder		
	Main Blade Holder	×2	
	2×10mm Flat Head Screw	×2	
	Joint Ball	×2	
960064	Main Rotor Body		
	Main Rotor Body	×1	
	3×8mm Socket Head Bolt	×2	
960065	Seesaw Arm		
	Seesaw Arm	×2	
	Arm Shaft L12	×2	
	Nylon Washer (t0.5)	×4	
	2×10mm Flat Head Screw	×4	
	Joint Ball	×4	
	3×16mm Socket Head Bolt	×2	
3mm Flat Washer	×6		
960068	Blade Spindle Shaft		
	Blade Spindle Shaft	×1	
	4mm Lock Nut	×2	
960069	Flybar Control Arm		
	Flybar Control Arm	×2	
	4×4mm Set Screw	×2	
	2×8mm Flat Head Screw	×2	
	Joint Ball	×2	
960070	Blade Damper Rubber 50°		
	Blade Damper Rubber 50°	×4	
960072	Rubber Grommet		
	Rubber Grommet	×4	
960157	Start Shaft Bearing Blocks Assembly		w/two bearings
	Start Shaft Bearing Blocks Assembly	×1	
960187	Tail Drive Pulley		
	Tail Drive Pulley	×1	
	2×13mm Spring Pin	×1	
960190	Front Tail Pulley		
	Front Tail Pulley	×1	
	3×6mm Socket Head Bolt	×1	
	3mm Flat Washer	×1	
960200	High Cycle Center Hub	×1	w/phase ring & links
960201	BB Seesaw Shaft	×1	w/screws
960211	HG Tail Centre Hub		
	HG Tail Centre Hub	×1	
960217	Tail Drive Belt (S3M1596)		
	Tail Drive Belt (S3M1596)	×1	
960232	Body Mounting Standoff L21		
	Body Mounting Standoff L21	×2	
960293	Tail Rod Guide B Set		
	Tail Control Rod Guide B	×4	
	Rod Guide	×1	
	Tail Control Rod Bushes B	×4	
	Tail Control Rod Bushes	×1	
	3×10mm Socket Head Bolt	×1	
2×8mm Self Tapping Screw	×4		

PARTS LISTINGS

Part No	Description	Quantity	Comments
960333	Fuel Tank Set		
	Fuel Tank	× 1	
	Tank Nipple B	× 1	
	Tank Grommet B	× 1	
	Tank Mounting L230	× 2	
	Fuel Tank Clunk	× 1	
	2.5×5mm Silicone Fuel Tubing	× 1	
	7×12×1 Washer	× 1	
	7mm Nut	× 1	
960336	Tank Mounting		
	Tank Mounting(1m)	× 1	
960338	Low Profile Landing Struts(White)		
	Low Profile Landing Struts	× 2	
	3×4mm Set Screw	× 2	
960425	Swashplate Assembly		
	Swashplate Assembly	× 1	
	4×4mm Set Screw(Nylon Lock Type)	× 3	
960434	Elevator Arm F-B		
	Elevator Arm F-B	× 1	
	Arm Shaft L32	× 1	
	Ball Arm L11	× 1	
	3mm Lock Nut	× 1	
	3mm Flat Washer	× 1	
960436	Linkage Set G		
	2.3×40mm Control Rod	× 2	
	Double Link A	× 2	
	Double Link L	× 2	
	Universal Link	× 4	
960471	Start Shaft		
	Start Shaft	× 1	
960513	Flybar Paddle C		
	Flybar Paddle C	× 2	
	Inset Weight	× 2	
	3mm Lock Nut(t2.8)	× 2	
	4×4mm Set Screw	× 2	
960519	Tail Brace Clamp B L/R		
	Tail Brace Clamp B L/R	× 1 each	
	3×7×3mm Plastic Spacer	× 2	
	3×12mm Socket Head Bolt	× 2	
	2.6×15mm Socket Head Bolt	× 2	
	3mm Lock Nut(t2.8)	× 2	
	2.6mm Lock Nut	× 2	
960522	Bearing Case C Assembly(L-1910ZZ)		w/Bearing(L-1910ZZ)
	Bearing Case C Assembly(L-1910ZZ)	× 1	
960523	Bearing Case D Assembly(R-1960ZZ)		w/Bearing(R-1960ZZ)
	Bearing Case D Assembly(R-1960ZZ)	× 1	
960527	Spiral Tube(1m)		
	Spiral Tube(1m)	× 1	
960528	Tail Blade Holder Set		
	Tail Blade Holder	× 2	
	Tail Blade Holder(w/Ball)	× 2	
	2×10mm Socket Head Bolt	× 4	
	3×15mm Socket Head Bolt	× 2	
	2mm Lock Nut	× 4	
	3mm Lock Nut(t2.8)	× 2	

PARTS LISTINGS

Part No	Description	Quantity	Comments
960530	HG Tail Centre Hub Set		
	HG Tail Centre Hub	×1	
	Tail Blade Holder	×2	
	Tail Blade Holder (w/Balls)	×2	
	2×10mm Socket Head Bolt	×4	
	3×15mm Socket Head Bolt	×2	
	2mm Lock Nut	×4	
	3mm Lock Nut (t2.8)	×4	
	3×3mm Set Screw	×2	
	4×10×4mm Shielded Bearing	×4	
960677	Tail Gear Case B L/R		
	Tail Gear Case B L/R	×1 each	
960715	Tank Frame		
	Tank Frame	×2	
960716	Main Frame R/L		
	Main Frame R	×1	
	Main Frame L	×1	
960717	Head Button (Plastic)		
	Head Button	×1	
	3×8mm Socket Head Bolt	×1	
960718	Floating Dampener		
	Floating Dampener	×2	
960720	Fan Cover Stay		
	Fan Cover Stay	×2	
960721	Cooling Fan Hub		
	Cooling Fan Hub	×1	
960722	Clutch Assembly		Bearing Installed
	Clutch Assembly	×1	
	3×6mm Socket Head Bolt	×2	
960724	Clutch Bell Assembly		05×10×4 Bearing Installed
	Clutch Bell Assembly	×1	
960725 960725 B	Carbon Frame Plate		
	Carbon Frame	×1	
	Landing Gear Blocks	×4	
960726	.50 Engine Mount		OS 45FX-H, OS 50SX-H
	.50 Engine Mount : OS/Webra	×1	
960730	Tail Brace T End		
	Tail Brace T End	×1	
	2.6×15mm Socket Head Bolt	×1	
	3×8mm Socket Head Bolt	×2	
960732	Main Frame Standoff B		
	Main Frame Standoff B	×1	
960733	Tail Boom Holder		
	Tail Boom Holder	×2	
960736	Decal A		
	Decal	×1	
960758	Assembly Instruction		
	Assembly Instruction	×1	
960738	T-Type Fin Set (White)		
	Horizontal Fin	×1	
	Vertical Fin	×1	
	2.6×8mm Self-Tapping Screw	×1	
	3×12mm Self-Tapping Screw	×2	
	3×14mm Self-Tapping Screw	×1	
	3×18mm Socket Head Bolt	×1	
960739	Linkage Set M		
	2.3×25mm Control Rod	×1	
	2.3×45mm Control Rod	×1	
	2.3×55mm Control Rod	×1	
	Universal Link	×6	

PARTS LISTINGS

PARTS LISTINGS

Part No	Description	Quantity	Comments
970104	Servo Mounting Plate B		
	Servo Mounting Plate B	×10	
970106	Tank Cap Set		
	Tank Nipple B	×1	
	Tank Grommet B	×1	
	Fuel Tank Clunk	×1	
	2.5×3.6×150mm Silicone Fuel Tubing	×1	
	7×12×1mm Washer	×1	
	7mm Nut	×1	
970110	5×9×1mm Washer		
	5×9×1mm Washer	×2	
970111	8×13×1mm Washer		
	8×13×1mm Washer	×2	
970150	5×7×1mm O-Ring		
	5×7×1mm O-Ring	×2	
970152	5×7×0.05mm Washer		
	5×7×0.05mm Washer	×2	
970184	Ball Arm L9		
	Ball Arm L9	×1	
970185	Ball Arm L11		
	Ball Arm L11	×1	
970189	Cord Holder		
	Cord Holder	×10	
	3mm Flat Washer	×10	
970192	Body Mounting Standoff L37		
	Body Mounting Standoff L37	×2	
970193	Seesaw Limiter		
	Seesaw Limiter	×2	
970204	Canopy Mounting Standoff L32		
	Canopy Mounting Standoff L32	×2	
970224	3×7×3mm Plastic Spacer		
	3×7×3mm Plastic Spacer	×2	
970269	Tail Gear Case Standoff L17		
	Tail Gear Case Standoff L17	×1	
970277	Taper Collet		
	Taper Collet	×1	
970281	Pinion Gear T9B		
	Pinion Gear T9B	×1	
970282	Main Frame Standoff L12		
	Main Frame Standoff L12	×2	
970285	Clutch Lining		
	Clutch Lining	×1	
980001	3×4mm Set Screw		
	3×4mm Set Screw	×10	
980004	4×4mm Set Screw		
	4×4mm Set Screw	×10	
980006	2×8mm Socket Head Bolt		
	2×8mm Socket Head Bolt	×10	
980008	2×20mm Socket Head Bolt		
	2×20mm Socket Head Bolt	×10	
980009	2.6×12mm Socket Head Bolt		
	2.6×12mm Socket Head Bolt	×10	
980010	2.6×15mm Socket Head Bolt		
	2.6×15mm Socket Head Bolt	×10	
980011	3×5mm Socket Head Bolt		
	3×5mm Socket Head Bolt	×10	
980012	3×6mm Socket Head Bolt		
	3×6mm Socket Head Bolt	×10	
980013	3×8mm Socket Head Bolt		
	3×8mm Socket Head Bolt	×10	
980014	3×10mm Socket Head Bolt		
	3×10mm Socket Head Bolt	×10	

PARTS LISTINGS

Part No	Description	Quantity	Comments
980015	3 × 12mm Socket Head Bolt		
	3 × 12mm Socket Head Bolt	× 10	
980016	3 × 15mm Socket Head Bolt		
	3 × 15mm Socket Head Bolt	× 10	
980017	3 × 16mm Socket Head Bolt		
	3 × 16mm Socket Head Bolt	× 10	
980018	3 × 18mm Socket Head Bolt		
	3 × 18mm Socket Head Bolt	× 10	
980022	3 × 40mm Socket Head Bolt		
	3 × 40mm Socket Head Bolt	× 10	
980023	4 × 30mm Main Blade Bolt		
	4 × 30mm Main Blade Bolt	× 2	
	4mm Nylon Nut	× 2	
980024	2 × 8mm Self-Tapping Screw		
	2 × 8mm Self-Tapping Screw	× 10	
980025	2.3 × 8mm Self-Tapping Screw		
	2.3 × 8mm Self-Tapping Screw	× 10	
980026	2.6 × 8mm Self-Tapping Screw		
	2.6 × 8mm Self-Tapping Screw	× 10	
980027	2.6 × 12mm Self-Tapping Screw		
	2.6 × 12mm Self-Tapping Screw	× 10	
980028	3 × 6mm Self-Tapping Screw		
	3 × 6mm Self-Tapping Screw	× 10	
980029	3 × 12mm Self-Tapping Screw		
	3 × 12mm Self-Tapping Screw	× 10	
980030	3 × 5mm Button Head Bolt		
	3 × 5mm Button Head Bolt	× 10	
980031	2 × 8mm Flat Head Screw		
	2 × 8mm Flat Head Screw	× 10	
980032	2 × 10mm Flat Head Screw		
	2 × 10mm Flat Head Screw	× 10	
980033	3mm Spring Washer		
	3mm Spring Washer	× 10	
980034	2mm Flat Washer		
	2mm Flat Washer	× 10	
980035	2.6mm Flat Washer		
	2.6mm Flat Washer	× 10	
980036	3mm Flat Washer		
	3mm Flat Washer	× 10	
980037	2mm Hex Nut		
	2mm Hex Nut	× 10	
980039	3mm Lock Nut (t2.8)		
	3mm Lock Nut (t2.8)	× 10	
980040	4mm Lock Nut		
	4mm Lock Nut	× 10	
980044	2.3 × 40mm Control Rod		
	2.3 × 40mm Control Rod	× 2	
980045	2.3 × 45mm Control Rod		
	2.3 × 45mm Control Rod	× 2	
980047	2.3 × 75mm Control Rod		
	2.3 × 75mm Control Rod	× 2	
980049	Nylon Washer (t 0.5)		
	Nylon Washer (t 0.5)	× 10	
980051	Nylon Washer (t 0.13)		
	Nylon Washer (t 0.13)	× 10	
980067	3 × 3mm Set Screw		
	3 × 3mm Set Screw	× 10	
980068	3 × 15mm Set Screw		
	3 × 15mm Set Screw	× 10	
980078	2 × 13mm Spring Pin		
	2 × 13mm Spring Pin	× 5	

PARTS LISTINGS

Part No	Description	Quantity	Comments
980079	3 × 35mm Socket Head Bolt		
	3 × 35mm Socket Head Bolt	× 10	
980085	2.3 × 55mm Control Rod		
	2.3 × 55mm Control Rod	× 10	
980103	3 × 14mm Self-Tapping Screw		
	3 × 14mm Self Tapping Screw	× 10	
980120	4 × 4mm Set Screw (Nylon Lock Type)		
	4 × 4mm Set Screw (Nylon Lock Type)	× 10	
980121	2.3 × 25mm Control Rod		
	2.3 × 25mm Control Rod	× 2	
980122	3 × 50mm Socket Head Bolt		
	3 × 50mm Socket Head Bolt	× 10	
980127	3 × 22mm Socket Head Bolt		
	3 × 22mm Socket Head Bolt	× 5	
980128	2mm Lock Nut		
	2mm Lock Nut	× 10	
980129	2.6mm Lock Nut		
	2.6mm Lock Nut	× 10	
980131	2 × 10mm Socket Head Bolt		
	2 × 10mm Socket Head Bolt	× 10	
980132	3.5mm CA Stopper Ring		
	3.5mm CA Stopper Ring	× 10	
980146	3 × 10mm Self-Tapping Screw		
	3 × 10mm Self-Tapping Screw	× 10	
980152	3 × 47mm Control Rod		
	3 × 47mm Control Rod	× 2	
981004	5 × 13 × 4 Shielded Bearing (R-1350ZZ)		
	5 × 13 × 4 Shielded Bearing (R-1350ZZ)	× 2	
981005	10 × 19 × 7 Shielded Bearing (L-1910ZZ)		
	10 × 19 × 7 Shielded Bearing (L-1910ZZ)	× 2	
981006	6 × 19 × 6 Shielded Bearing (R-1960ZZ)		
	6 × 19 × 6 Shielded Bearing (R-1960ZZ)	× 2	
981010	Oil-less Metal (B-F4-1)		Centre Hub A
	Oil-less Metal (B-F4-1)	× 2	
981011	Oil-less Metal (B-S3-4)		Seesaw Shaft
	Oil-less Metal (B-S3-4)	× 2	
981013	14mm Stopper Ring		
	14mm Stopper Ring	× 1	
981015	2mm CA Stopper Ring		
	2mm CA Stopper Ring	× 10	
981019	4 × 10 × 4 Shielded Bearing (L-1040ZZ)		
	4 × 10 × 4 Shielded Bearing (L-1040ZZ)	× 2	
981025	5 × 19 × 6 Shielded Bearing (635ZZ)		
	5 × 19 × 6 Shielded Bearing (635ZZ)	× 2	
981029	5 × 10 × 4 Thrust Bearing (T5-10)		
	5 × 10 × 4 Thrust Bearing (T5-10)	× 2	
982180	Body	× 1	
983023	Tail Brace Tube L475		
	Tail Brace Tube L475	× 1	
983067	Tail Boom L716		
	Tail Boom L716	× 1	



Horizon Hobby, Inc.
4105 Fieldstone Rd.
Champaign, IL 61822
www.horizonhobby.com