

組み立て説明書 ASSEMBLING INSTRUCTION



AEROSPATIALE
SA-341G
gazelle
ガゼル

FOR EXPORT



主ローター直径	1,580mm
胴体長	1,420mm
全備重量	5,200g
エンジン	60~61クラス
無線機	4ch
テール	ダクトファン

Main rotor dia.	62-1/5"
Fuselage	55-9/10"
Full-equipped weight	11-12/25 lbs
Engine	60 - 61 class
Radio	4 channels
Tail	Ducted fan

— ASSEMBLING SECTION —

(1). Assembling ENGINE & TRANSMISSION

Symbol of screws
 CS: Cap screw
 SS: Set screw
 PH: Pan head machine screw
 TS: Tapping screw
 FW: Flat washer
 Brg.: Bearing

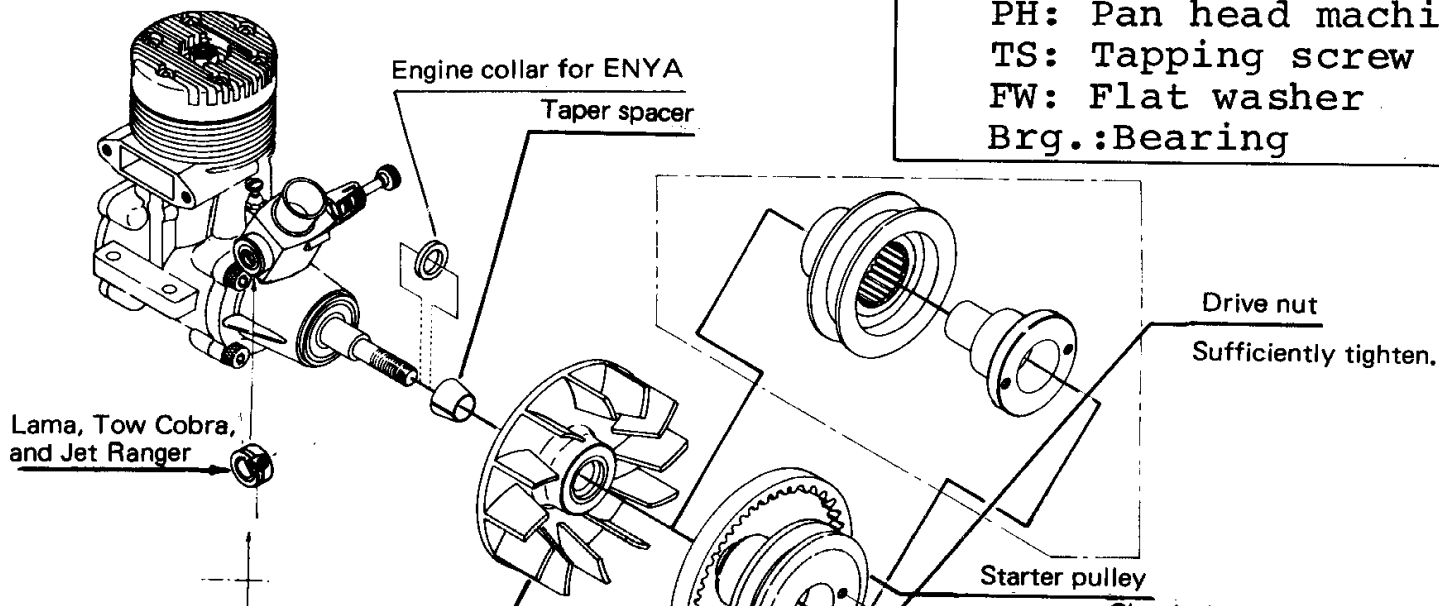

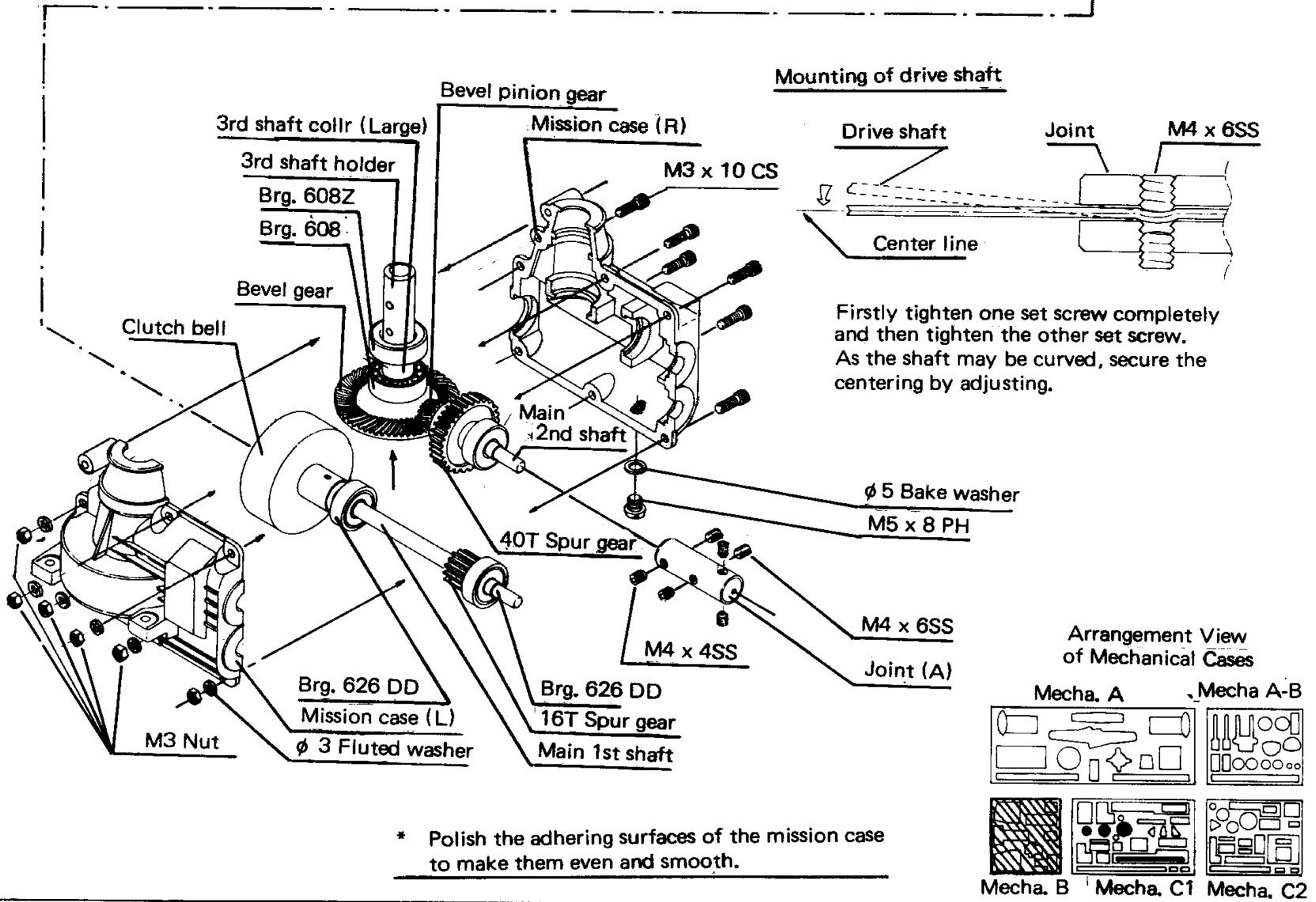
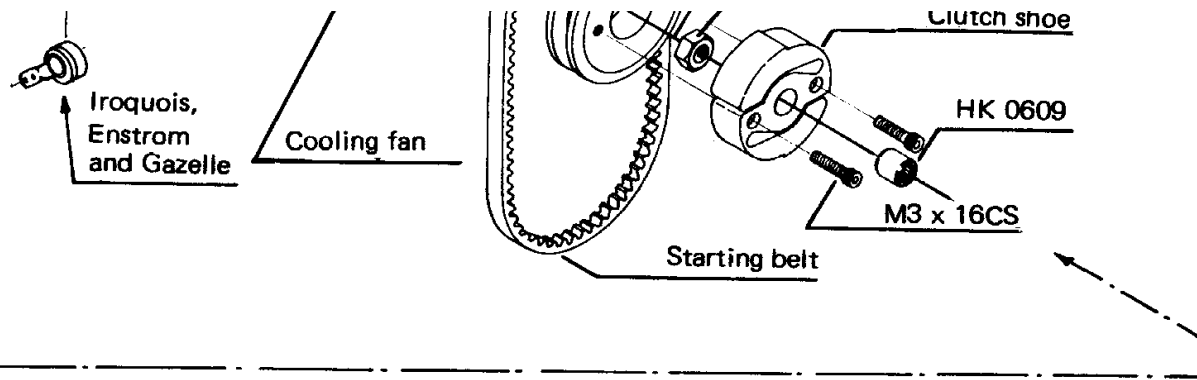

* Polish the adhering surfaces of the mission case to make them even and smooth.

1 Finish the fitting surfaces and the bearing holding. NR-

1. Finish the fitting surfaces and the bearing holding surface of the mission case to be even and smooth. After that, cement the mission case together with epoxi-adhesive and fix it by M3 x 10 cap screws.
2. Supply half (20 to 25cc) of the accessory oil through the lower drain port of the mission case, Then, provide M5x8 Pan head machine screw with a bake washer. After that, screw in the pan head machine screw at the drain port.

ND.

To prevent oil from leaking during assembling, you may supply oil just before trial flying. But in this case, please be careful so as not to forget oiling. It is much recommended that HIROBO HOBBY OIL 50 is used for supplement; This oil is the best quality oil for this purpose since 2 % molybdenum bisulfide (MoS_2) is added).

– 1(A), (B), (C), (F), (G), (H) –

(2) Assembling PITCH UP MECHANISM

View illustrating the completion of the collect pitch up section

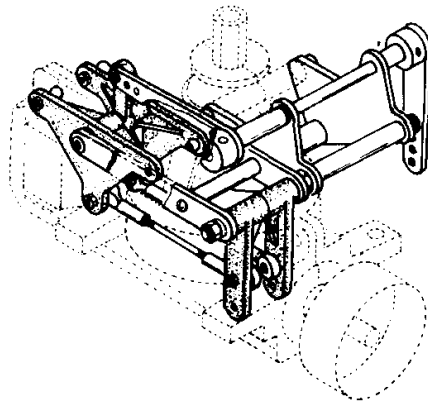

* A = Short (for I AMA)
Collect pitch shaft (A), (B)

Collar (B) and (D) for pitch up
(B) = short, for Lama)

F4 x 6 Bushing

M4 x 6 SS

ø 2 BS Collar

(* (B) = short, for Lama)

Link arm shaft (A), (B)

M4 U Nut

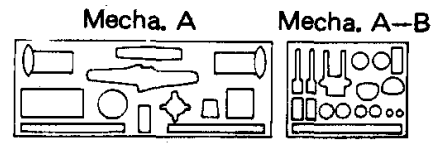
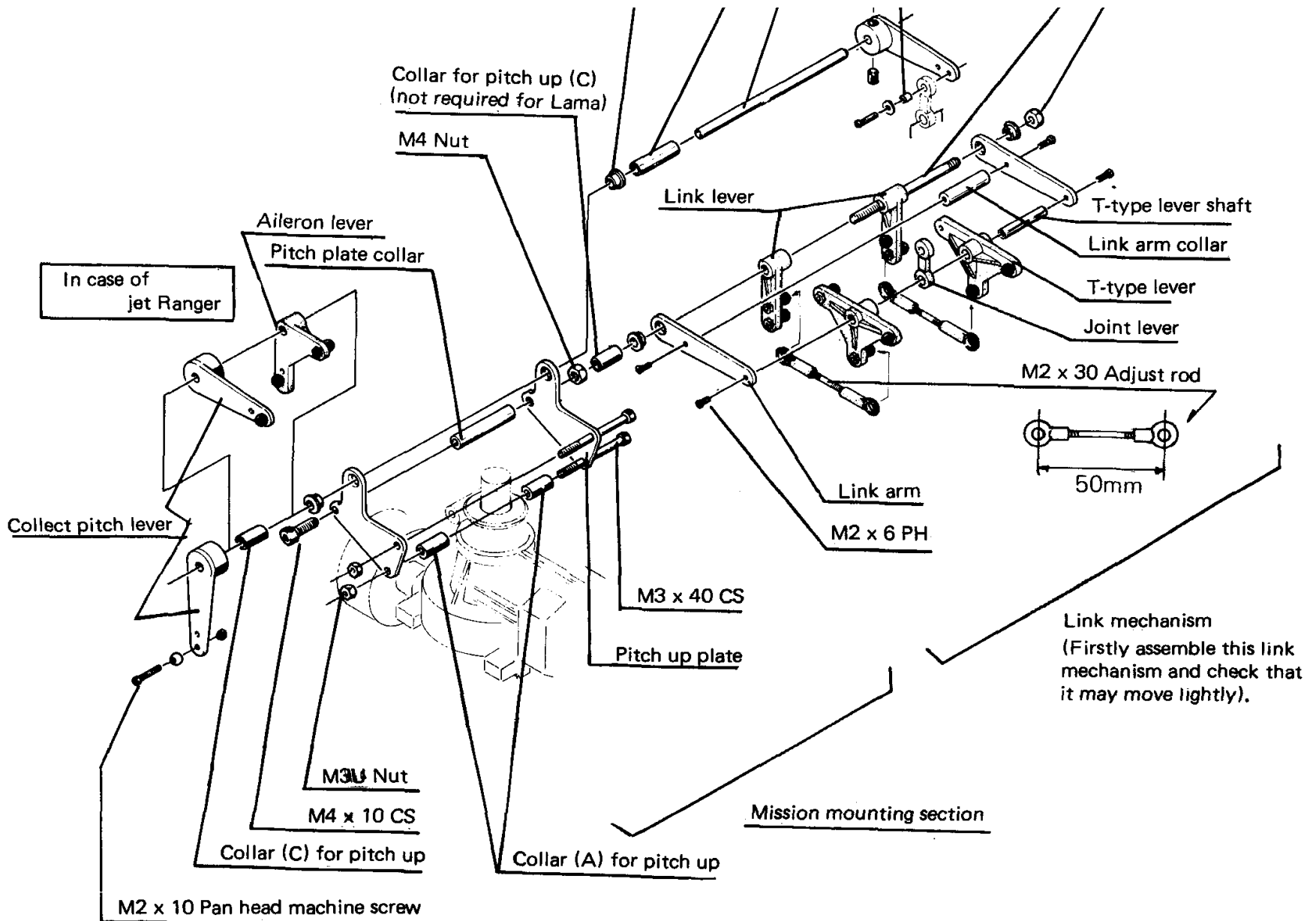

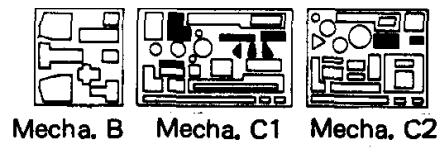

- 2 (A), (B), (C), (F), (G), (H) -

Mounting the gimbal shaft bushing:
 Insert the needle pin to secure the centering. Then, cement it.

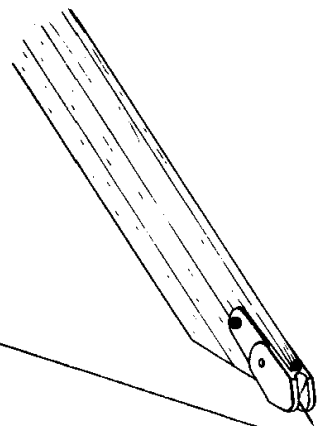

Fix with epoxy-adhesive.
 (The insertion length should not exceed 35 mm).

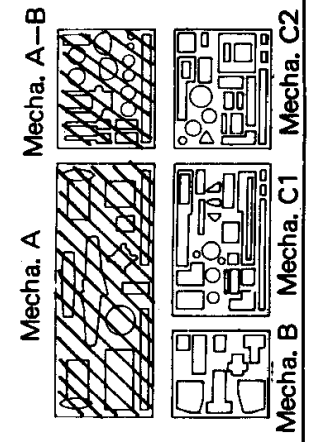
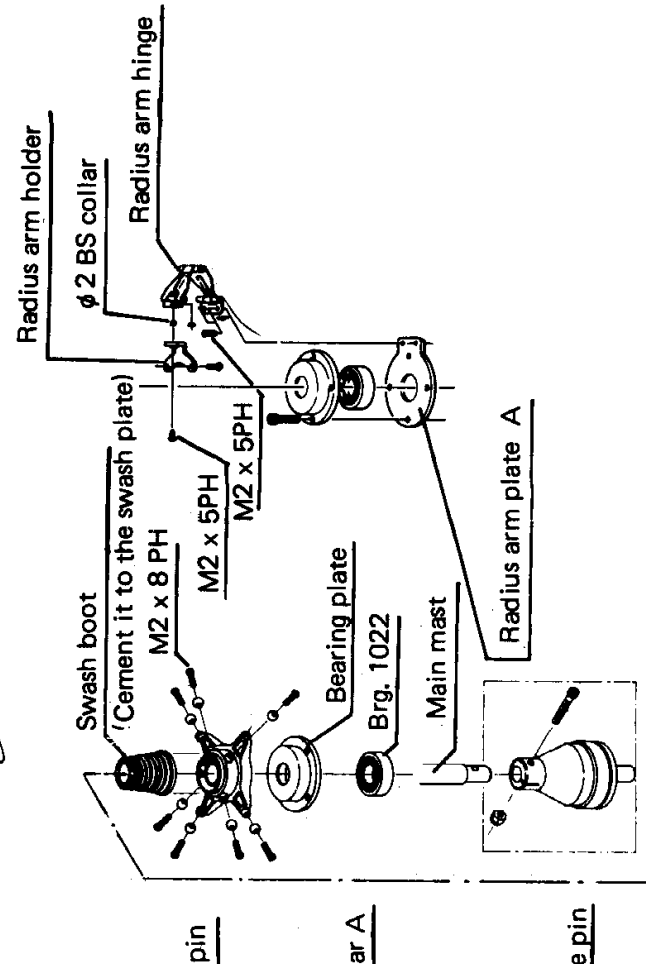
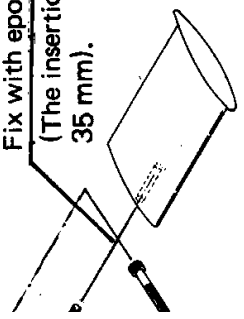

(3-1). Assembling ROTOR HEAD

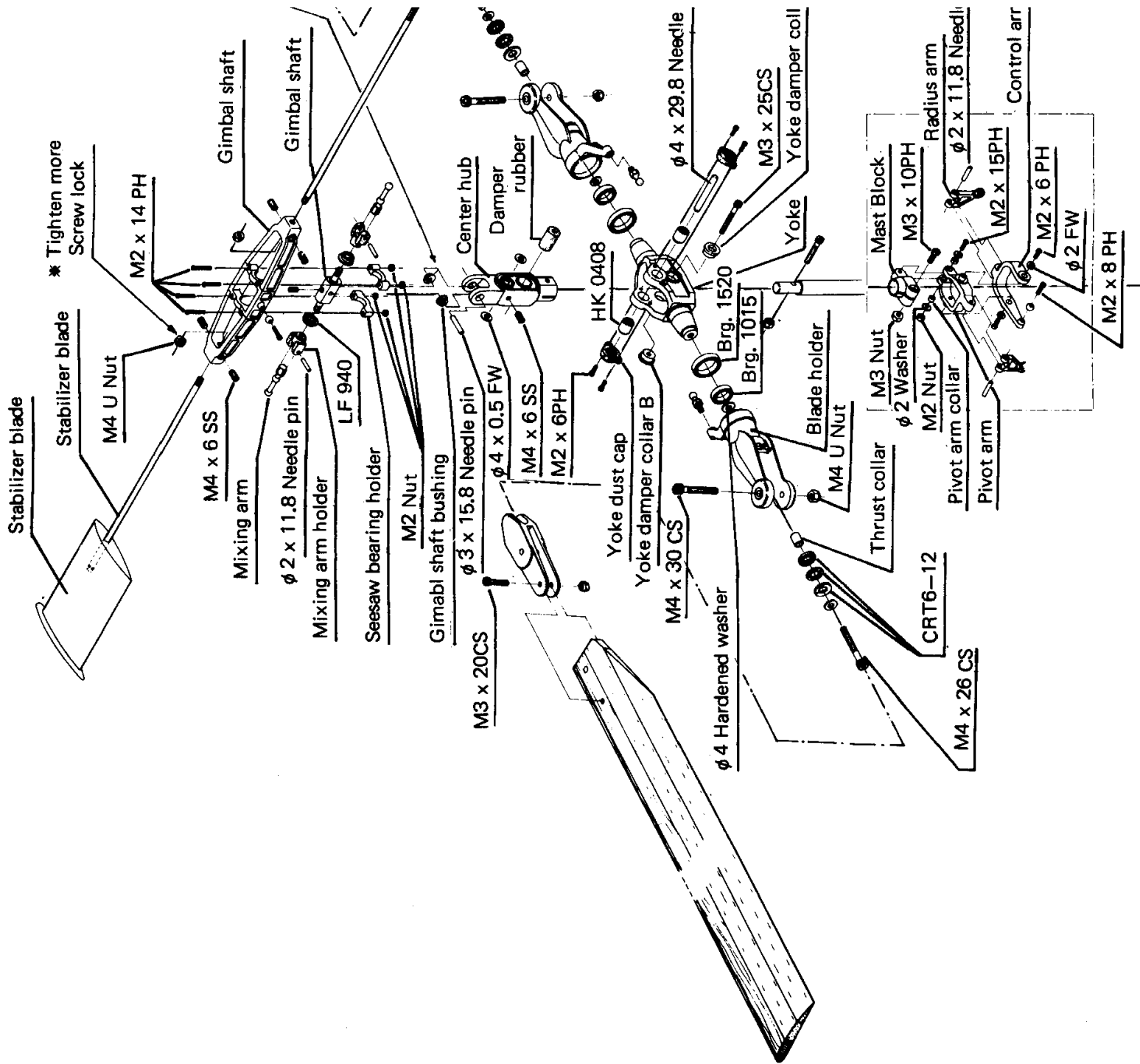

(3-2). Assembling and Adjustment of ROTOR HEAD

Adjust the balance of the stabilizer by controlling the screw-in depth of the stabilizer blade. (the screw-in depth is about 35 mm).
(NB: The balance adjustment should be performed with the rod ends removed.)

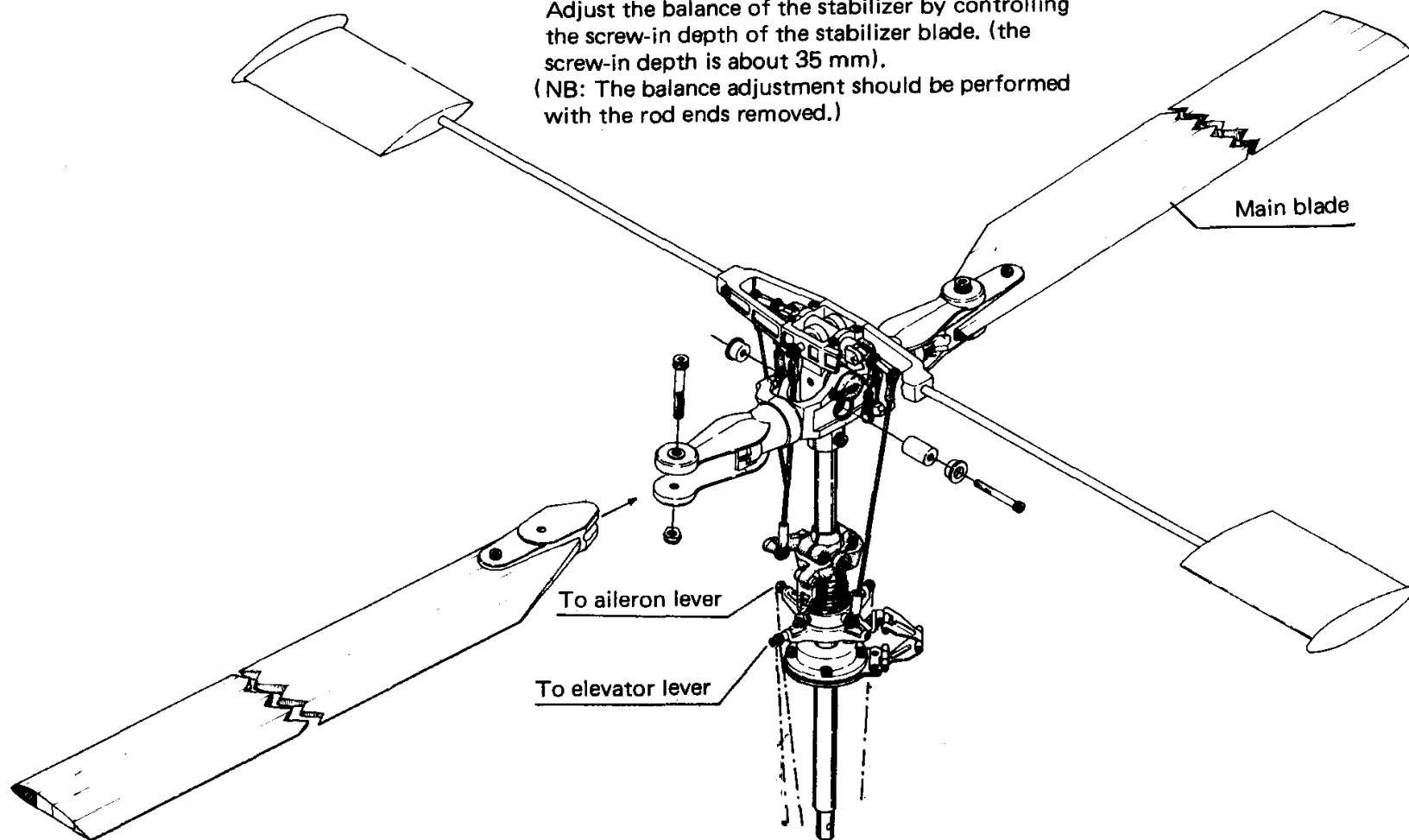

- (1). For 60 Jet Ranger, the radius arm hinge section is mounted at the 45° left forward position.

For all the other models, it is mounted at the 45° left rearward position. (The mounting plate for LAMA is different from that for others).

- (2). For the bearing plate, work or make the upper seat surface of the body so that the mast smoothly rotate. Then, obtain the centering of the mast.

(When mounting an auto-rotation unit of an optional accessory, the centering is especially important.)

REMARKS:

Never fail to check the head section of the helicopter before flying, in order to see if screws or bolts are loosened. If necessary, please replace the components as early as possible.

In case the stabilizer bar, main mast or main blade is damaged, please never fail to check the following points.

- (1). To see if the yoke is damaged or not.
- (2). To see if the blade holder is damaged or not.
- (3). To see if all the screws, nuts or bolts are damaged or not.

If you find anything doubtful, please replace it as early as possible.

(4). Mounting MOUNTING PLATE

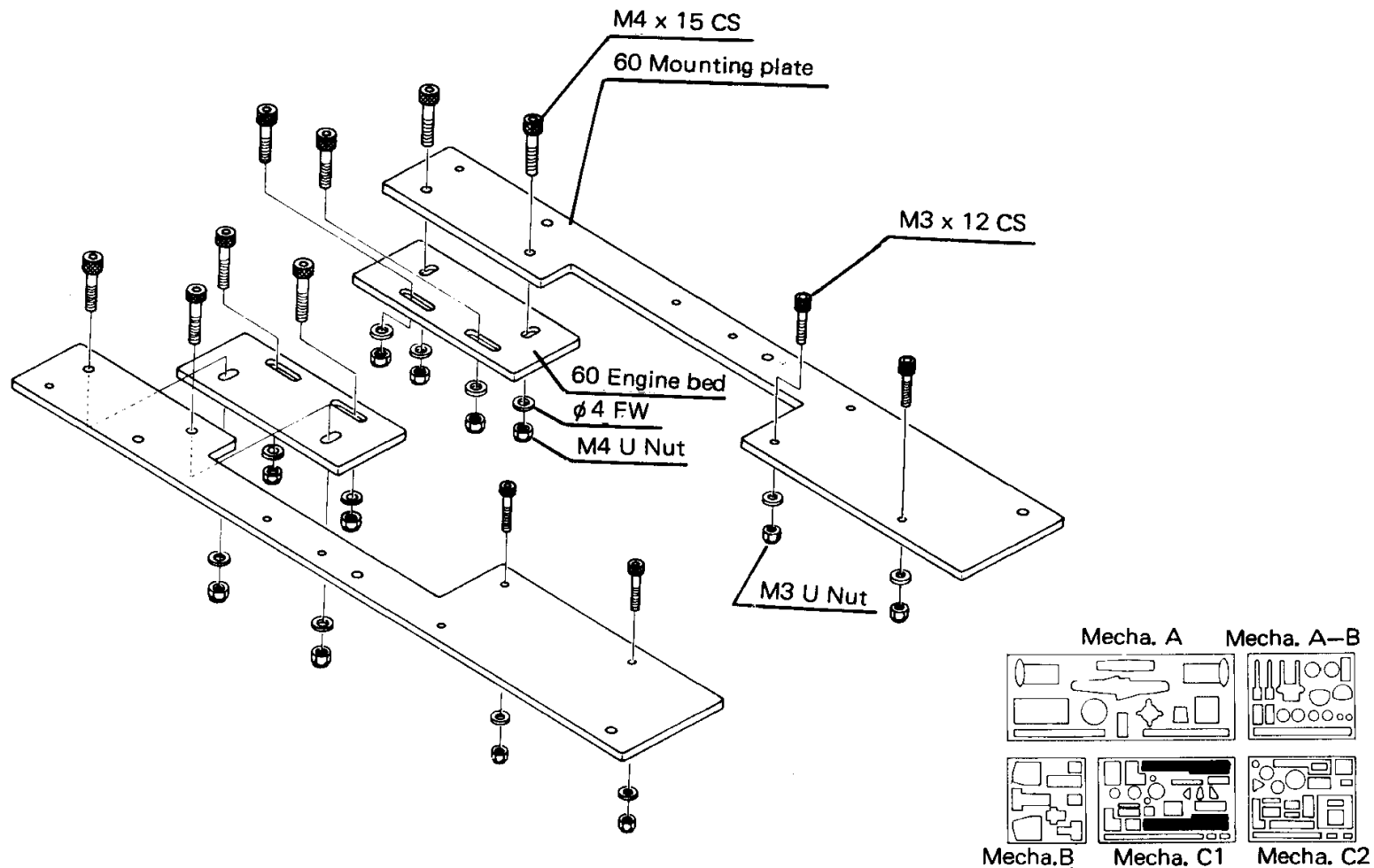

(1). Place the pre-assembled drive mechanism section on the mounting plate. For 60 class helicopter, mount the mounting plate to the wood member from underside and for 50 class helicopter, mount it from the upperside.

(2). When mounting, check that the mast is inclined forwards a little.

(5). Mounting BODY FRAME & Working the COOLING COVER

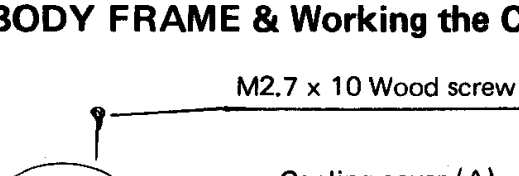

M2.7 x 10 Wood screw

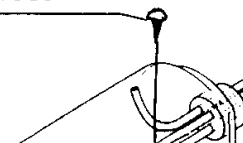

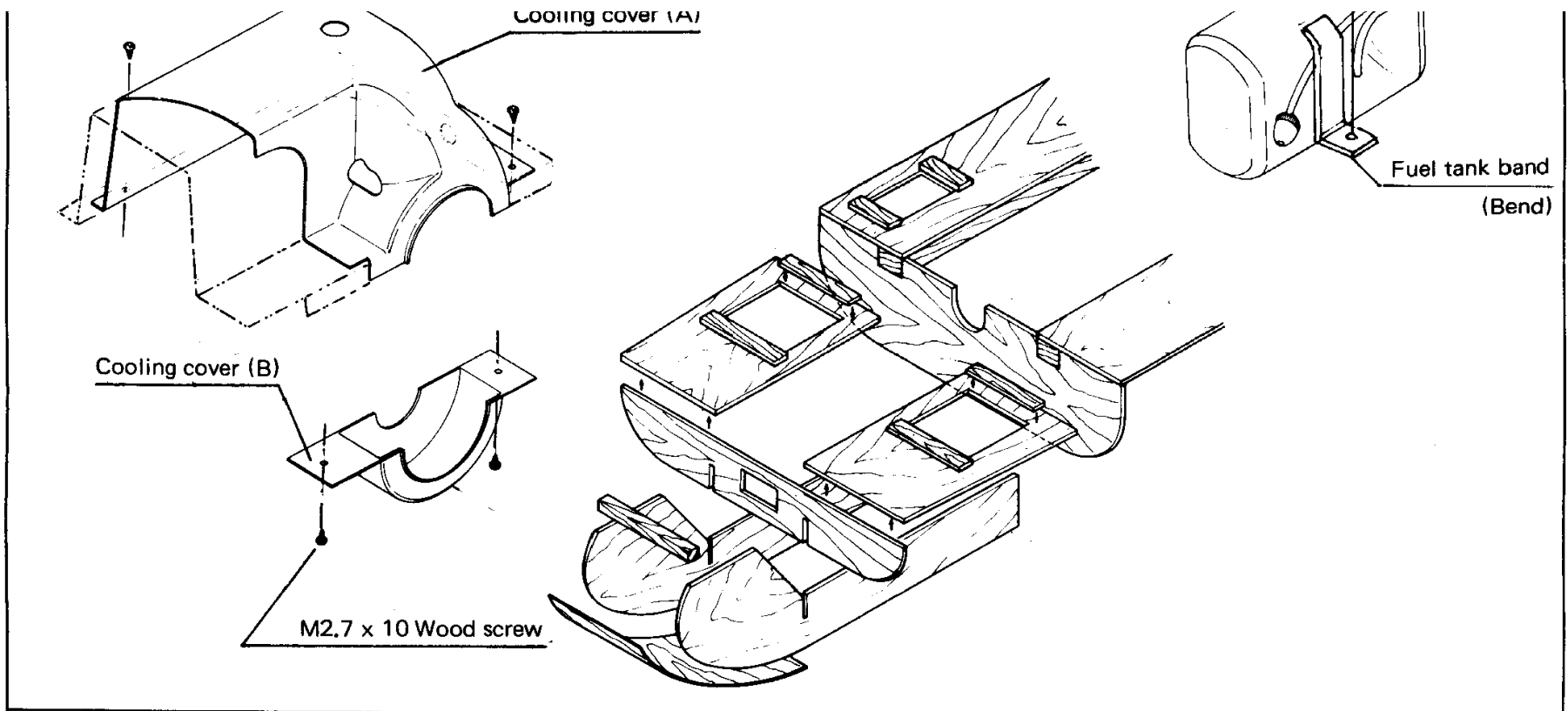

(1) Working the cooling cover:
Cut the cooling cover for the plug hole, needle position and the muffler section to the shape of the engine.

(2). For fuel tank:
Bend the fuel tank band after the tank is mounted in a position. (No band is required for the model Tow Cobra). (The band is fixed by a wood screw.)

(6). Assembling LANDING GEAR

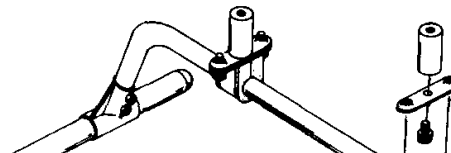

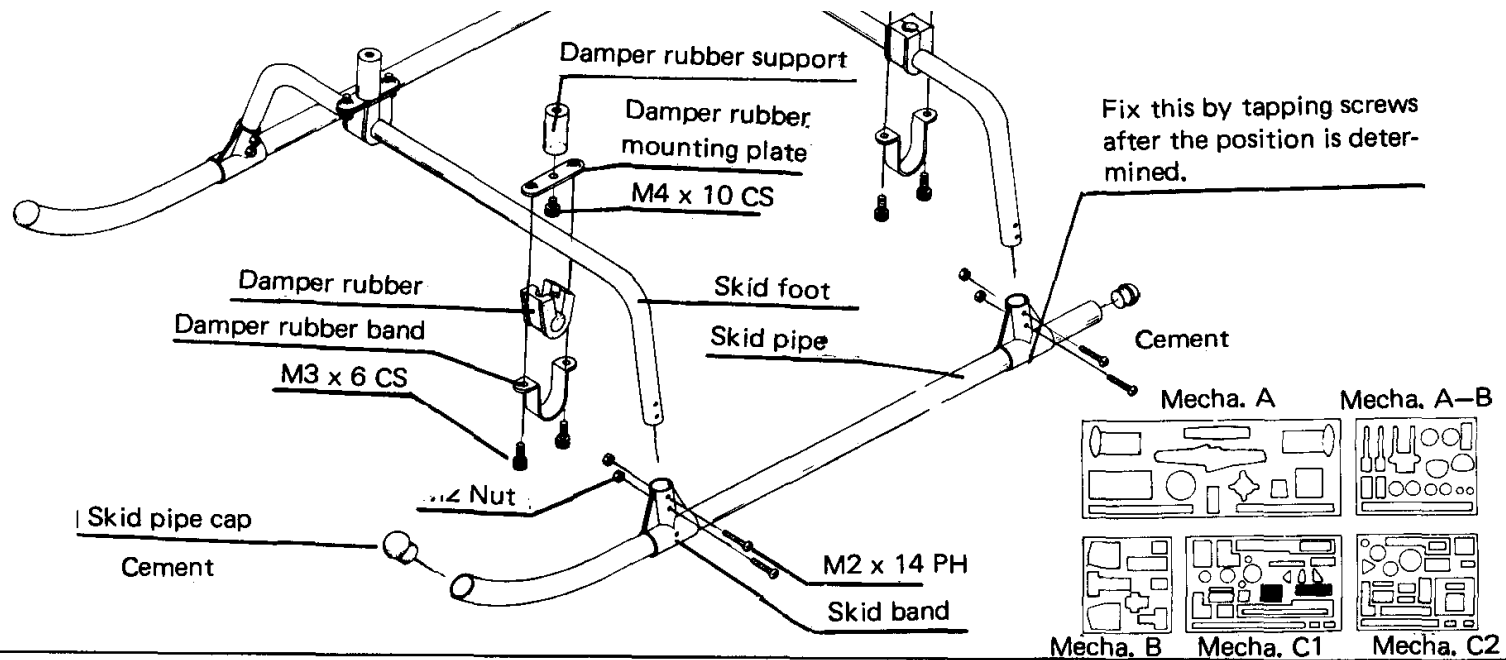

(7)(8) Assembling TAIL SECTION

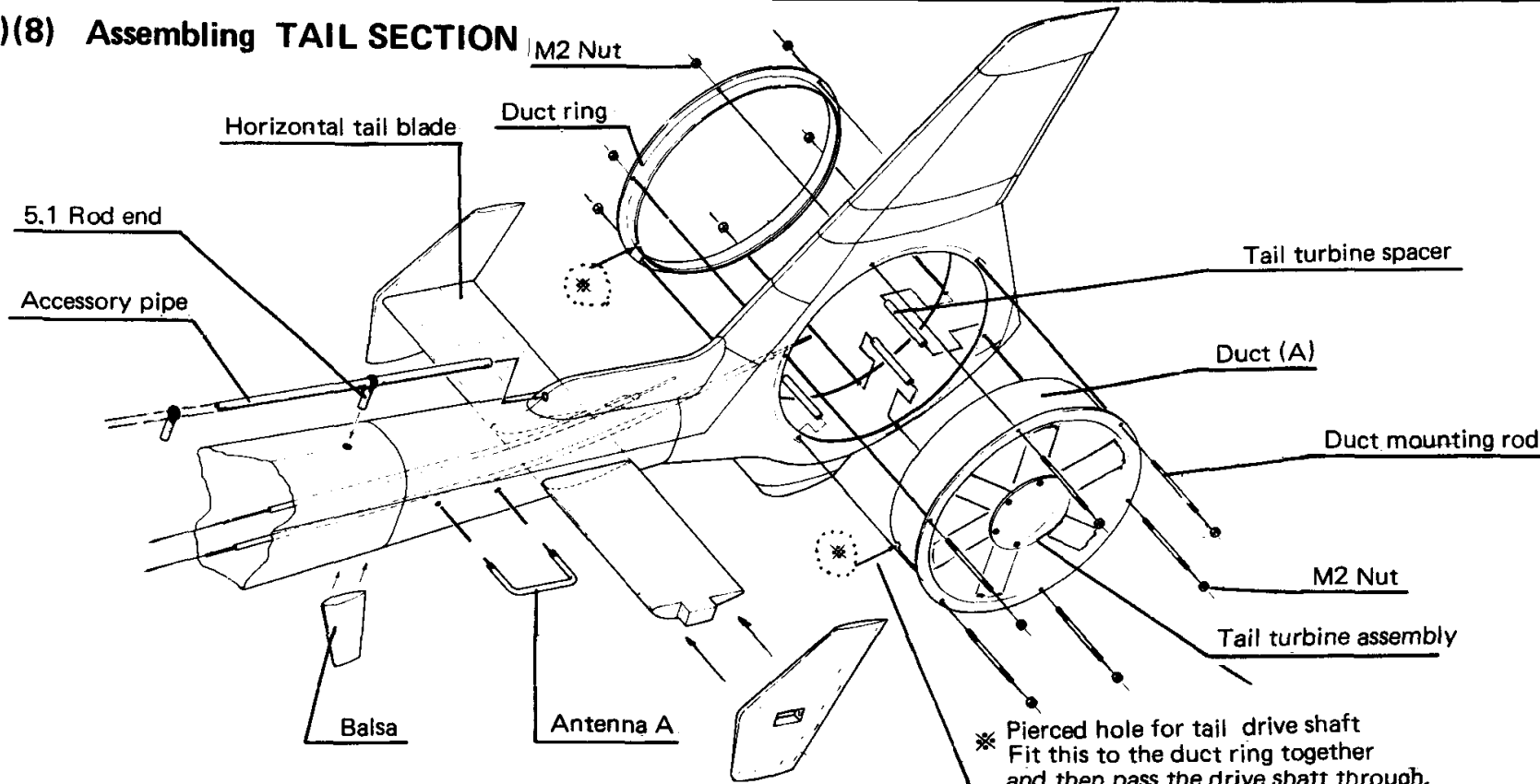

Assembling DUMMY ENGINE

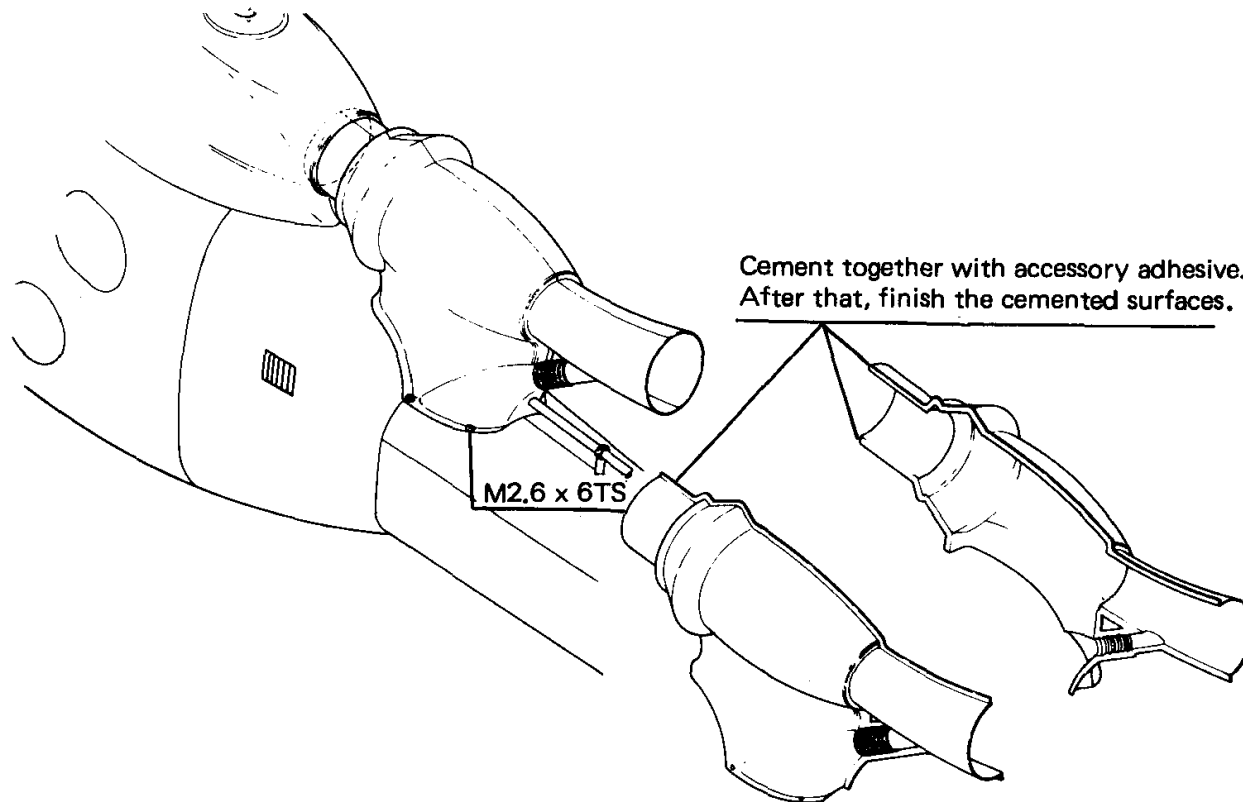

- 6F -

ng	Collar	od end	Tail Pitch hinge	Tail pitch plate	M3 x 3 SS	Tail pitch plate stopper	rg. LF 3-6	∅2 x 8	L)	Mecha. A	Mecha.A-B	Mecha.C1	Mecha. C2
----	--------	--------	------------------	------------------	-----------	--------------------------	------------	--------	----	----------	-----------	----------	-----------

OPTION PART

W type tail blade holder set

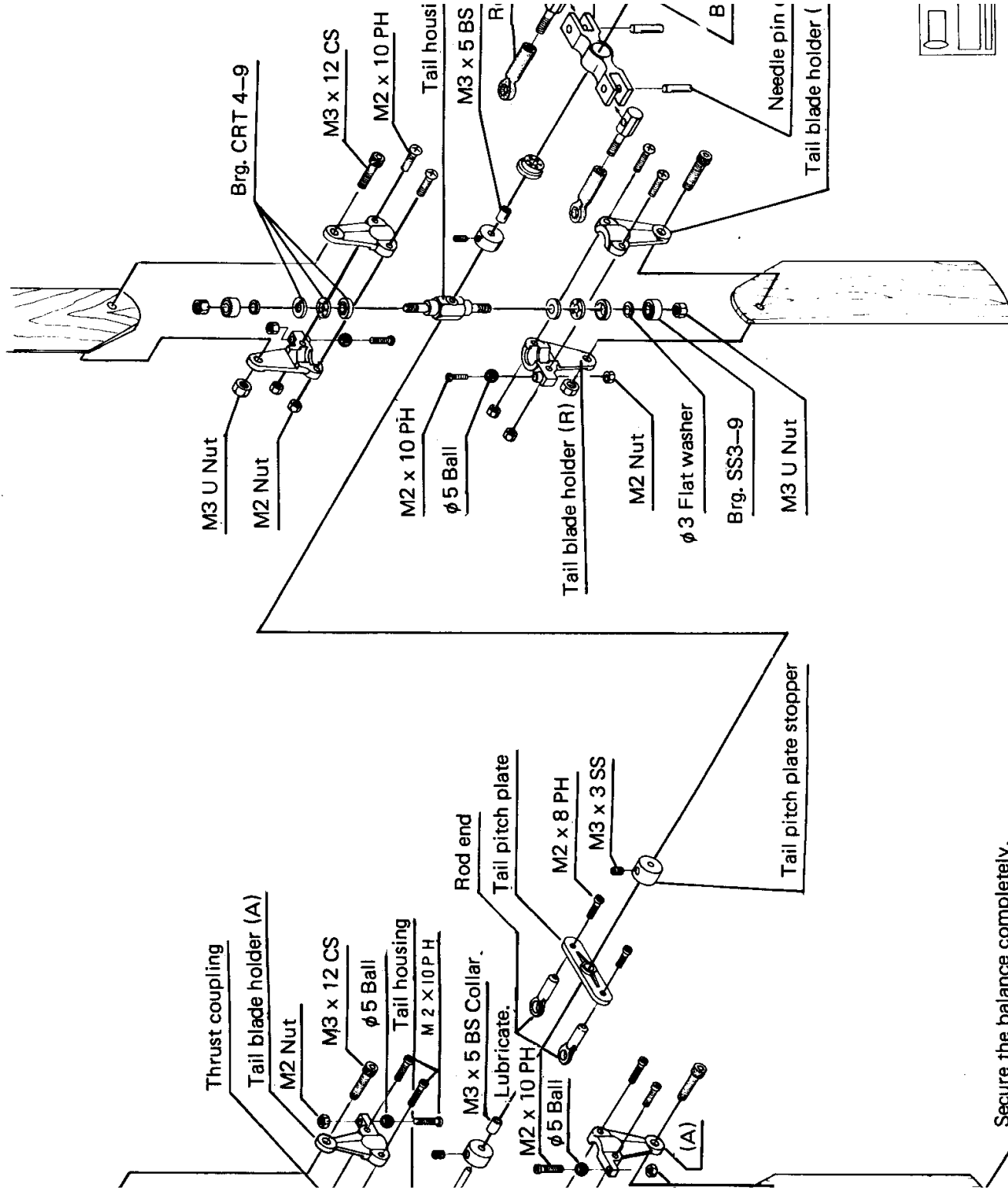

Secure the balance completely.

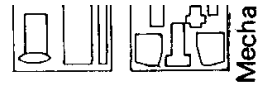

Mecha

(8). Assembling TAIL MISSION

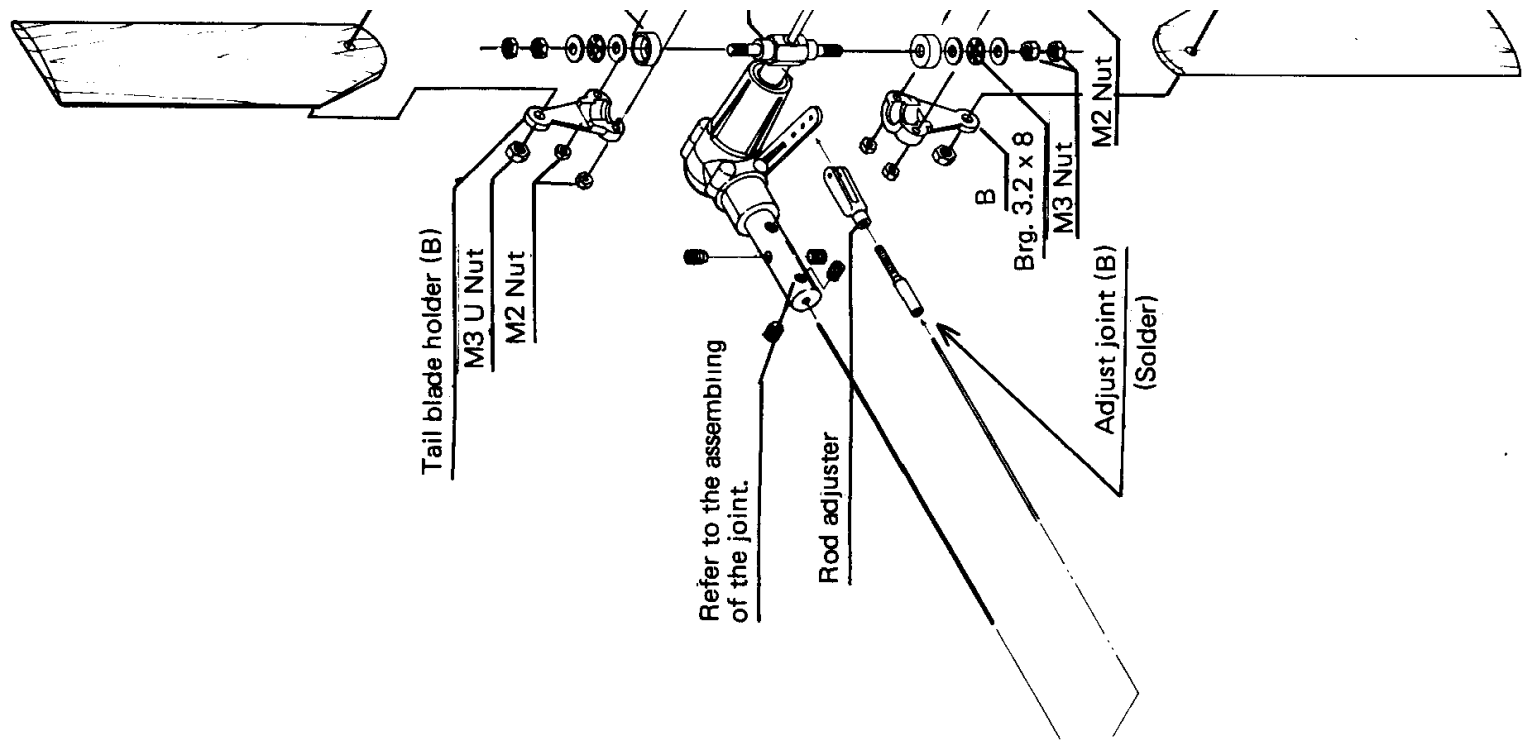

– 7(A), (C), (F), (G), (H) –

(9). Balance Adjustment of Blades

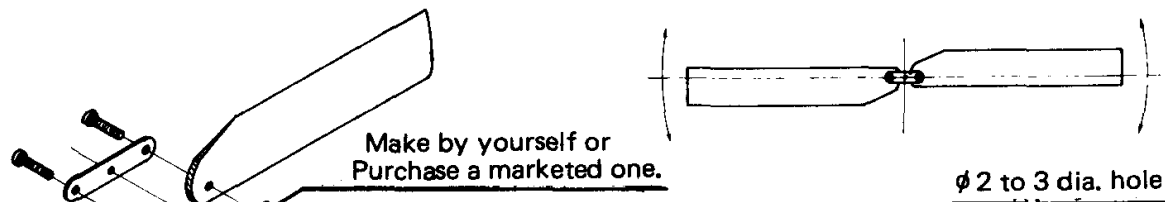

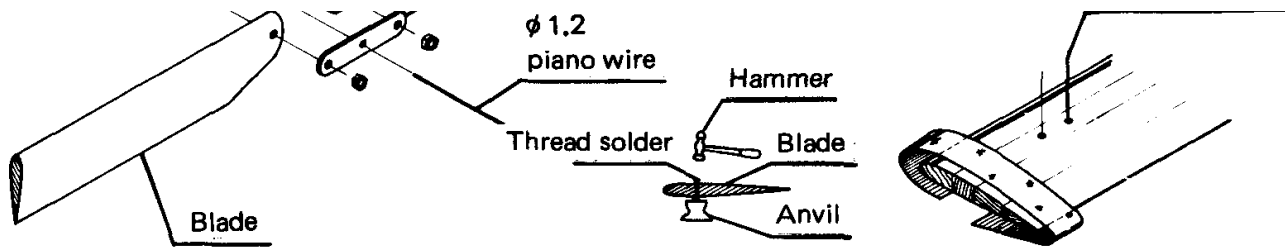

B: In case of 5 servoes:

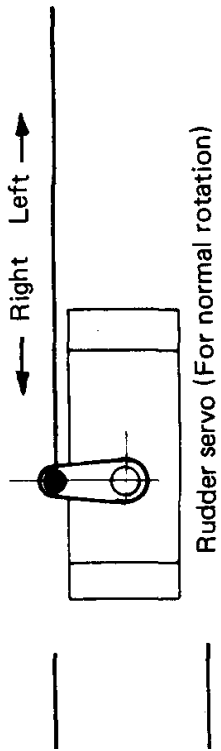

– 8 (A), (B), (C), (F), (G), (H) –

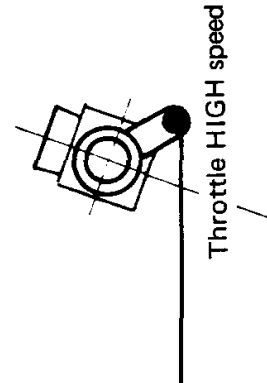
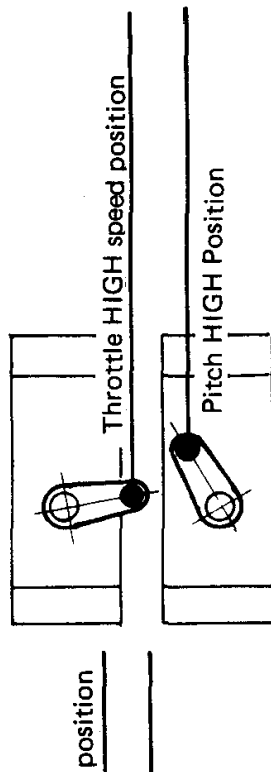

Arrangement View of Servos for GAZELLE

A: In case of 4 servos:

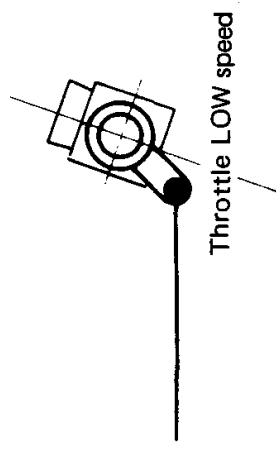
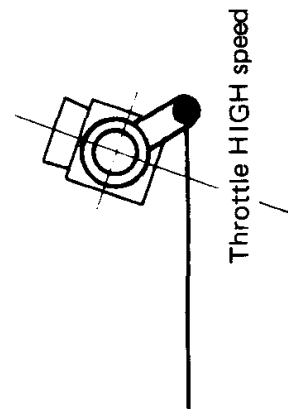
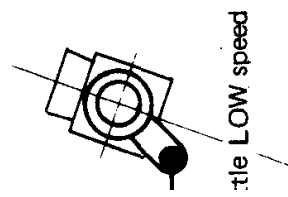
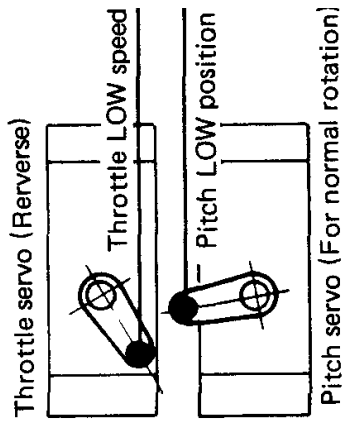
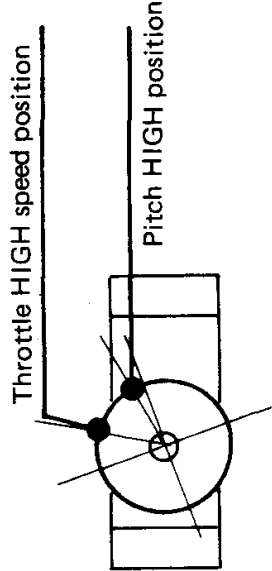
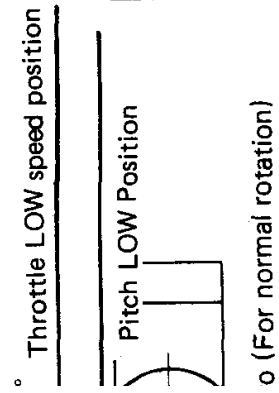
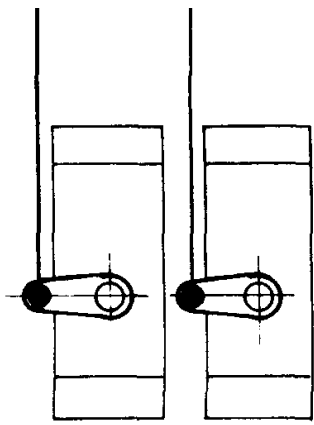
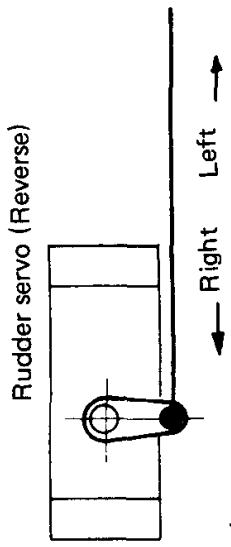
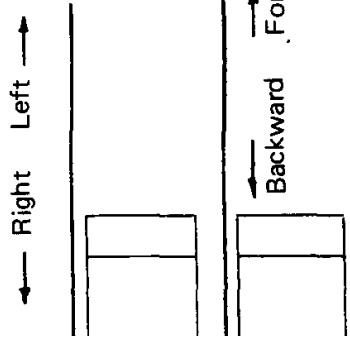

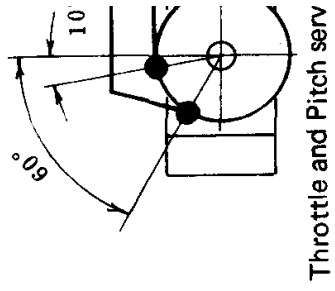
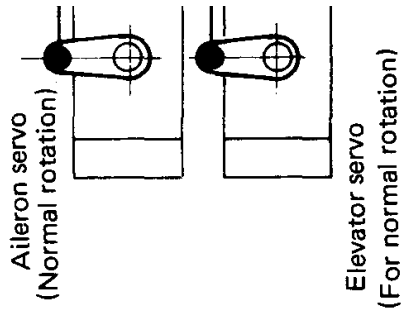

Throt

- 10 (F) -

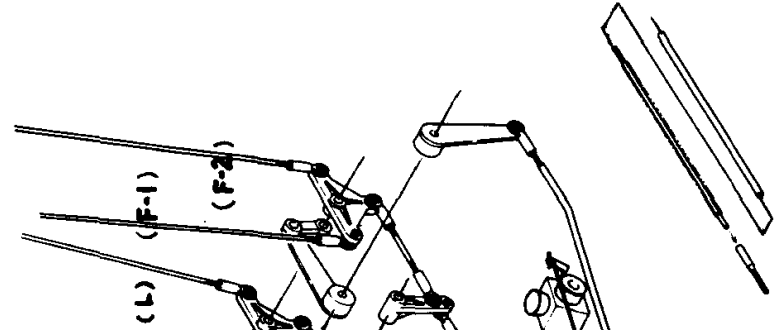
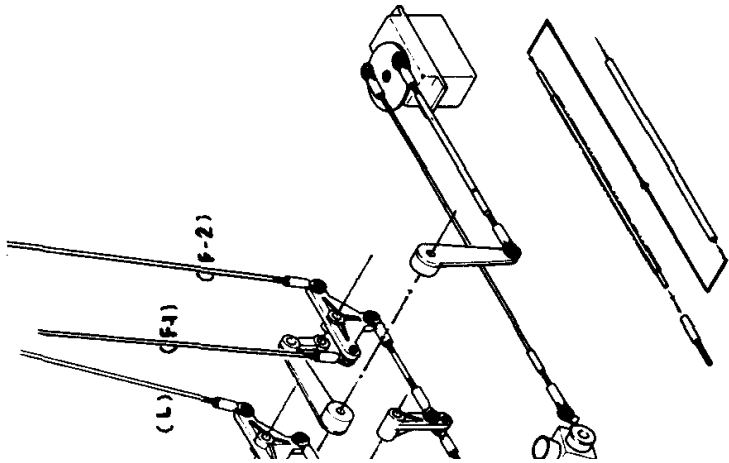

Servo Linkage

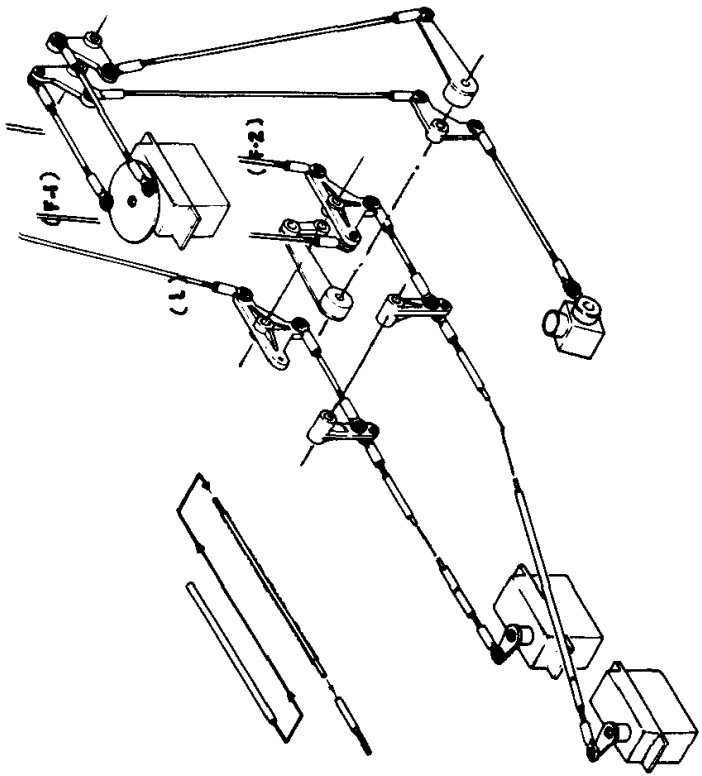

Jet Ranger

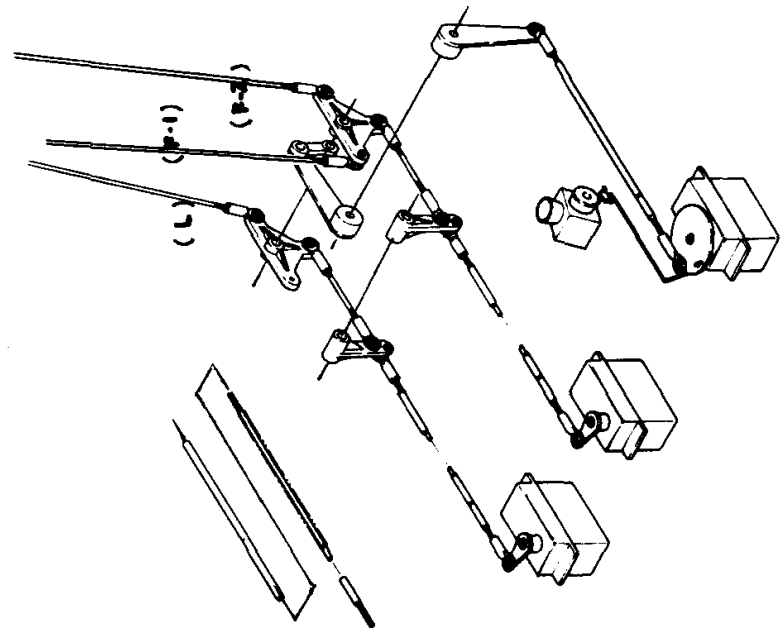

Iroquois, Gazelle, Enstrom,

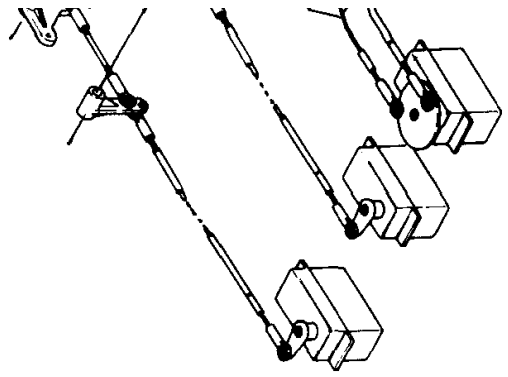
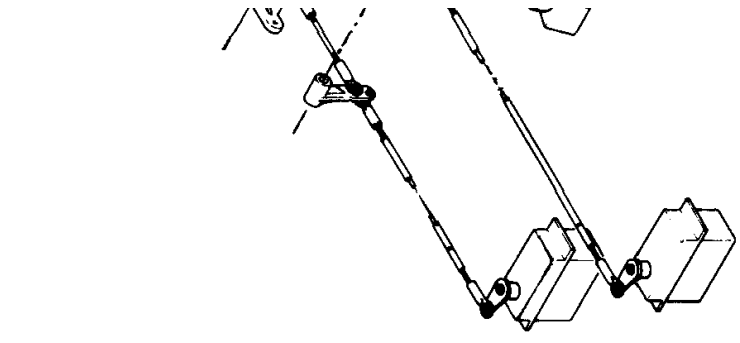

– 11 (A), (B), (C), (F), (G), (H) –

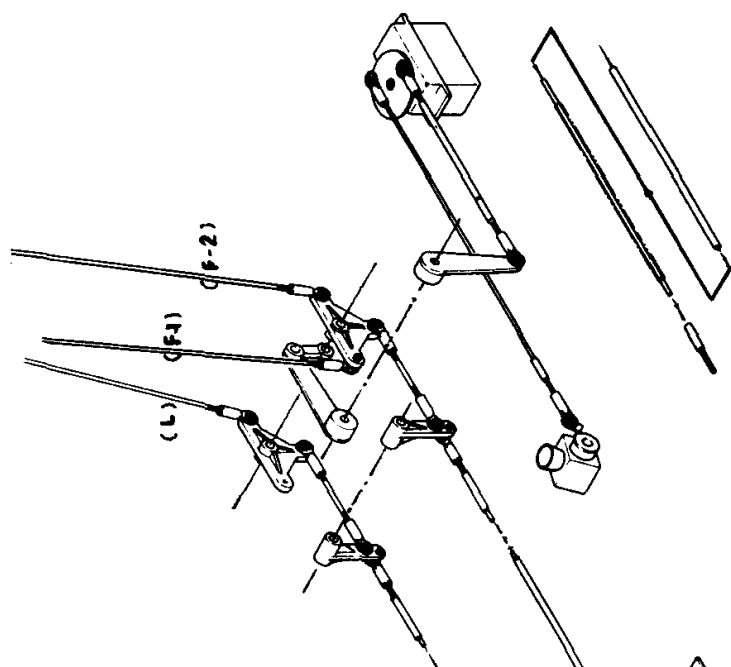

Tow Cobra

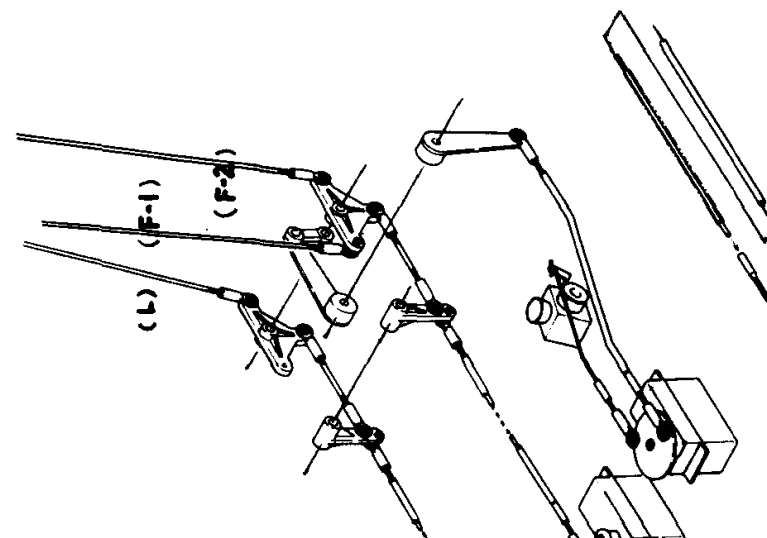

Lama

Servo Linkage

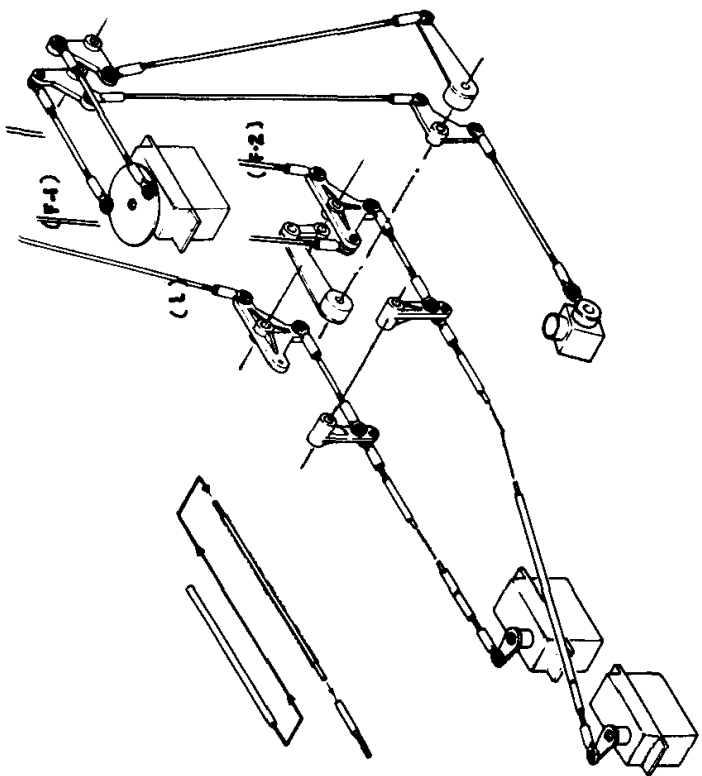

Jet Ranger

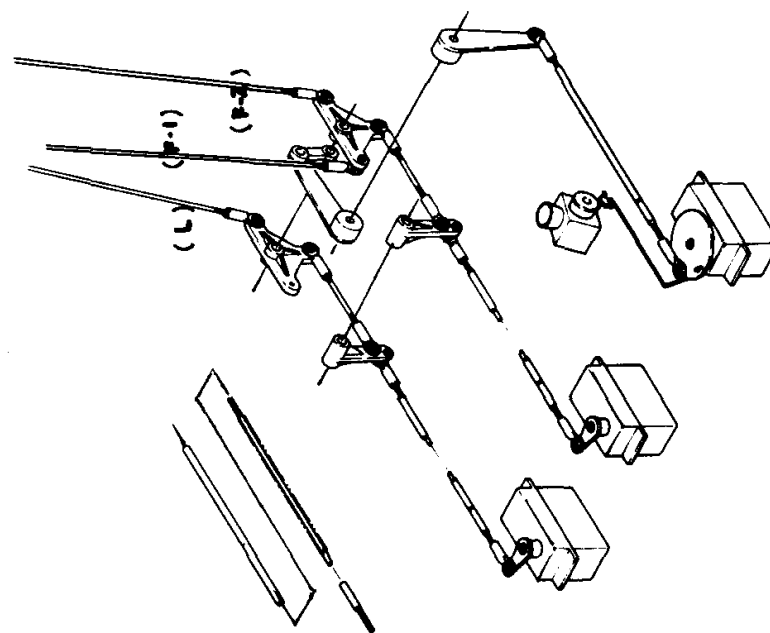
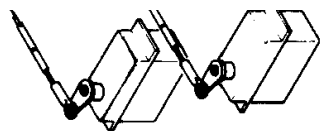

Iroquois, Gazelle, Enstrom,

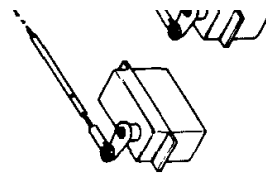

ITCH MIXING

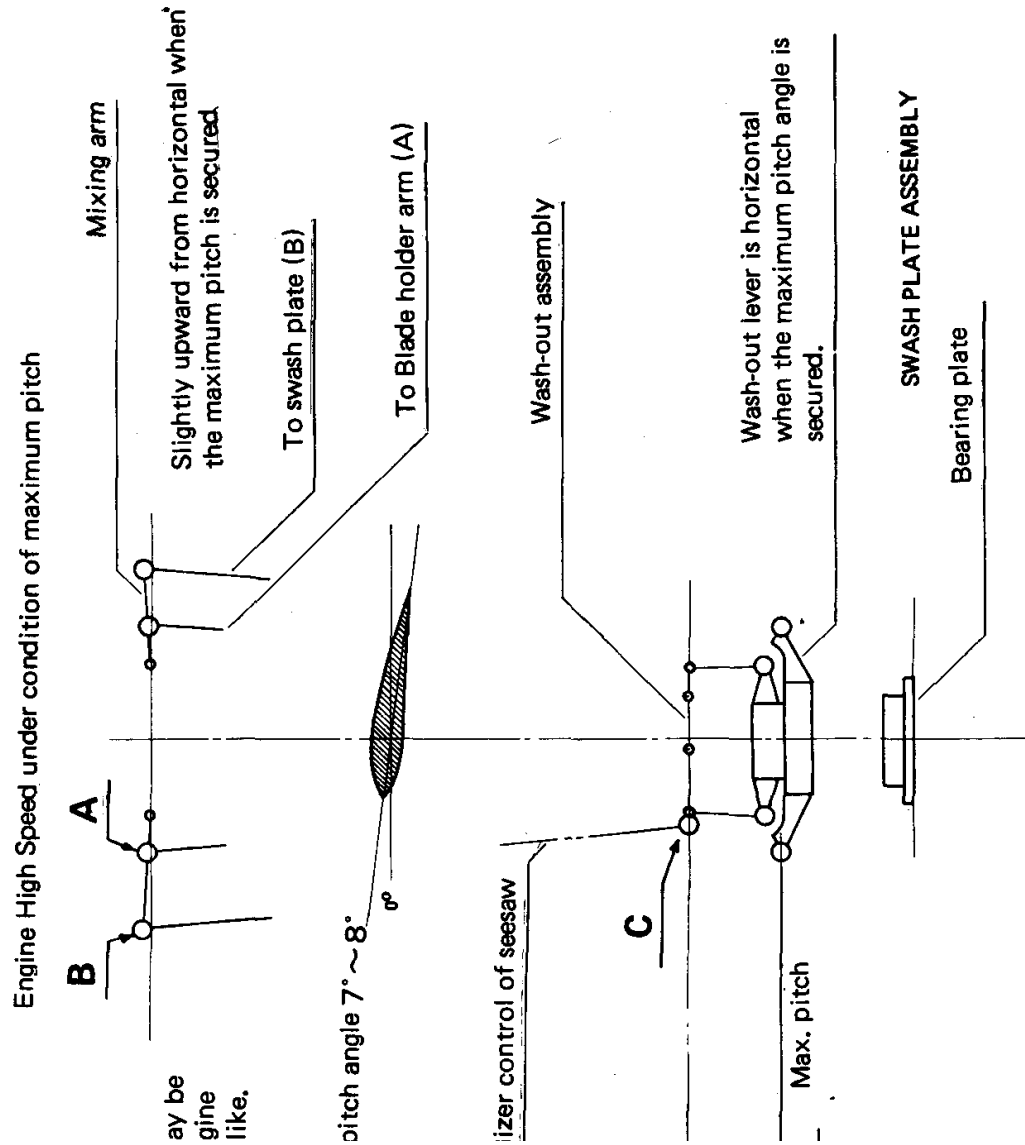

ADJUSTMENT OF MAIN BLADE P

Engine idling under the minimum pitch

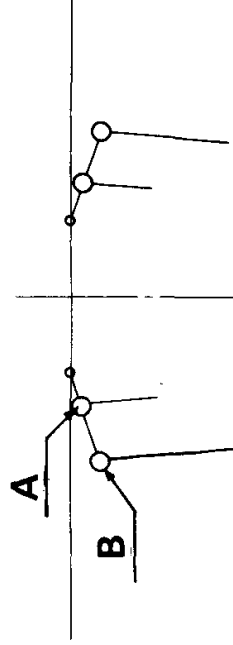

The maximum pitch angle m different according to the en power, kind of fuel, and the

Pitch angle on engine idling

Pitch angle on engine stopping 0° $- 2^{\circ}$

(Auto, Rotation, Landing)

Max. I

To stabil

Semi-symmetrical type main blade

To stabilizer control of seesaw

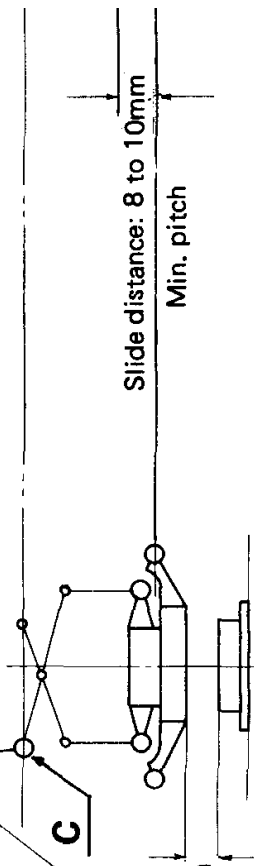

Slide distance: 8 to 10mm

Min. pitch

More than 5 mm

-12 (A), (B), (C), (F), (G), (H), (K) -

ASSEMBLING INSTRUCTION (Supplementary explanation)

■ Mounting the power (drive) section in the body:

Drill a hole of ϕ 12 mm , for passing the mast through , at the upper part of the body after the hole position is well confirmed according to the drawing. Then, place the pre-assembled power section from the underside of the body and mount the mast at the main mission. However, there is no need to make a hole of 3 mm dia for cooling cover because the cooling cover is to be mounted with wood screws.

After the hole is drilled, fix the damper rubber base and its affiliated members by screws. For ENSTROM, insert the power section in the body from its front part and mount it on the wood member.

■ Cautions for mounting the bearing plate:

After the power section is mounted in a position, furnish the mast with the bearing plate and set it so that it may be in soft touch with the upper part of the body. At this time, file the upper part, where the bearing plate is mounted, so that the seat surface of the bearing plate may become completely plane (even).

If this seat surface is not even or inclined, excessive load may be given to the mast assembly with the auto rotation clutch mounted and the auto rotation clutch may be damaged. Please be careful to this point.

■ Painting

Firstly, stick thin paper or silk to the tail blade or other balsa materials with clear lacquer and finish them with the surfacer.

For the FRP body, polish the whole surface of the body by # 240 sand paper. If the body is partially injured, correct it with polyester putty or surfacer. Again polish it with # 300 to 400 sand paper. After that, finish the whole by painting. Use a paint of polyurethane, vinyl chloride, or epoxi type. In case of lacquer-oriented paint, it may be injured by fuel. Therefore, if such a paint is used, finish it with polyurethane or epoxi-oriented clear.

For the part around or near the fuel tank opening and the gear box, give a thick coat of

For the part around or near the fuel tank, engine and the gear box, give a thick coat of polyurethane or epoxy oriented clear to them.

– 13 (A), (B), (C), (F), (H) –

ADJUSTMENT SECTION**A. Mounting the servoes & Adjustment of the linkage****Mounting the servoes:****a. Prepare the servoes as follows:****(1). In case 4 servoes are used:**

Normal-turn servo ----- 3 pcs.

Reverse-turn servo ----- 1 pc.

(2). In case 5 servoes are used:

Normal-turn servo ----- 4 pcs.

Reverse-turn servo ----- 1 pc.

b. Paying attention to the rotation direction and the mounting position of the rod, mount the servoes in accordance with the arrangement view of the servoes and the drawing.**c. Neutral position of servo horn**

Switch on the transmitter and the receiver and set the trim to the central position.
(For engine and pitch control, keep the stick and the trim of the transmitter to the lowest position.)

Working and mounting the push-pull rod.

To protect the push-pull rod from being distorted, furnish it with the BS pipe and solder both ends of the rod. (The length of the push-pull rod is to be determined to the following explanations).

a. Aileron , elevator

(1). Link the aileron/engine servo with the pitch up link lever by a M2 x 290 adjust rod. Determine the length by cutting the unthreaded end of the rod. Then, solder the adjust joint (A).

(2). Screw in the rod end and decide the length so that the link lever may become perpendicular at the neutral position.

b. Engine throttle rod

(1). Loosen the SLOW adjust screw about two turns for the engine carburetter and adjust it so that the engine may can completely stop. (Please refer to the instruction manual of the engine which you purchased.)

(2). Mounting the rod at the servo horn : (please refer to the arrangement view of the servoes).

(Use a servo horn whose shape is of disc type).

(i). Mounting angle

On idling ----- About 60° position from the lateral center line

(ii). Mounting radius

Full OPEN/Full CLOSE stroke of the carburetter = Rod mounting stroke.

— 14 (A), (B), (C), (F), (G), (H) —

(3). Transmitter stick, Lowest, Trim, Lowest ----- Engine stops

Transmitter stick, Lowest, Trim, Intermediate --- Idling

Transmitter stick, Highest, Trim, Intermediate --- Throttle, Full OPEN

c. Collect Pitch

Mounting the rod at the servo horn:

(i). Mounting angle

On Idling ----- About 10° from the lateral center line.

(ii). Mounting radius

The position where the slide distance of the collect pitch of the adjustment view of the rotor head mixing can be secured. (Vertical slide distance of the swash plate)

d. Rudder control

(1). Neutral position of the rudder servo

Intermediate position of the engine control stick (in case of prop with mixing for helicopter)

(2). Neutral position of the tail pitch lever

Set the neutral position of the tail pitch lever a little gear box side from the intermediate point of the whole movable range.

(3). Working the control wire:

Solder an adjust joint at one end of the control wire and furnish it with a rod end.

Then, pass it through the control pipe. After that, determine the length and cut off.

Solder the adjust joint. Then, provide it with another rod end.

The part exposed from the control pipe is to be reinforced by soldering.

ADJUSTMENT OF SERVO LINKAGE

Begin adjusting the linkage of each servo after the rods are mounted at each servo.

- a.** Switch on both transmitter and receiver. Set the trim lever of the transmitter to its mean point. Check the rotation direction of each servo. Then, check that the horn of each servo is set at the neutral position.

NB: For the aileron/elevator, check that the link lever of the pitch up mechanism is vertical.

- b. The relationship between the swash plate and control rod is as follows:

Aileron:	Lever (L) point	Swash plate (L) Point	Rod (L) point
Elevator:	Lever (F-1) Point	Swash plate (F-1) Point	Rod (F-1) Point
Elevator:	Lever (F-2) Point	Swash plate (F-2) Point	Rod (F-2) Point

Mount the swash plate and the control rod in a position by screwing in the rod ends to M2 both-side threaded screw rods of the designated dimension of each helicopter. At this time, adjust the swash plate so that it may be horizontal (have a right angle to the mast in both forward/backward and left/right directions) and that the clearance between the upper surface of the bearing plate and the lower surface of the swash

– 15 (A), (B), (C), (F), (G), (H) –

plate may be 5mm to 6mm . For this purpose, control the length of the rods by the screw-in distance of the rod ends.

- B. Linkage of the rotor head

Rod (A)	Plate holder (A)	Mixing arm (A)
Rod (B)	Swash plate (B)	Mixing arm (B)
Rod (C)	Wash-out (C)	Seesaw (C)

- a. Mount the rod (A) by uniformly screwing in the rod ends at both ends of the M2 x 16

screw..

b. Rod (B)

Switch on the transmitter and lift up the engine control lever to the highest position to shift the swash plate for maximum pitch. Then, furnish the M2 rod of the designated dimension of each helicopter with a rod end. Adjust the length of the rod so that the mixing arm may become a little upward with the seesaw kept horizontal.

c. Rod (C)

Fix the wash-out to the mast so that the control arm of the wash-out may become horizontal under the conditions described in (b).

NB:

Fix the wash-out at the position where four horns of the lower side of the swash plate may be piled up on the four horns of the upper plate with the rotor blade placed on the center line of the body (i.e. body length direction).

For the rod, furnish the adjust rod of the designated dimension of each helicopter with rod ends by screwing in, lead it to the wash-out (C) point through the seesaw (C) point and the inside of the yoke.

At this time, bend the rod near the wash-out so that it may not come in contact with the yoke. And adjust the length of the rod so that the stabilizer blade may become horizontal.

BALANCE ADJUSTMENT OF ROTOR BLADE

a. Main rotor blade

The main rotor blade rotates at high speed. So, if complete balance is not secured, poor ruddering and/or vibrations may be caused to be present. Therefore, obtain complete balance of the main rotor blade.

First of all, place a round pencil or a mast on an even table or so. Then, put the two blades on it. Under these conditions, roll the pencil or the mast to look into the center of gravity

of the blade in the length direction. Then, mark the center of gravity with a pencil or so. Check that the center of gravity of the two blades is located at the same position. If error more than 5mm is caused, make an opening of 2mm dia. at the tip or the root of the lighter blade and caulk a thread type solder in the opening to true up the centers of gravity of the two blades.

– 16 (A), (B), (C), (F), (G), (H) –

Next, adjust the balance of the weight of the two blades. At this time, use a blade balancer to secure complete balance of the blades.

b. Tail rotor blade

As the tail rotor blades rotate at the speed of 4,000 to 6,000 rpm., secure complete balance of the tail rotor blades by the same method as that for the main rotor blades.

c. Protection of the blades

As the weight balance of the blades may change to the humidity content in the air, stick the adhesive tape (film) to the blade surfaces to protect it from humidity.

Do the same in the tail blades.

d. **Coloring of blade ends of the main rotor:**

It is impossible to adjust the tracking of the main rotors if it is not possible to distinguish the tracks of the blade ends of both right and left blades. So, provide the blade ends with a distinguishable color tape.

e. **Adjusting the pitch angle of the main blade:**

Switch on both transmitter and receiver. Set the engine control trim to the intermediate position (Idling) and set the stick to the lowest position.

Next, Hold the stabilizer bar with your hands to make the seesaw horizontal. Check that , when observed from the rotor blade end, the line connecting the front end of the blade section surface with the rear end is parallel to the stabilizer bar. If not, adjust the rod (A) (the inside point (A) of the mixing arm – the blade holder (A) point) so that the line may become parallel to the stabilizer bar. At this time, the blade pitch angle is zero (0).

f. **Adjusting the maximum pitch angle**

Since the maximum pitch angle may change to the engine output and the fuel , it is adequate that the maximum pitch angle is set to 7 to 8⁰ degrees of angle in usual cases. Measure it by a pitch gauge. The standard judgement is as follows; For 60 mixing arm, if the distance along which the swash plate lets the mast slide when moving the engine control stick from the lowest to the highest is 10mm, the maximum pitch angle may be roughly 8⁰. For 50 mixing arm, if the distance is 7mm, the maximum pitch angle is 8⁰.

– 17 (A), (B), (C), (F), (G), (H) –

g. Adjusting the tail rotor pitch angle

The following description covers the adjustment of the tail pitch when the mixing prop for helicopter is used. (Please refer to the instruction manual of the transmitter). Set the knob for tail mixing adjustment , of the transmitter, to the intermediate position and set the engine control stick a little upward from the mean point. (Hovering position). At this time, check that the horn of the rudder servo is located at the neutral position.

Loosen the screws of the tail pitch plate stoppers and shift the pitch plate so that the pitch angle of the tail blade may become zero (0° degree) with the engine control stick lowered to the lowest position.

Adjust the length of the rudder servo horn so that the tail rotor may move by 35 to 40° in either direction when controlling the rudder control stick in each direction with the engine control stick set to the hovering position.

C CHECKS AND INSPECTION BEFORE FLYING

For the center of gravity

The center of the gravity is to be so located that the skid pipe may be a little inclined forward from the horizontalness when holding the stabilizer bar by your hands.

Never locate the center of gravity so that the skid pipe may be inclined backwards.

Checking each point before flight

Adjusting the blades and tracking

Supply fuel in the tank. Check that the engine control lever of the transmitter is set to SLOW position and the trim lever of the transmitter may be set to IDLE position.

After that, start the engine.

After the engine starts, firmly hold the rotor head and step on the skid. Then, race the engine with loud roar two or three times. At this time, if the head tries to rotate strongly, the clutch is completely engaged. If you feel it a little weak, immediately slow down the engine. Try to touch the clutch bell (be careful for overheating). If the bell is heated, cool it by waste cloth or water. Never engage the clutch with high temperature left. (because the clutch shoe is made of resin).

When the clutch bell is cooled to be normal, again try to do setting it for complete meeting.

After the meeting(engagement) of the clutch shoe is checked, gradually increase the rotation speed of the engine. At this time, if the tip ends of the main rotor can be doubly seen when the helicopter is going to land off, distinguish the color of the two rotors to see which blades is higher than the other. In this case, screw in the rod end of the rotor rod (A) of a rotor which goes undersides. Through these procedures, adjust the two main rotors until they can be seen single.

After the tracking adjustment is completed, slow down the engine for idling and check

– 18 (A), (B), (C), (F), (G), (H) –

the pitch angle is zero (0° degree). If not so, adjust by screwing in the rod ends of both rods (A) by the same turns.

D. ADJUSTMENT OF FLIGHT

After that tracking adjustment is completed, begin to adjust the trims.

First of all, for the beginners, bend both ends of aluminum pipe or bamboo and mount them to the landing skid by vinyl tape or the like to prevent the helicopter from barrel roll.

Adjustment of each trim

Gradually increase the rotation speed of the engine to float the helicopter body by 10 to 20 cm from the ground level. If the helicopter moves forwards or backwards, use an elevator trim for correction. Or if the helicopter is inclined in the right and left direction, use the aileron trim for correction. For the rudder, use the rudder trim for correction, too. Adjust the length of each rod so that the helicopter may be floated with the trim lever set to NEUTRAL.

In case of the rudder, loosen the screw of the tail pitch plate stopper and take the pitch

In case of the rudder, loosen the screw of the tail pitch plate stopper and take the pitch plate outside if the trim lever is located right. To the contrary, if the trim lever is located left, take the pitch plate inside for rudder adjustment. For further details, please refer to the instruction manual of the mixing prop which you use.

FLIGHT (In case of beginner)

Fill the tank with fuel after the whole adjustment is completed, in order to be ready for landing off. But wait a moment. breathe deeply and set your mind at ease. Pay a great attention to the neighbors, childrens or the surroundings. After the safety of the surroundings is confirmed, start the engine and turn the head of helicopter windwards.

If you stand back of the helicopter, you can not observe the posture of helicopter in the elevator direction, causing the control to become impossible. Therefore, please stand at the side of the helicopter.

Confirm the safety of the surroundings again. Gradually increase the rotation speed of the engine . Here, if the helicopter moves backwards, set the elevator trim to a little forward side so that the helicopter lands off as moving forwards.

Gradually increasing the rotation speed of the engine, the body begins to be floated from the rear part of the landing skid. At this time, increase the engine control stick by two or three units, and the helicopter advances as being floated.

At first, please don't float the helicopter more than 30cm high. If it is too high, lower the engine control stick to land the helicopter. Then, float it again and walk together with the helicopter. After you reach the end of the yard as repeating the floating and landing of the helicopter, bring it back to the start point. If the control is effected only in one side of the engine, a vice may be caused to be present. Exercise at both sides of the helicopter. Lateral inclination is corrected by aileron , forward/backward inclination by

PARTS ARRANGEMENT & NAME OF PARTS FOR 60 GAZELLE

The table below shows the parts of the drawings and of the illustrations and the arrangement number of the parts in the parts case.

Arrange-ment no. of parts	Parts Number	Parts Particulars	Quantity required
DF-(1)	DF1-1	Expert stabilizer blade	1
DF-(2)	DF2-1	Expert stabilizer blade	1

Remarks

The quantity and quality of the kits have been well checked and inspected before shipment. However, if you should find anything inconvenient, please immediately inform the head office or the shop, where you purchased, together with the parts number eg. DF-0-0.

The specifications shall be subject to change without any prior

			DF-1
Arrange-ment no. of parts	Parts Number	Parts Particulars	Quantity required
DF-(9)	DF9-1	Swash upper plate	1
	DF9-2	Swash lower plate	1
	DF9-3	Swash inner ring A	1
	DF9-4	Swash inner ring B	1
	DF9-5	Bearing 20-25	1
	DF9-6	SF-10	1
	DF9-7	M2 x 6 Pan head machine screw	4
	DF9-8	Swash lower lock	1
DF-(10)	DF10-1	Bearing plate	1
	DF10-2	Bearing 10-22	1
DF-(11)	DF11-1	Stabilizer bar (A)	2
PARTS ARRANGEMENT OF CASE A-B			
	DFB-1	Mixing arm	1
	DFB-2	Mixing arm	1
	DFB-3	Mixing arm holder	1
	DFB-4	Mixing arm holder	1
	DFB5A	Seesaw Bearing Holder	2
	DFB5B	Gimbal shaft	1
	DFB-6	LF940	1
	DFB-7	LF940	1
	DFB-8	Yoke damper collar A	1
	DFB-9	Yoke damper collar B	1
	DFB-10	Yoke dust cap	1
	DFB-11	Yoke dust cap	1
	DFB-12	M2 x 16 Rod screw	2
	DFB-13	HK0408	1
	DFB-14	HK0408	1
	DFB-15	Gimbal shaft bushing	1

notice.

Arrange-ment no. of parts	Parts Number	Parts Particulars	Quantity required
MECHANICAL CASE A			
DF-(1)	DF1-1	Expert stabilizer blade	1
DF-(2)	DF2-1	Expert stabilizer blade	1
DF-(3)	DF3-1	Gimbal seesaw	1
DF-(4)	DF4-1	Main blade root end	2
	DF4-2	Blade holder	2
	DF4-3	Yoke	1
	DF4-4	Bearing 10-15	2
	DF4-5	Bearing 15-20	2
	DF4-6	Thrust CRT6-12	2
	DF4-7	∅ 4 Hardened washer	2
	DF4-8	∅ 4 Washer	2
	DF4-9	Thrust collar	2
	DF4-10	M4 x 25 Cap screw	2
DF-(5)	DF5-1	Center hub	1
DF-(6)	DF6-1	Radius arm	2
	DF6-2	Mast block	1
	DF6-3	Control arm	1
	DF6-4	Pivot arm	1
DF-(7)	DF7-1	Main mast	1
DF-(8)	DF8-1	Swash plate boot	1
MECHANICAL CASE B			
DF-(20)	DF20-1	Mission case L	1

DFB-16	Gimbal shaft bushing	1
DFB-17A	Adjust rod M2 x 70	1
DFB-17B	Adjust rod M2 x 100	2

PARTS ARRANGED IN LOWER SECTION OF CASE A-B

DF-(12)	DF12-1	M3 x 16 Cap screw	5
	DF12-2	M3 x 20 Cap screw	3
	DF12-3	M3 x 25 Cap screw	1
	DF12-4	M4 x 30 Cap screw	2
	DF12-5	M2 x 6 Pan head machine screw	6
	DF12-6	M2 x 8 Pan head machine screw	9
	DF12-7	M2 x 14 Pan head machine screw	4
	DF12-8	M2 x 15 Pan head machine screw	1
	DF12-10	M3 x 10 Pan head machine screw	1
	DF12-11	M2 Nut	5
	DF12-12	M3 Nut	1
	DF12-13	M3U Nut	9
	DF12-14	M4 U Nut	4
	DF12-15	M4 x 4 Set screw	1
	DF12-16	M4 x 6 Set screw	5
	DF12-17	∅ 2 Flat washer	2
	DF12-18	∅ 4 Flat washer	2
	DF12-19	∅ 3 Flat washer	4
	DF12-20	Damper rubber	1
	DF12-21	Rod end	10
	DF12-22	∅ 5 Ball	7
	DF12-23	Pivot bolt A	2
	DF12-24	Pivot arm collar	2
	DF12-25	Needle pin ∅ 2 x 11.8	4
	DF12-26	Needle pin ∅ 3 x 15.8	1
	DF12-27	Needle pin ∅ 4 x 29.8	1

PARTS ARRANGEMENT & NAME OF PARTS FOR 60 GAZELLE

The table below shows the parts of the drawings and of the illustrations and the arrangement number of the parts in the parts case.

Arrangement no. of parts	Parts Number	Parts Particulars	Quantity required
DF-(1)	DF1-1	Expert stabilizer blade	1
DF-(2)	DF2-1	Expert stabilizer blade	1

Remarks

The quantity and quality of the kits have been well checked and inspected before shipment. However, if you should find anything inconvenient, please immediately inform the head office or the shop, where you purchased, together with the parts number eg. DF-0-0.

The specifications shall be subject to change without any prior notice.

DF-1

Arrangement no. of parts	Parts Number	Parts Particulars	Quantity required
DF-(9)	DF9-1	Swash upper plate	1
	DF9-2	Swash lower plate	1
	DF9-3	Swash inner ring A	1
	DF9-4	Swash inner ring B	1
	DF9-5	Bearing 20-25	1
	DF9-6	SF-10	1
	DF9-7	M2 x 6 Pan head machine screw	4
	DF9-8	Swash lower lock	1
DF-(10)	DF10-1	Bearing plate	1
	DF10-2	Bearing 10-22	1
DF-(11)	DF11-1	Stabilizer bar (A)	2
PARTS ARRANGEMENT OF CASE A-B			
	DFB-1	Mixing arm	1
	DFB-2	Mixing arm	1
	DFB-3	Mixing arm holder	1
	DFB-4	Mixing arm holder	1
	DFB5A	Seesaw Bearing Holder	2
	DFB5B	Gimbal shaft	1
	DFB-6	LF940	1
	DFB-7	LF940	1
	DFB-8	Yoke damper collar A	1
	DFB-9	Yoke damper collar B	1
	DFB-10	Yoke dust cap	1
	DFB-11	Yoke dust cap	1
	DFB-12	M2 x 16 Rod screw	2
	DFB-13	HK0408	1
	DFB-14	HK0408	1
	DFB-15	Gimbal shaft bushing	1
	DFB-16	Gimbal shaft bushing	1
	DFB-17A	Adjust rod M2 x 70	1
	DFB-17B	Adjust rod M2 x 100	2
PARTS ARRANGED IN LOWER SECTION OF CASE A-B			

Arrange-

Item no. of parts	Parts Number	Parts Particulars	Quantity required	DF-(12)	DF12-1	M3 x 16 Cap screw	5
					DF12-2	M3 x 20 Cap screw	3
					DF12-3	M3 x 25 Cap screw	1
					DF12-4	M4 x 30 Cap screw	2
MECHANICAL CASE A							
DF-(1)	DF1-1	Expert stabilizer blade	1		DF12-5	M2 x 6 Pan head machine screw	6
DF-(2)	DF2-1	Expert stabilizer blade	1		DF12-6	M2 x 8 Pan head machine screw	9
DF-(3)	DF3-1	Gimbal seesaw	1		DF12-7	M2 x 14 Pan head machine screw	4
DF-(4)	DF4-1	Main blade root end	2		DF12-8	M2 x 15 Pan head machine screw	1
	DF4-2	Blade holder	2		DF12-10	M3 x 10 Pan head machine screw	1
	DF4-3	Yoke	1		DF12-11	M2 Nut	5
	DF4-4	Bearing 10-15	2		DF12-12	M3 Nut	1
	DF4-5	Bearing 15-20	2		DF12-13	M3U Nut	9
	DF4-6	Thrust CRT6-12	2		DF12-14	M4 U Nut	4
	DF4-7	ø 4 Hardened washer	2		DF12-15	M4 x 4 Set screw	1
	DF4-8	ø 4 Washer	2		DF12-16	M4 x 6 Set screw	5
	DF4-9	Thrust collar	2		DF12-17	ø 2 Flat washer	2
	DF4-10	M4 x 25 Cap screw	2		DF12-18	ø 4 Flat washer	2
DF-(5)	DF5-1	Center hub	1		DF12-19	ø 3 Flat washer	4
					DF12-20	Damper rubber	1
DF-(6)	DF6-1	Radius arm	2		DF12-21	Rod end	10
	DF6-2	Mast block	1		DF12-22	ø 5 Ball	7
	DF6-3	Control arm	1		DF12-23	Pivot bolt A	2
	DF6-4	Pivot arm	1		DF12-24	Pivot arm collar	2
DF-(7)	DF7-1	Main mast	1		DF12-25	Needle pin ø 2 x 11.8	4
					DF12-26	Needle pin ø 3 x 15.8	1
DF-(8)	DF8-1	Swash plate boot	1		DF12-27	Needle pin ø 4 x 29.8	1
				MECHANICAL CASE B			
				DF-(20)	DF20-1	Mission case L	1

DF-3

ment no. of parts	Parts Number	Parts Particulars	Quantity required	ment no. of parts	Parts Number	Parts Particulars	Quantity required	
DF	DF59-6	M2 x 10 Pan head machine screw	1		DF71-18	Tail pitch rod	1	
	DF59-7	M2 Nut	2		DF71-19	Tail blade holder	6	
	DF59-8	M3U Nut	1		DF71-20	Tail blade boss	1	
	DF59-9	M4U Nut	1		DF71-21	Tail blade holder plate	1	
	DF59-10	M2.6 x 6 Tapping screw	14		DF71-22	Tail blade holder cap	1	
	DF59-11	M2.7 x 10 Wood screw	12		DF71-23	Adjust rod M2 x 16	1	
	DF59-12	φ 2 Flat washer	6		DF71-24	Rod end	2	
	DF59-13	φ 2.5 Flat washer	4		DF71-25	φ 5 Ball	2	
	DF59-14	φ 3 Flat washer	4		DF71-26	M2 x 5 SUS pan head machine screw	21	
	DF59-15	φ 4 Flat washer	2		DF71-27	M2 x 8 Pan head machine screw	1	
	DF-(60)	DF60-1	Adjust rod M2 x 160		3	DF71-28	M2 x 18 Pan head machine screw	4
		DF60-2	Adjust rod M2 x 290		3	DF71-29	M2 Nut	8
		DF60-3	φ 1.2 x 200 Rod		1	DF71-30	M3U Nut	1
	DF-(61)	DF61-1	Adjust joint A		3	DF71-31	Needle pin φ 2 x 8.8	1
	DF-(62)	DF62-1	Adjust joint B		4			
BODY KIT				MECHANICAL CASE				
DF-(70)	DF70-1	Body case	1	DF-(80)	DF80-1	Instruction manual		
	DF70-2	Sticking paper	1		DF80-2	Skid foot	2	
	DF70-3	Body FRP	1 set		DF80-3	Skid pipe	2	
	DF70-4	Body frame	1 set		DF80-4	New skid band	4	
	DF70-5	Horizontal tail blade	1		DF80-5	Damper rubber mounting plate	4	
	DF70-6	Balsa material	1		DF80-6	Damper rubber mounting band	4	
	DF70-7	Drawing	1		DF80-7	Skid pipe cap	4	
	DF70-8	Transcribing mark	1		DF80-8	Bushing rubber	4	
	DF70-9	Wire net	1		DF80-9	M3 x 6 Cap screw	8	
	DF70-10	Windshield	1		DF80-10	M2 x 14 Pan head machine screw	8	
	DF70-11	Cooling cover	1		DF80-11	M2 x 5 Tapping screw	4	
	DF70-12	Wire set member	1		DF80-12	M2 Nut	8	
	DF70-13	Fuel tank band	1		DF80-13	φ 5.1 Rod end	2	
	DF70-14	Antenna A	2		DF80-14	Accessory pipe	1	
	DF70-15	Fuel tank 400cc.	1		DF80-15	Mechanical case	1	
	DF70-16	Tail drive shaft	1		DF80-16	60 Gazelle Seal	3	
	DF70-17	Rudder control wire	1					
	DF70-18	φ 3 x 1100 BS Pipe	1					
	DF70-19	φ 3 x 800 BS Pipe	1					
	DF70-20	Rudder control pipe	1					
	DF70-21	Main blade	2					

	DF70-22	1mm thick veneer	1				
	DF70-23	Dummy engine	1 set				
	(TAIL TURBINE SET)						
DF-(71)	DF71-1	Tail turbine case	1				
	DF71-2	Turbine blade	6				
	DF71-3	Needle pin ϕ 1.5 x 11.8	6				
	DF71-4	ϕ 1.7 Flat washer	8				
	DF71-5	Turbine blade bushing	6				
	DF-71-6	Duct A	1				
	DF71-7	Duct B	1				
	DF71-8	Duct ring	1				
	DF71-9	1st miter gear (Right)					
	DF71-10	Tail 1st shaft collar	1				
	DF71-11	Bearing 685 ZZ	1				
	DF71-12	Bearing 685 OP	3				
	DF71-13	Tail 2nd shaft	1				
	DF71-14	2nd miter gear (Left)	1				
	DF71-15	Joint B	1				
	DF71-16	Tail pitch ring	1				
	DF71-17	Bearing 692 OP	2				

ARRANGEMENT VIEW OF PARTS IN MECHANICAL CASES

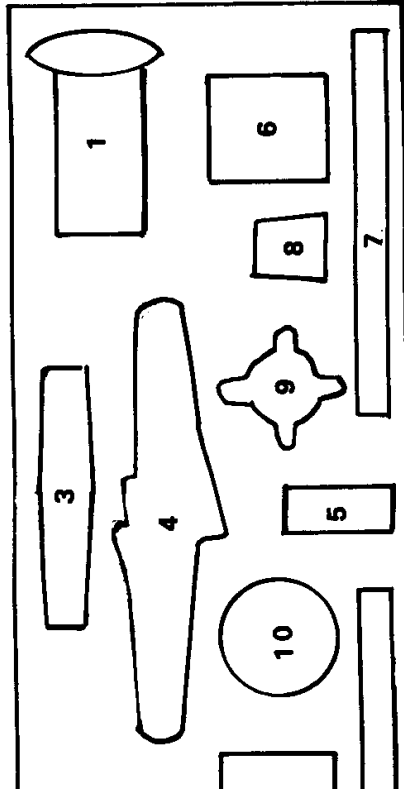

Mecha. A

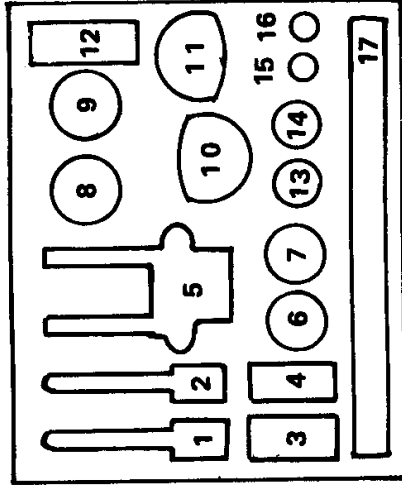

Mecha. A-B

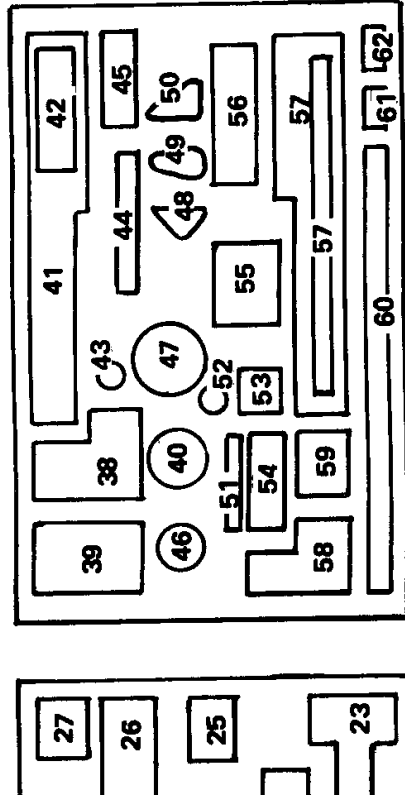

Mecha. C1

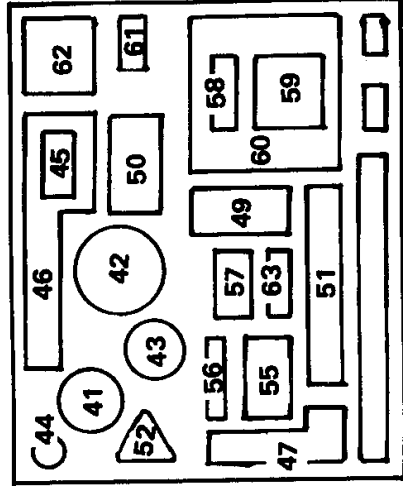

Mecha. C2 (for LAMA)

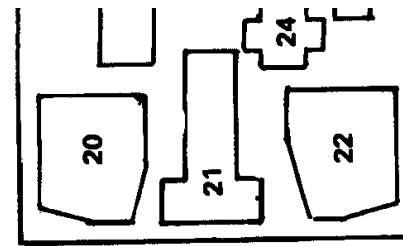
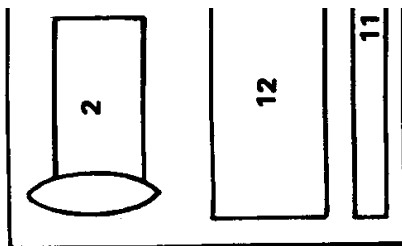

Mecha.

ヒロボーR/C S A - 341Gガゼルをお買上げいただき誠にありがとうございました。キットの内容及び数量については、十分な検査を致しておりますが、念のため各部品小袋内の数量確認を行なって下さい。
万一不足のあった場合はお手数ですがそのままお買上店又は弊社まで御連絡下さい。

Thank you very much for your purchase of Hirobo R/C model helicopter "Gazelle". Through the quality and quantity of the model kits have been severely checked before shipment, please re-check the quantity of the components and parts contained in each small sack in order to make doubly sure. If you should find anything wrong, please be free to contact the shop where you have purchased or directly Hirobo Industrial Co., Ltd.

検査 Inspection



ヒロボ一株式会社

広島県府中市府川町234 〒726 ☎(0847)45-3470

HIROBO INDUSTRIAL CO., LTD.

234, Fukawa-cho, Fuchu-shi, 726, Hiroshima, Japan.

Cable:Hirobo Fuchuhiroshima Telex: 6457-77 Hirobo