

INFUSION 600N Pro

***** Instruction Manual



Nigel Brown
DESIGNED BY
NIGEL BROWN



ENDLESS PURSUIT OF PERFECTION

Welcome to the TSA family and congratulations on your new purchase. Please read this instruction manual carefully to ensure you understand every step of the build process. Most of all happy building and we look forward to seeing you around the world at many events.

Contents

- ★ 1~2. Introduction
- ★ 3. Safety instructions prior to assembly
- ★ 4~5. Tools required for assembly
- ★ 6~31. Parts assembly
- ★ 32. Blade tracking adjustment
- ★ 33~34. Operation mode
- ★ 35. Flying notes
- ★ 36~42. Parts package list



***** **INFUSION 6000**
Pro



While in flight

- 1: Beginners should obtain safety and technical guidance from an experienced individual, since learning alone to operate this machine is potentially dangerous.
- 2: Choose a safe flying area that is free of obstruction and people.
- 3: Do not fly in a potentially dangerous environment.
- 4: Do not operate while standing on tilted ground to avoid loss of balance.
- 5: Do not insert hands and objects in rotating parts.
- 6: Keep a safe distance from the unit and be sure to operate the unit within the limits of your ability. Failure to operate this unit properly may result in serious harm such as physical injury, damages to property, and even death.
- 7: Enjoy flying while observing safety rules and regulations. Fatigue brought upon by continuous operation may result in impaired judgment that may lead to accidents.
- 8: Inquiries regarding repairs and services should only be made to TSA authorized dealers or TSA technical support department. Individual lacking proper training or knowledge necessary for repair may not only impair the unit's performance, but also increases the risk of accidents or injury. The engine must be turned off before performing any repairs or adjustments. Repair damaged parts before storage using only TSA manufactured parts. When storing or transporting the units, secure the unit carefully to avoid fuel loss, damage, or injury.



Fuel for engine

- 1: Only use glow fuel for glow model engines.
Glow fuel is highly flammable and should be handled with care.
- 2: Before refueling, the engine should be turned off.
- 3: Do not refuel near a naked flame. Do not smoke while refueling. Avoid spillage and be sure to always completely wipe down any spilled fuel. Since fuel vapor and exhausted gas from the unit's operation are hazardous to health, this product is only intended to be used in an outdoor environment.
- 4: The fuel is hazardous. Do not consume and avoid getting fuel in the eyes. If an accident or swallowed occurs, obtain professional medical advice/treatment immediately.
- 5: Fasten the cap on the fuel bottle tightly and store in a cool shaded place. Keep the fuel out of reach of children. The ideal storage temperature should be around 10°C.



Pre-flight inspection

- 1: Check that tools used for assembly and maintenance has been put away.
- 2: Check that there are no loose screws and parts.
- 3: Check that the rotor blades are not damaged or cracked, especially in the vicinity of the blade holder.
- 4: Check the condition of the glow plugs and fuel, old glow plugs and fuel may not only cause difficulties to start the engine, but also the possibility of stalling and crashing in mid-flight.
- 5: Check that electronic equipment and servos operates smoothly.
- 6: Check that the position of the transmitter's throttle stick and engine carburetor are at their low position.
- 7: Check that the receiver receives signals properly.
- 8: Check and ensure that all necessary parts are sufficiently lubricated.
- 9: Check radio is assigned to the correct mode.



In-flight safety inspection

- 1: When starting the engine, be sure to hold the rotor head firmly so the rotor head does not rotate.
- 2: Since the engine and muffler is heated from the operation and remains extremely hot immediately after startup or shutdown, take extra precaution to prevent burns.
- 3: When taking off, the unit should be positioned at least 10 meters away from the operator. Be sure to check for people and dangerous object in the surrounding area before takeoff.
- 4: Adjust the blade tracking right before takeoff.
- 5: Land the unit immediately if abnormal noise or vibration is observed. Then stop the engine and perform complete check for cause of problem.
- 6: Be responsible when operating this unit, as reckless or improper behavior may cause accidents or injury to self or others. Observe all safety rules and regulation while enjoy operating this unit safely and responsibly.



After-flight safety inspection

- 1: Immediately inspect parts after every flight. Be sure to replace, retighten any missing or loose screws and replace any damaged parts.
- 2: Wipe down grease, oil, dirt and dust with a clean cloth.
- 3: If the unit is to be stored out of operation for a long period of time, completely drain remaining fuel from the fuel tank and carburetor.
- 4: Store the unit in an area free of direct sunlight, or other areas that may result in rise in temperature (e.g., car). Instead, store in a shaded and ventilated area, and keep out of reach of children.



Warning

- 1: To reduce the risk of accidents and injuries, do not use parts other than those found in this manual or TSA catalog. TSA will not be responsible for problems caused by using non-genuine TSA parts.
- 2: If the rotor blades should strike the ground during flight, there may be tiny cracks or loosening in various places even though damages may not be clearly visible to naked eyes. If damage to the rotor blade is not fixed before flight, cracks and loosening may increase during flight that would lead to severe consequences. The rotor head may disassemble from the blade holder, which spins at a speed of 1200/2000 rpm, and may fly off from the blade holder. If in doubt regarding the condition of any part, replace the part immediately using only genuine TSA parts.
- 3: TSA will not be held responsible for damages or crash as a result from any loose screws and/or improper maintenance.
- 4: Radio wave transmitting distance is approximately one kilometer or more, therefore operator must check no other operators in the surrounding vicinity are using the same radio frequency.
- 5: This remote control model is not a toy, rather a precise machine. Proper assembly and adjustments must be made in order to avoid the risk of injuries or accidents. Operator should operate this unit safely and properly. Failure to operate this unit properly may result in serious harm such as physical injury, damages to properties, and even death. The operator is responsible for all damages, because TSA cannot control how the unit was assembled and used.
- 6: Recommended 14+ years .



Caution

Please abide by regulations in your county while enjoying the pleasure brought to you by the  600N series.



Preassembly precautions

1. Before assembly, read the instruction manual thoroughly and familiarize yourself with the unit's structure and assembly procedures. Failure to assemble the unit properly may not only impair performance but also increases the risk of danger.
2. Before assembly, check description and quantity of parts. In the event of missing or defective items, contact retailer of original purchase where authorized distributor or TSA support department can be located.

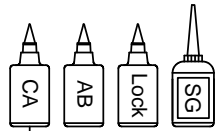

Self-furnished

CA=Cynoacrylate adhesive
 AB=5 minute epoxy / A=3 : B=1
 Lock=Thread lock
 SG=Silicone grease

Diagram for applying thread lock

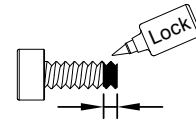

Glue width :1.5mm

3. Apply lubricant and retainers on locations as indicated .
4. In the instruction manual, refer to the left hand column to check the type and quantity of parts.

Swashplate Assembly

T-016-00

Parts order number

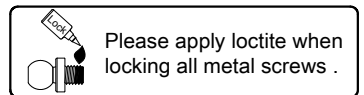

Part name and quantity in this diagram is to 1:1 ratio

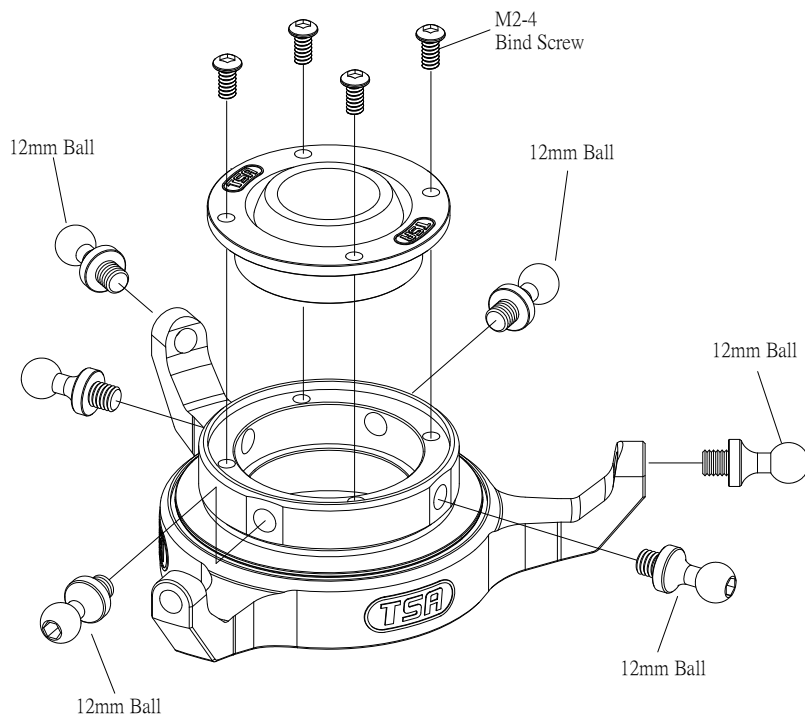
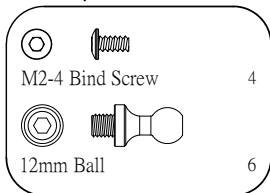

Assembly Tip

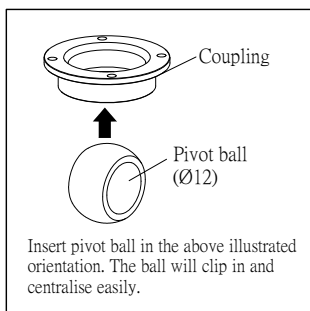

TOOLS REQUIRED FOR ASSEMBLY

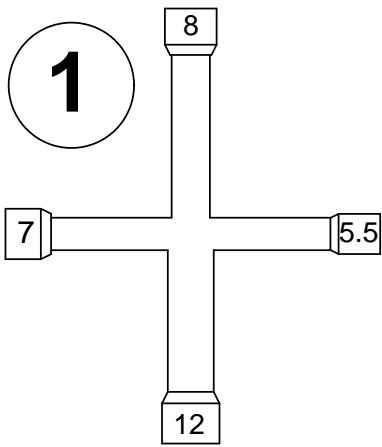

Cross wrench
(5.5~12)



Metric ruler
(Over 30cm)

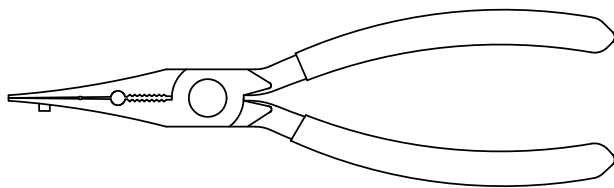

Universal ball link plier

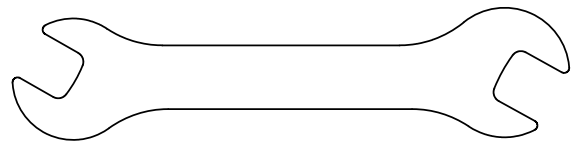

Spanner
(6mm/8mm/12mm/21mm)

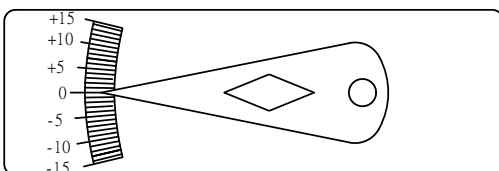

Pitch gauge

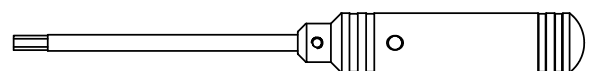

(Allen head) Screw drivers
(1.5mm/2mm/2.5mm/3mm/3.5mm/
4mm/5mm)

EQUIPMENT REQUIRED FOR OPERATION

1

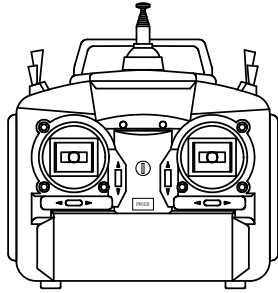

Transmitter(7 channels)

Receiver



On/off switch

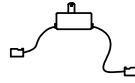

Receiver battery

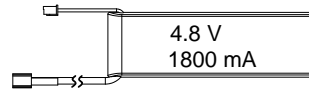

3 Axis gyro system

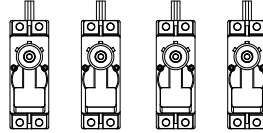
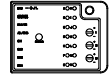

Servos



Rudder servo

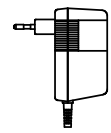

Charger

2

50 size helicopter engine

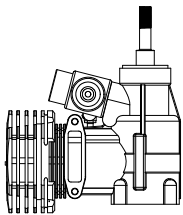

3

50 size helicopter muffler

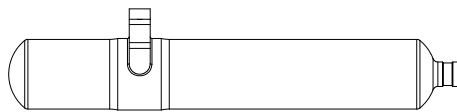

4

Starter

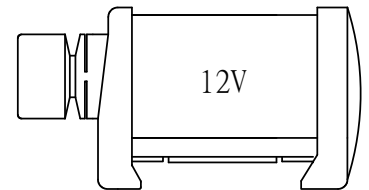

5

Starter shaft



6

12V Battery

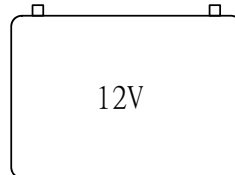

7

Remote glow plug adapter



8

Fuel filter

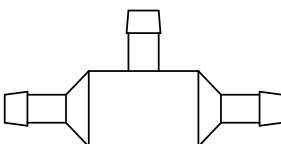

9

Nitro fuel for model helicopter (10~30%)

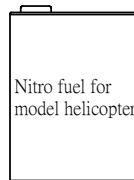

10

Fuel pump

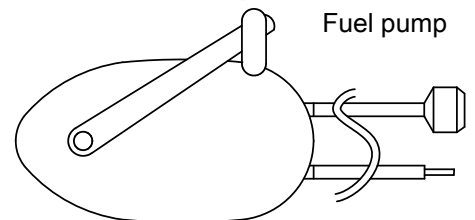

1

Main Frame Assembly-1

T-001-01

T-007-00

T-003-00

T-005-00

 Please apply loctite when locking all metal screws .

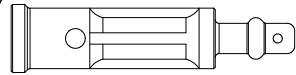

37.5mm Canopy rear support 1

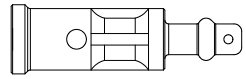

30.5mm Canopy front support 1



M2-6 Bind Screw 2

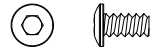

M3-6 Bind screw 4



M3-8 PH screw 2

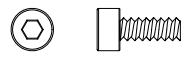

M3-8 Cap screw 2

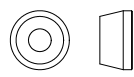

Custom Washer 2

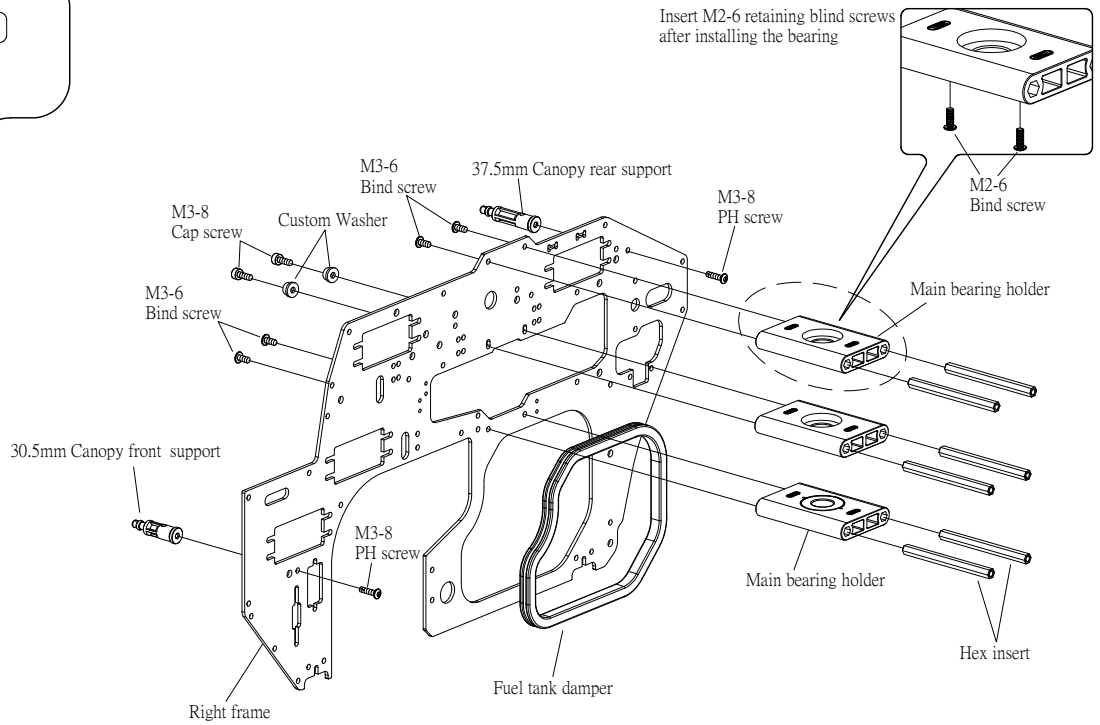

2

Main Frame Assembly-2

T-001-01

T-009-04

T-002-00

T-022-00

T-005-00

T-031-00

 Please apply loctite when locking all metal screws .

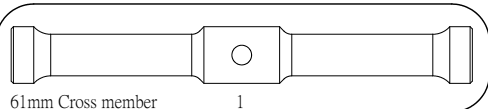

61mm Cross member 1

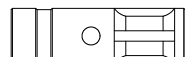

23mm Servo support 2



Ø5xØ10x4 Flange Brg 1

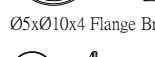

M3-6 Bind screw 1



M3-8 PH screw 7



M3-12 PH screw 1

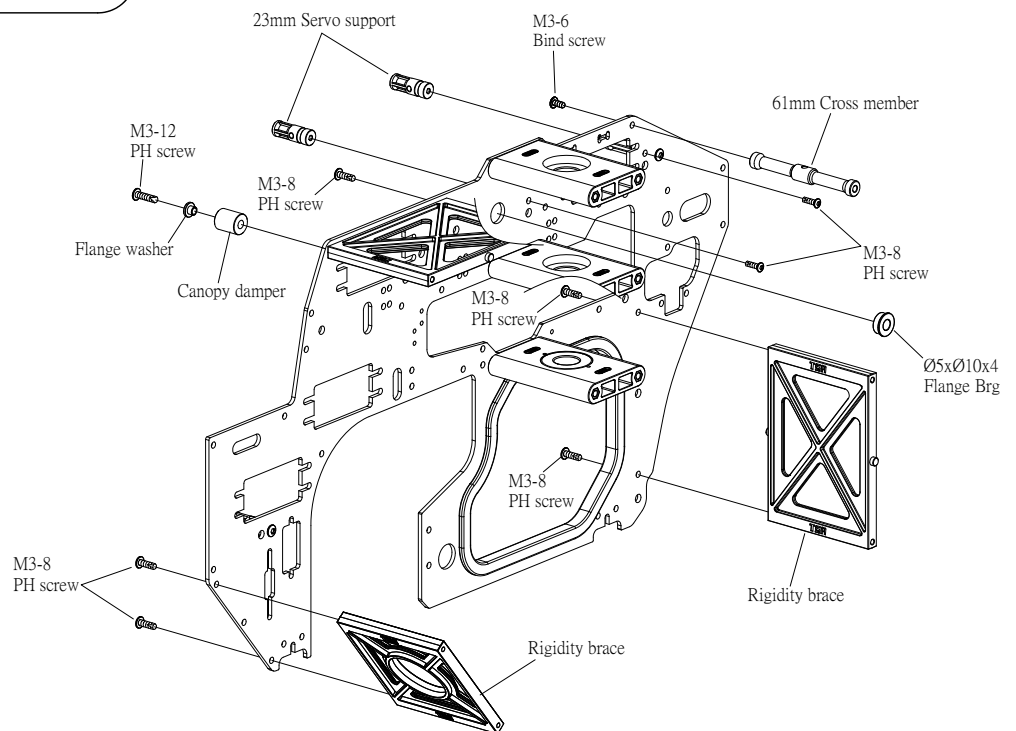

3

Main Frame Assembly-3



T-001-00

T-022-00

T-003-00

T-005-00

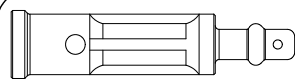
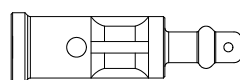
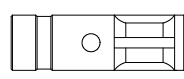
 Please apply loctite when locking all metal screws .

-  37.5mm Canopy rear support 1
-  30.5mm Canopy front support 1
-  23mm Servo support 2
-  M3-8 PH screw 4
-  Ø5xØ10x4 Flange Brg 1

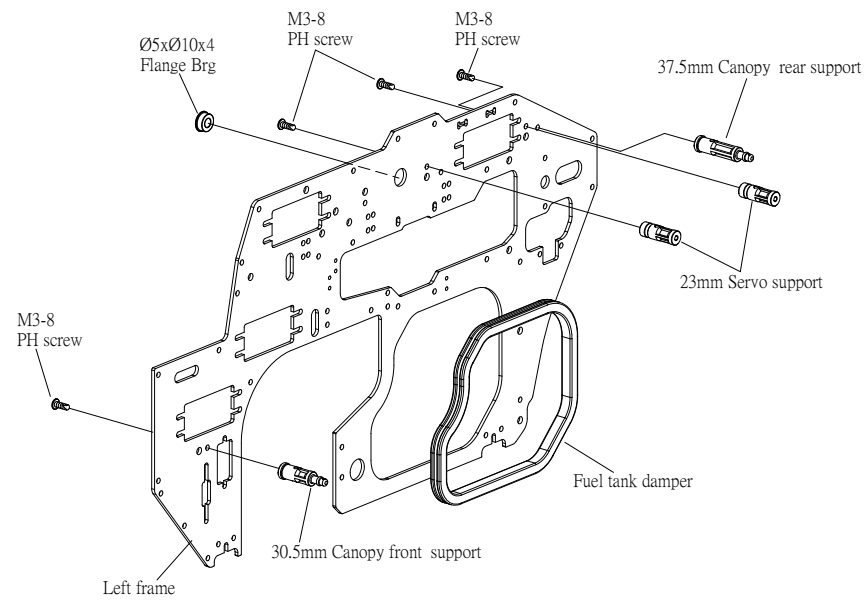





4

Tail Drive Gear Assembly

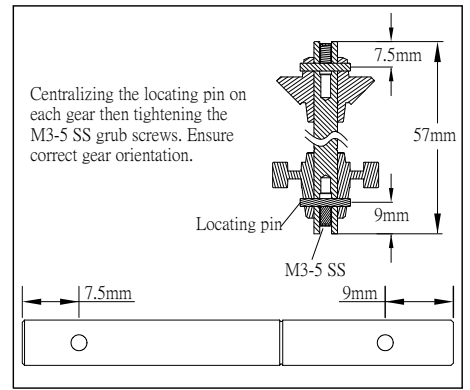
T-019-00

 Please apply loctite when locking all metal screws .

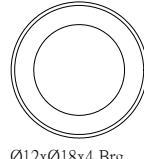
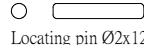
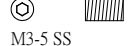

-  Ø6xØ13x5 Brg 2
-  Ø12xØ18x4 Brg 2
-  Locating pin Ø2x12 2
-  M3-5 SS 2
-  M3-8 Bind screw 1

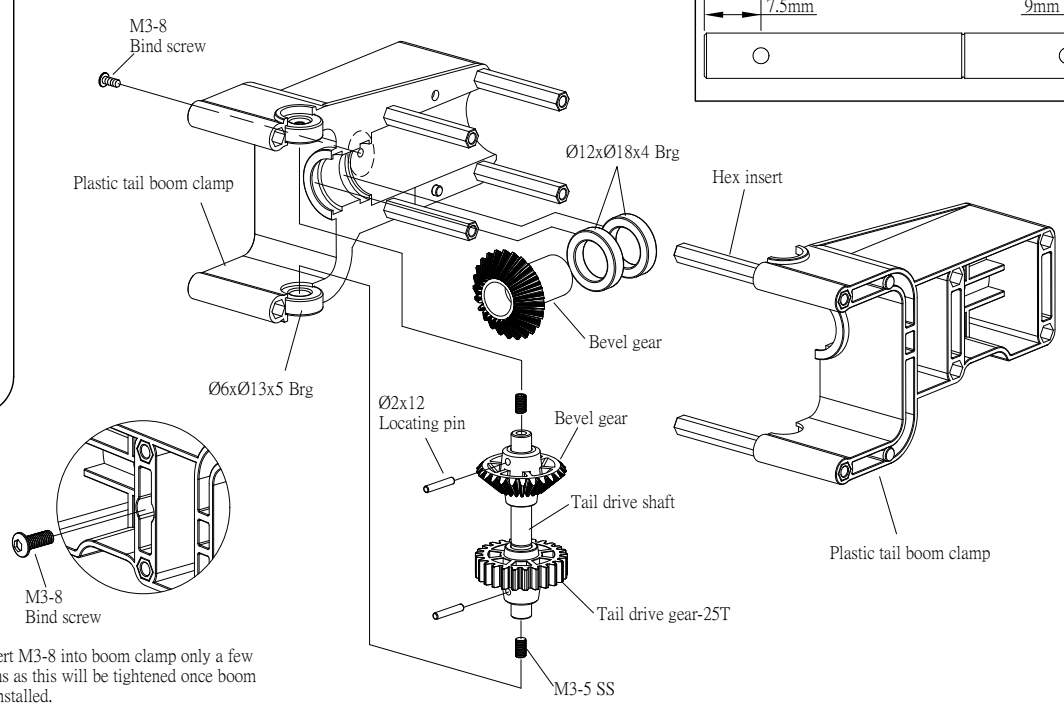

Insert M3-8 into boom clamp only a few turns as this will be tightened once boom is installed.

7

Main Frame Assembly-5

T-002-00













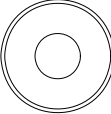

T-010-00

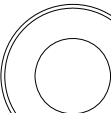
T-006-00

T-016-00

T-007-00

 Please apply loctite when locking all metal screws.

		1			1
		4			2
		8			
		2			
		6			

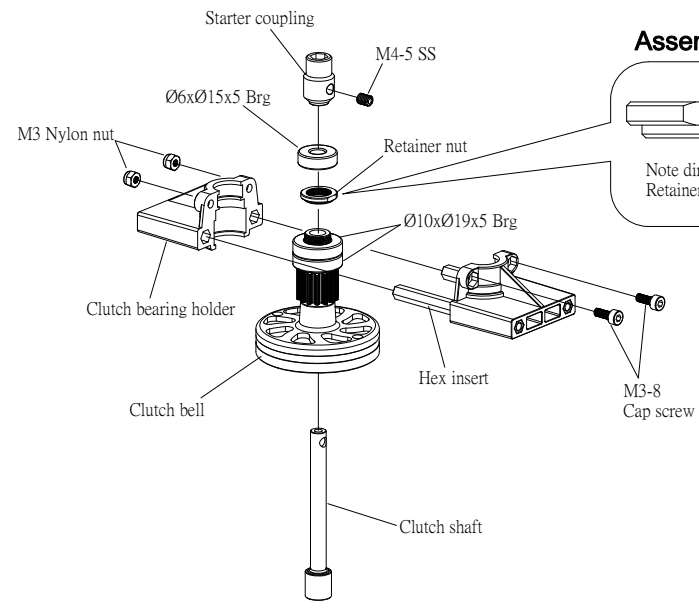
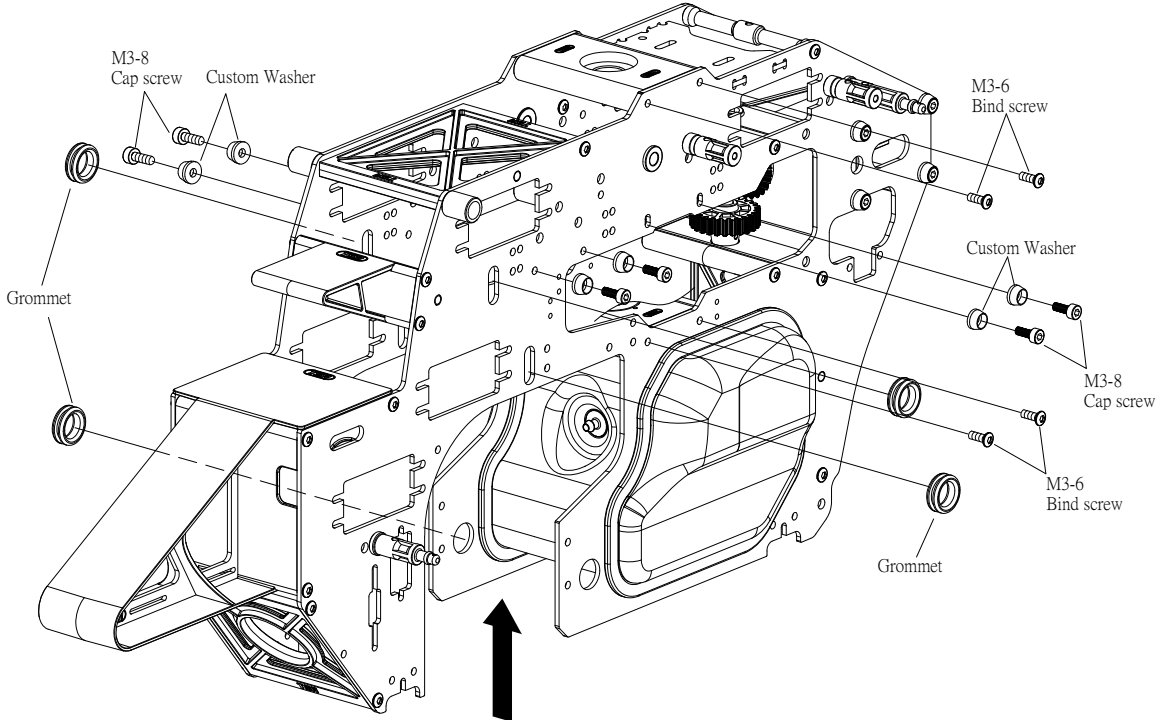

Assembly Tip

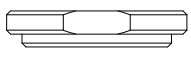





Note direction of the Retainer nut!

8

RPM Sensor Assembly

Two means of induced magnet RPM Sensor assembly are provided!

 Please apply loctite when locking all metal screws .

		2
		2
		2

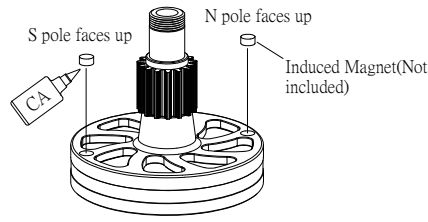

Suitable for both TSA and Futaba RPM Sensor assembly.

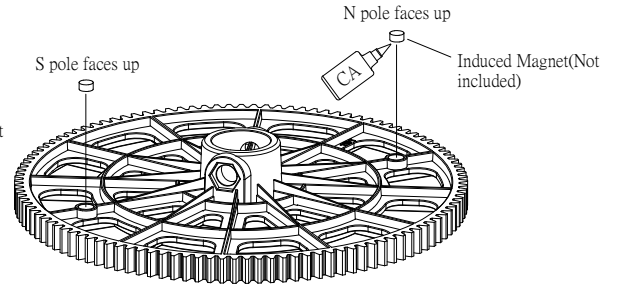

Only for TSA RPM Sensor assembly.

TSA RPM Sensor assembly means 1: (only for right main frame assembly)

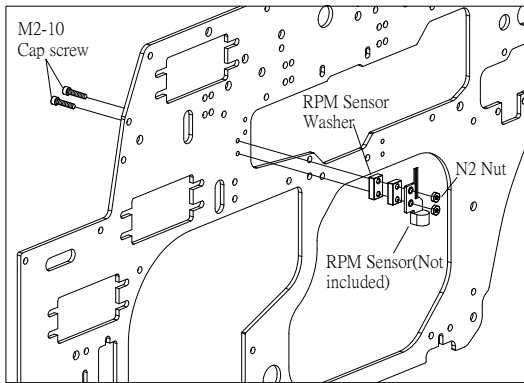
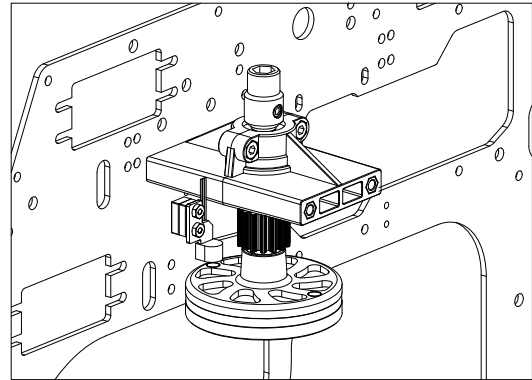

Diagram :



TSA RPM Sensor assembly means 2: (only for left main frame assembly)

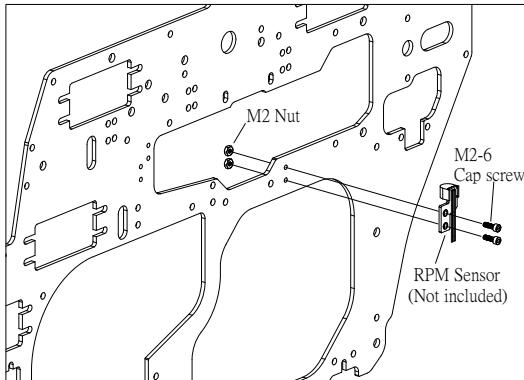
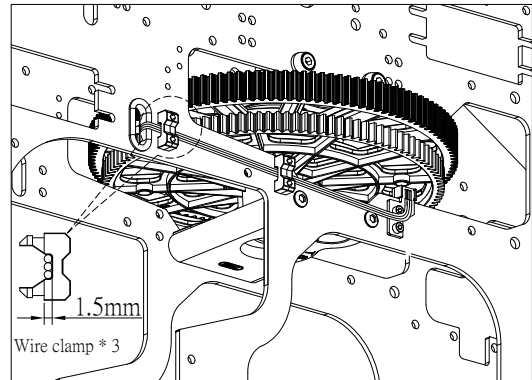

Diagram :



Futaba RPM Sensor assembly means : (for both right and left main frame assembly)

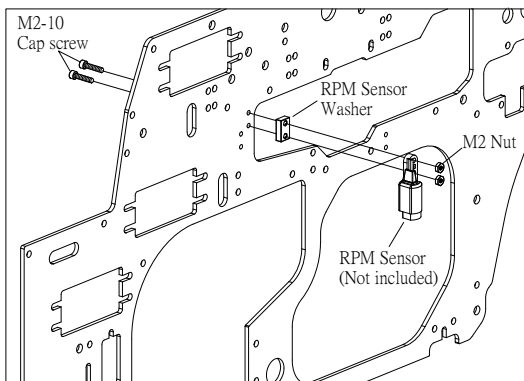
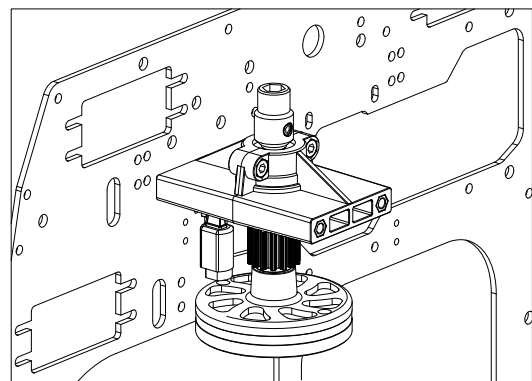



Diagram :







9

Engine Assembly

T-010-00
T-014-00

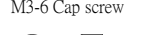
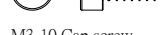
 Please apply loctite when locking all metal screws .

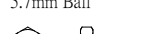

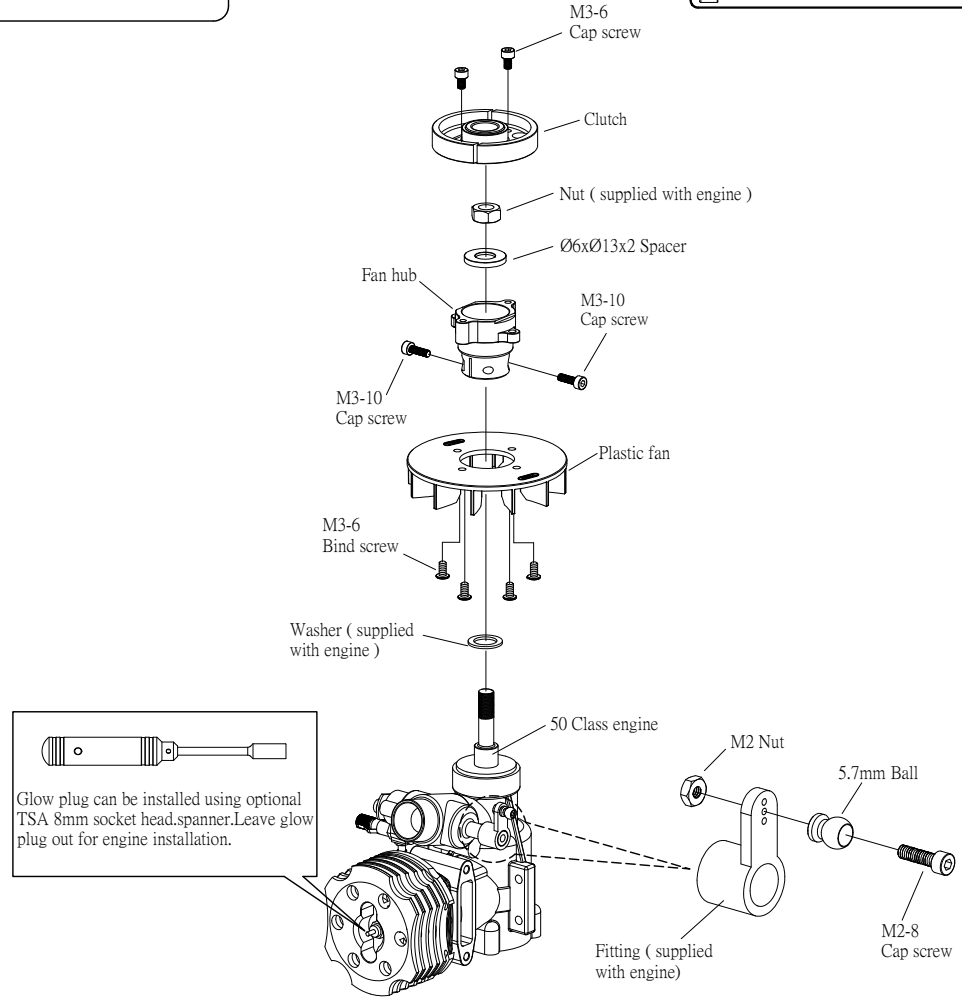
-  1
-  2
-  2
-  4
-  1
-  1
-  1



10

Landing Gear Assembly-1

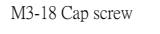
T-012-00
T-013-00

-  4
-  4
-  4
-  4

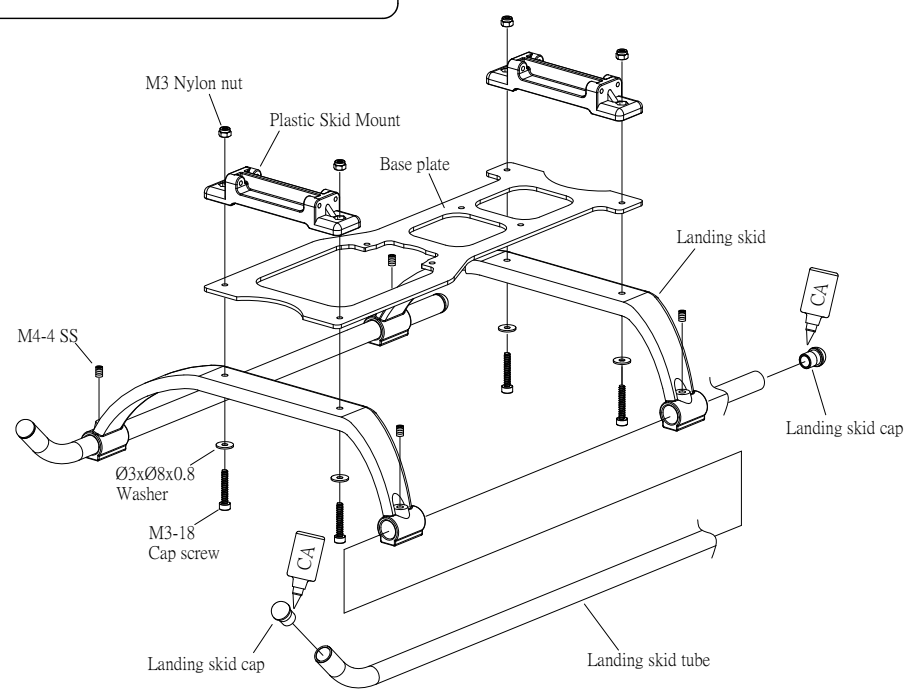







11

Landing Gear Assembly-2

T-012-00

T-014-00

 Please apply loctite when locking all metal screws .

-   6
-   8
-   6

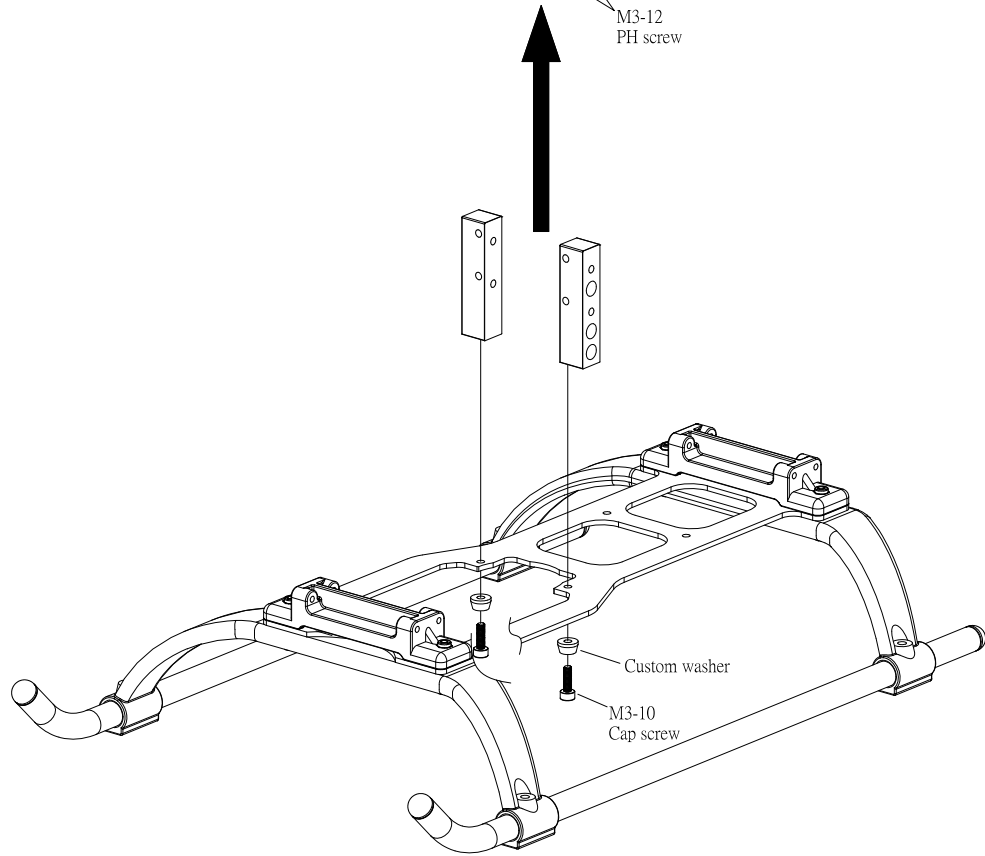
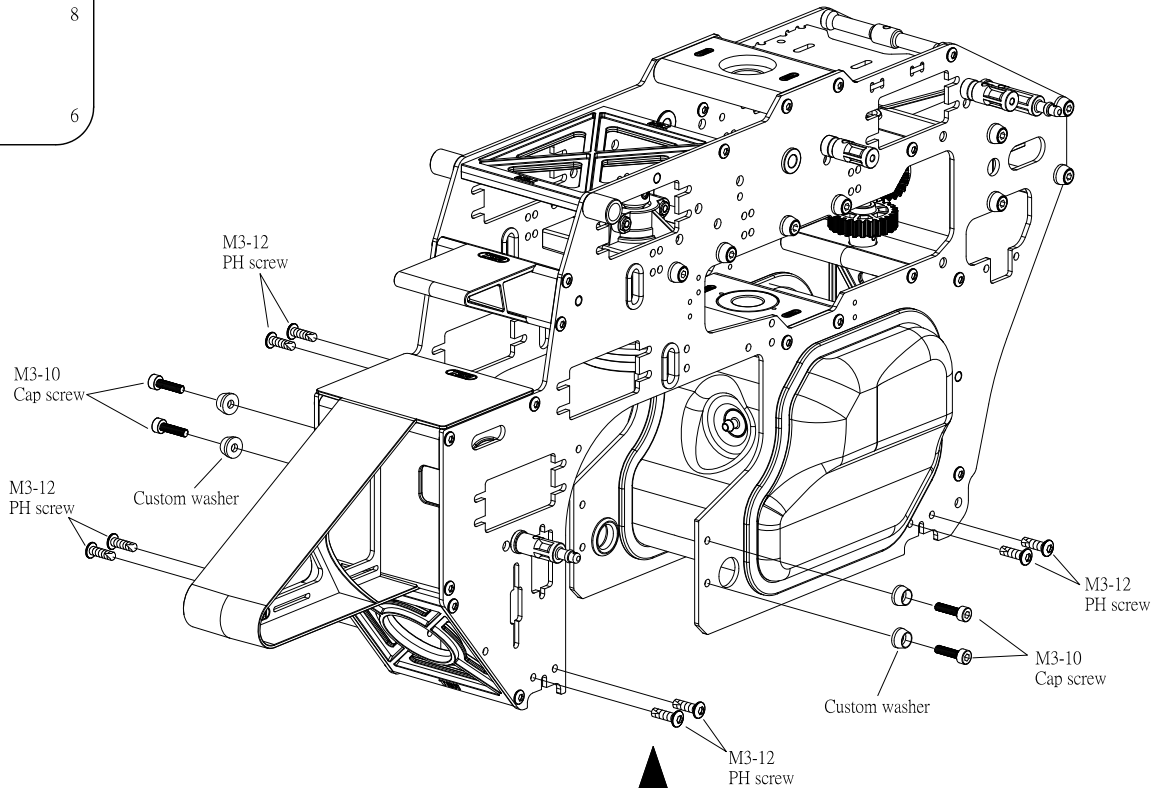



















12

Elevator Lever Assembly

T-011-00

 Please apply loctite when locking all metal screws .

- | | | |
|---|---|---|
|  |  | 2 |
|  |  | 4 |
|  |  | 4 |
|  |  | 1 |
|  |  | 1 |
|  |  | 2 |
|  |  | 2 |
|  |  | 4 |
|  |  | 4 |

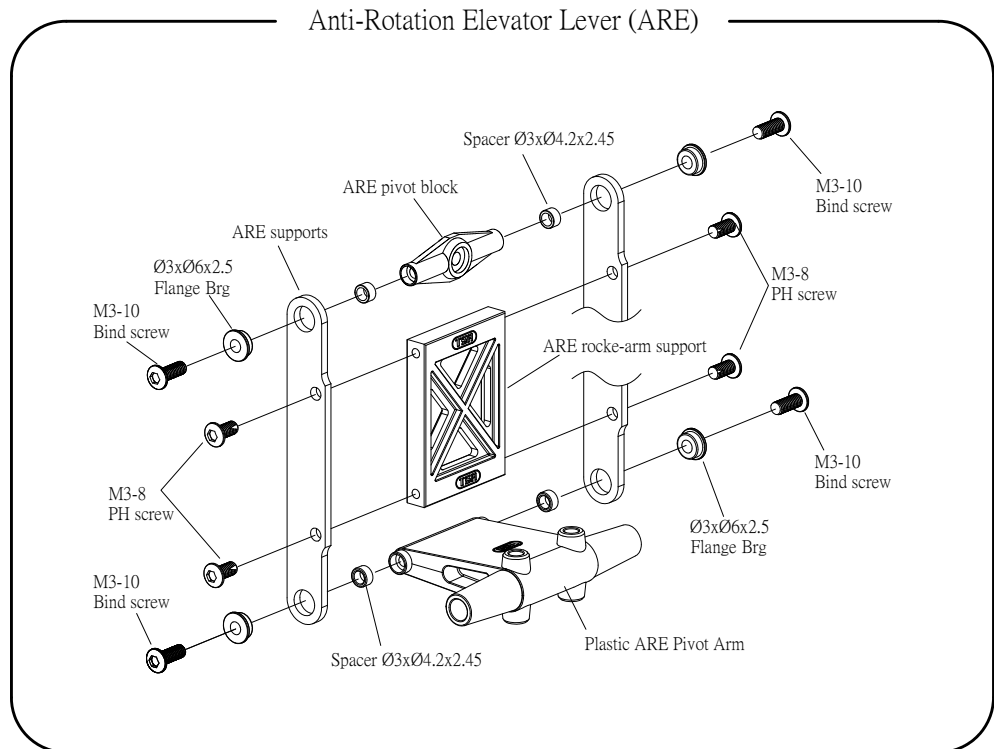
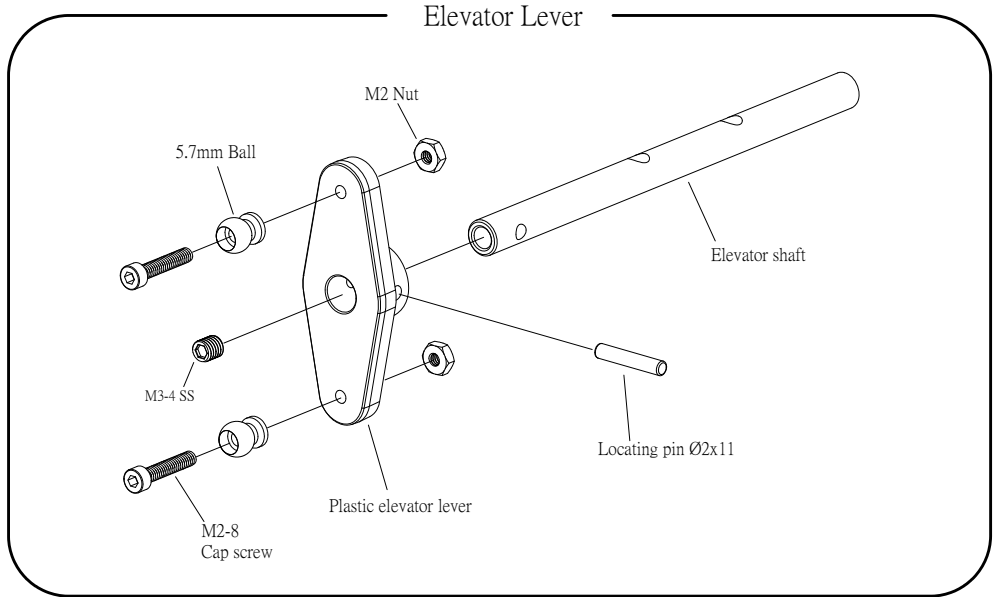







13

Servo Assembly

T-011-00

T-024-00

 Please apply loctite when locking all metal screws .

-   22
-   1
-   2

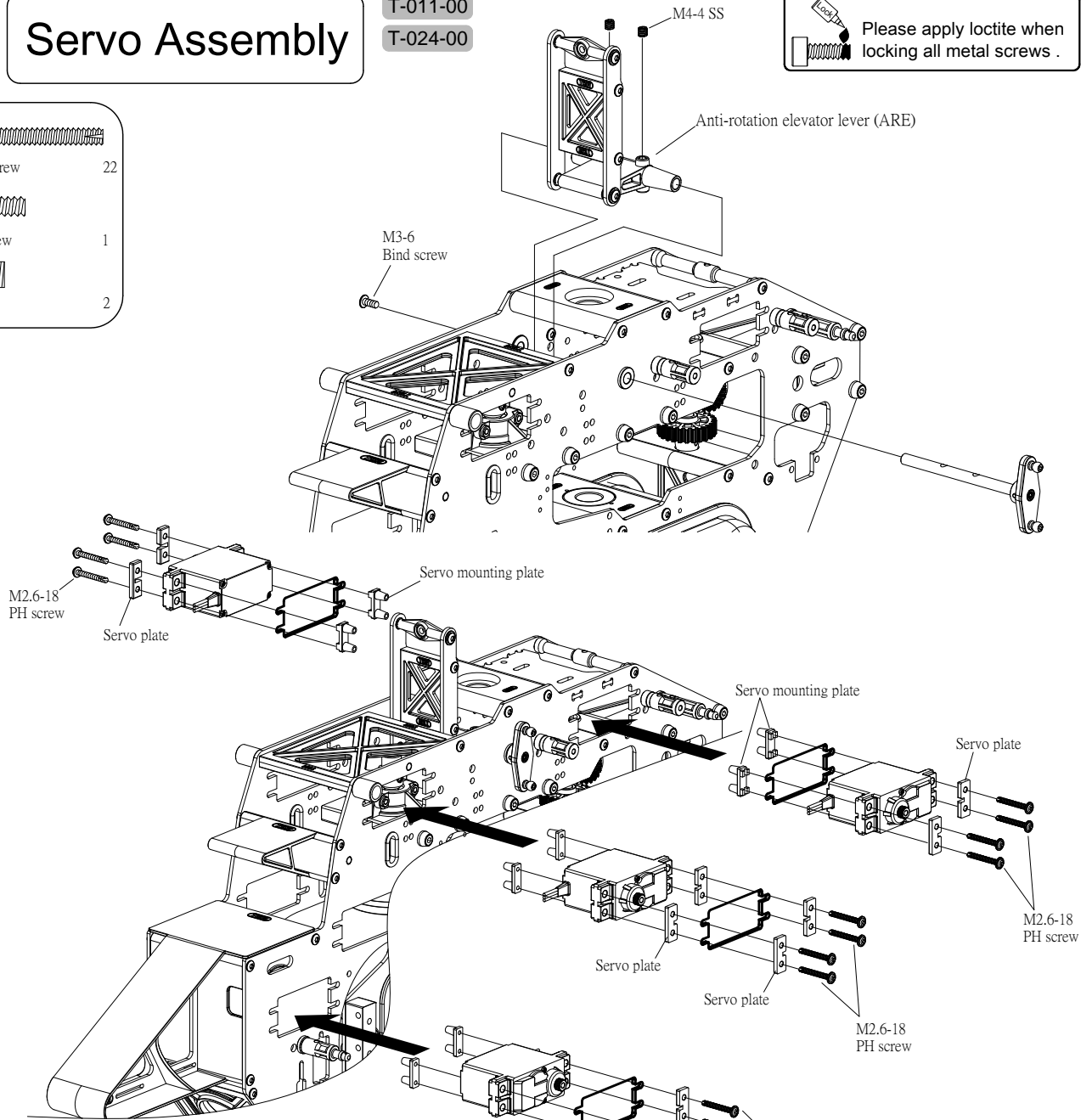

Assembly Tip

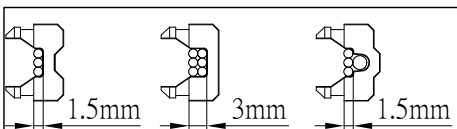
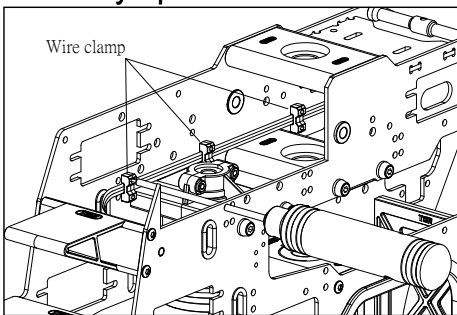

Use corresponding wire clamp according to the connecting means as shown in the diagram.

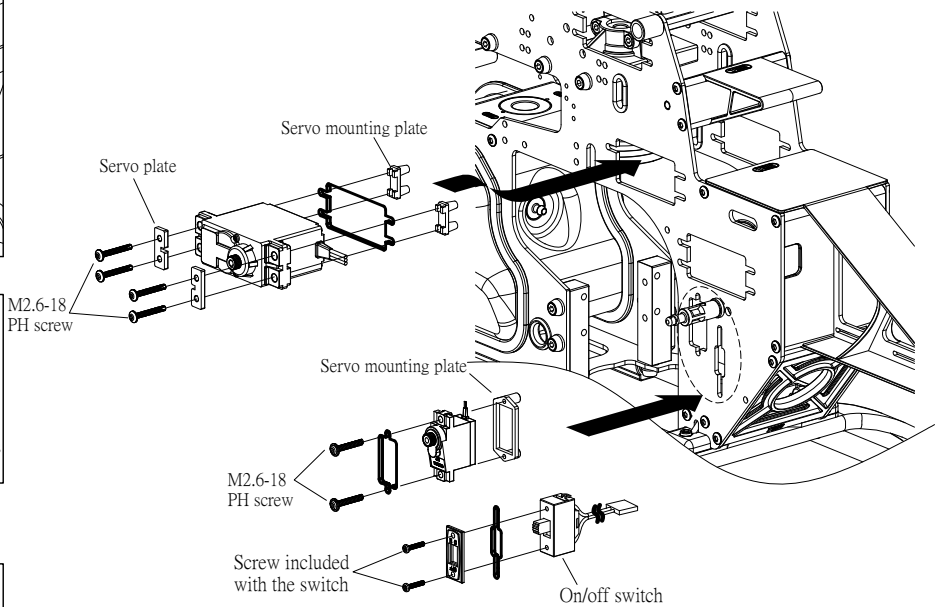

Caution

All servo wires should be segregated to avoid being cut by the the main frame.

14









Servo Support Assembly

T-020-00

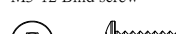
T-022-00

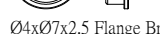
T-025-00

 Please apply loctite when locking all metal screws .

-  M2-8 Cap screw 2
-  M2.6-12 Bind screw 2
-  M3-12 Bind screw 2
-  M3-8 PH screw 4
-  Ø4xØ7x2.5 Flange Brg 2
-  Servo support guide Ø3xØ6x7 2
-  5.7mm Ball 2
-  13mm Ball 2
-  M2 Nut 2
-  Ball link-long 4

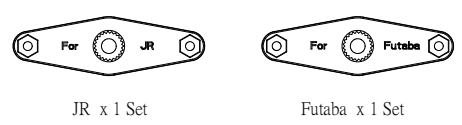
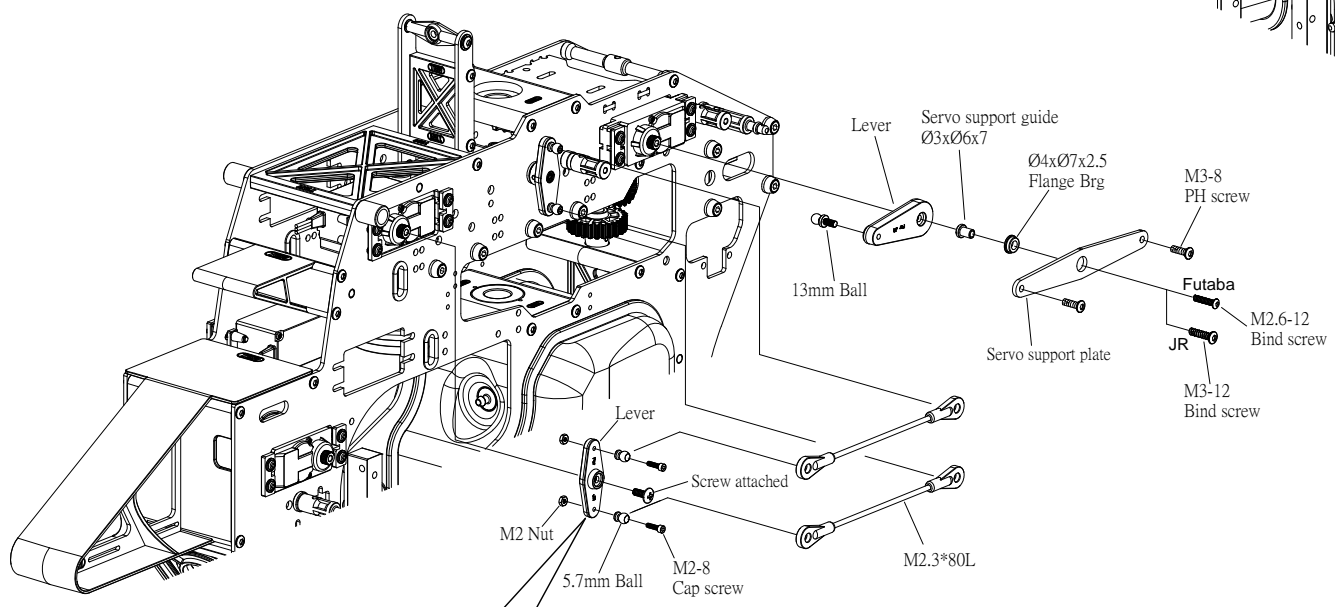
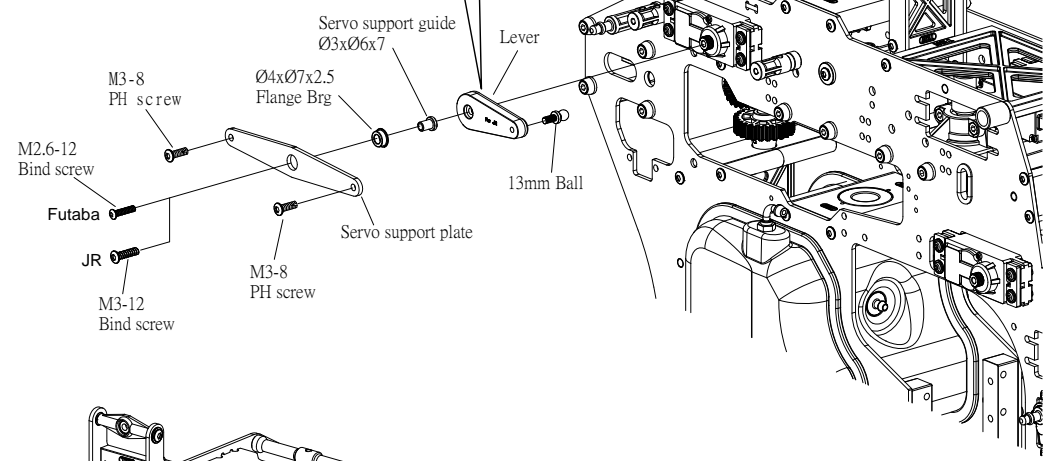
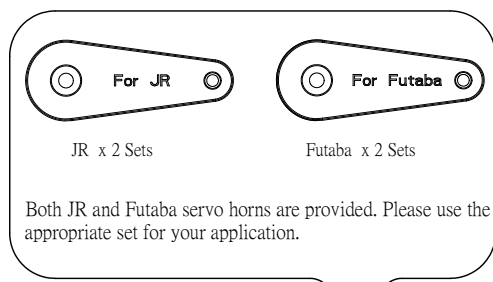

Both JR and Futaba servo horns are provided. Please use the appropriate set for your application.

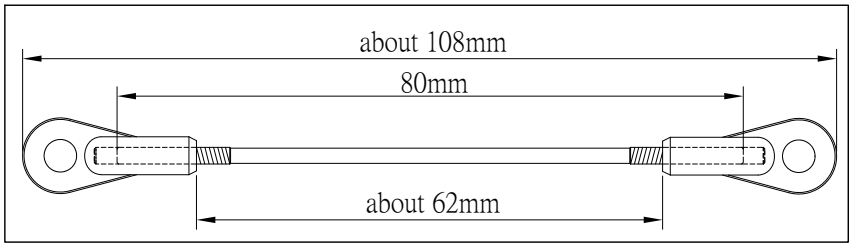





15

Fan and Engine Assembly

T-010-00

T-014-00

 Please apply loctite when locking all metal screws .

-   M3-6 Bind Screw 4
-   M3-15 Cap screw 4

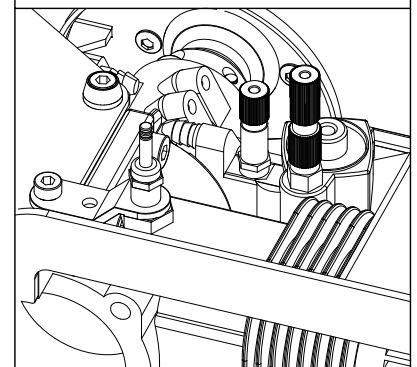
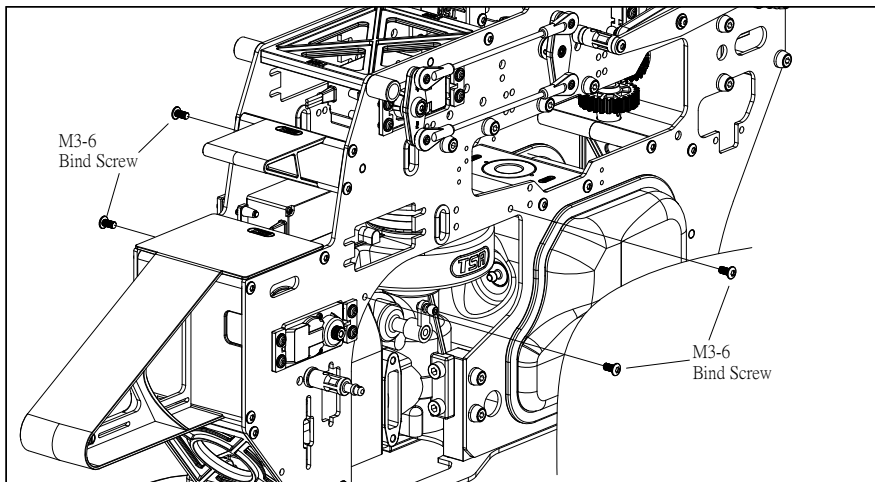
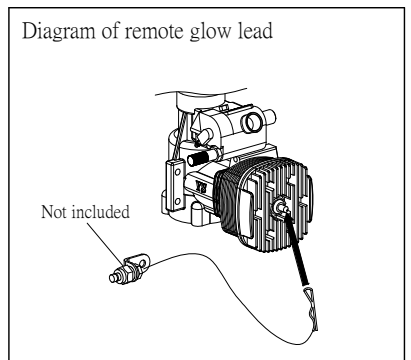
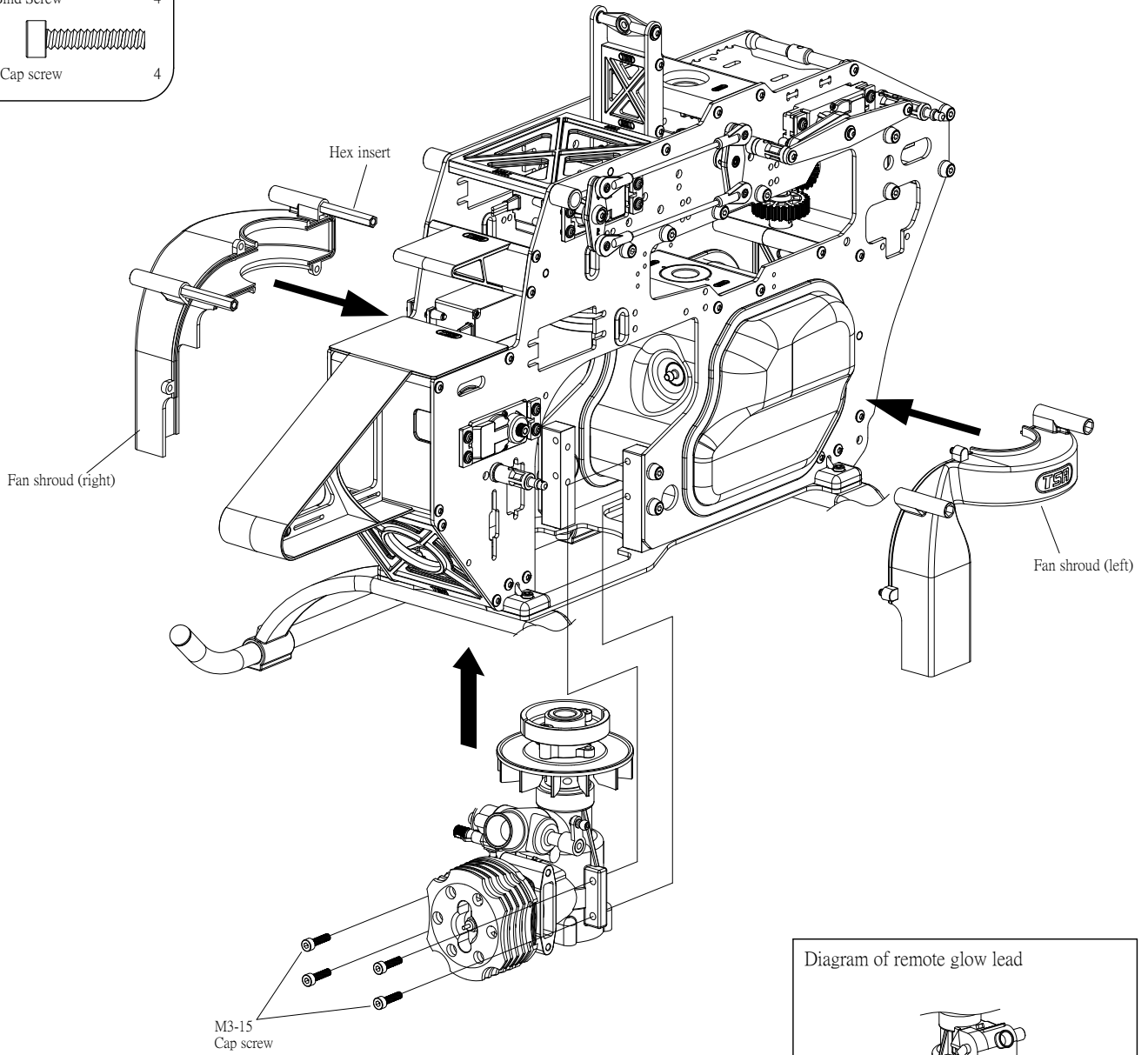

16

Main Gear Assembly

T-015-00

 Please apply loctite when locking all metal screws .

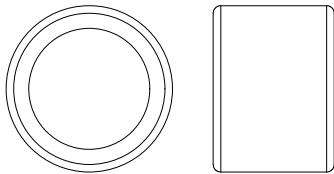

Ø16xØ22x16 One way bearing 1

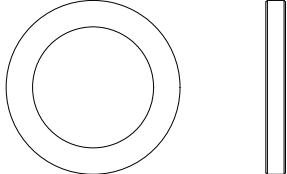

Spacer Ø16xØ23x2.6 2

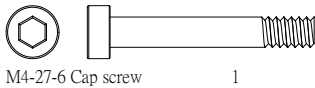

M4-27-6 Cap screw 1

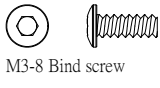

M3-8 Bind screw 6



M4 Nylon nut 1

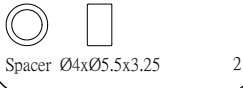

Spacer Ø4xØ5.5x3.25 2

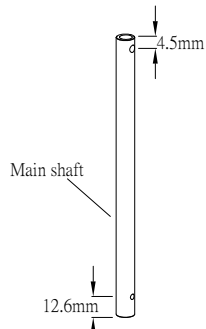

Main shaft

12.6mm

4.5mm

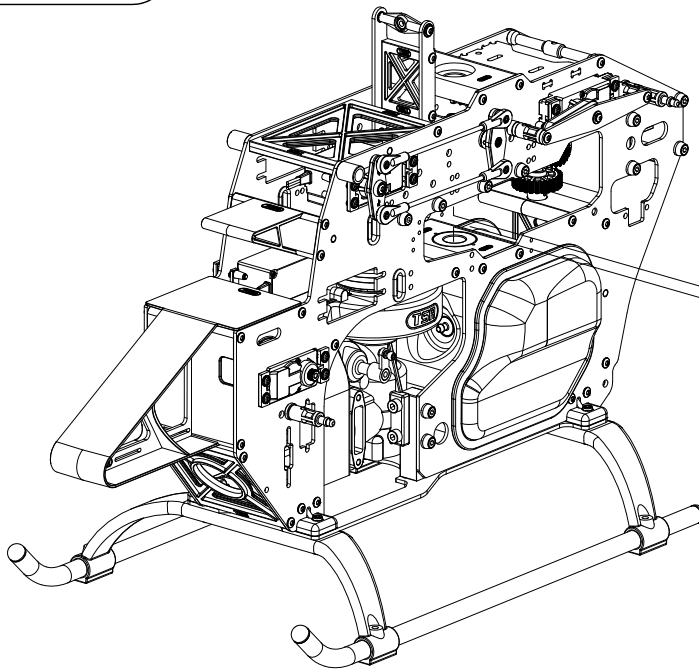

Caution

Only use long shank M4 mounting screw!

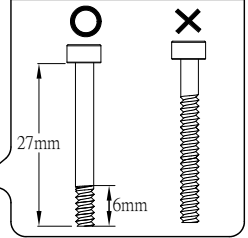

M4 Nylon nut

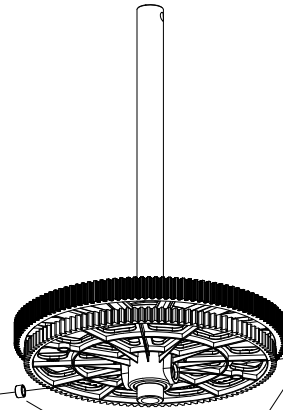

M4-27-6 Cap screw

Spacer Ø4xØ5.5x3.25

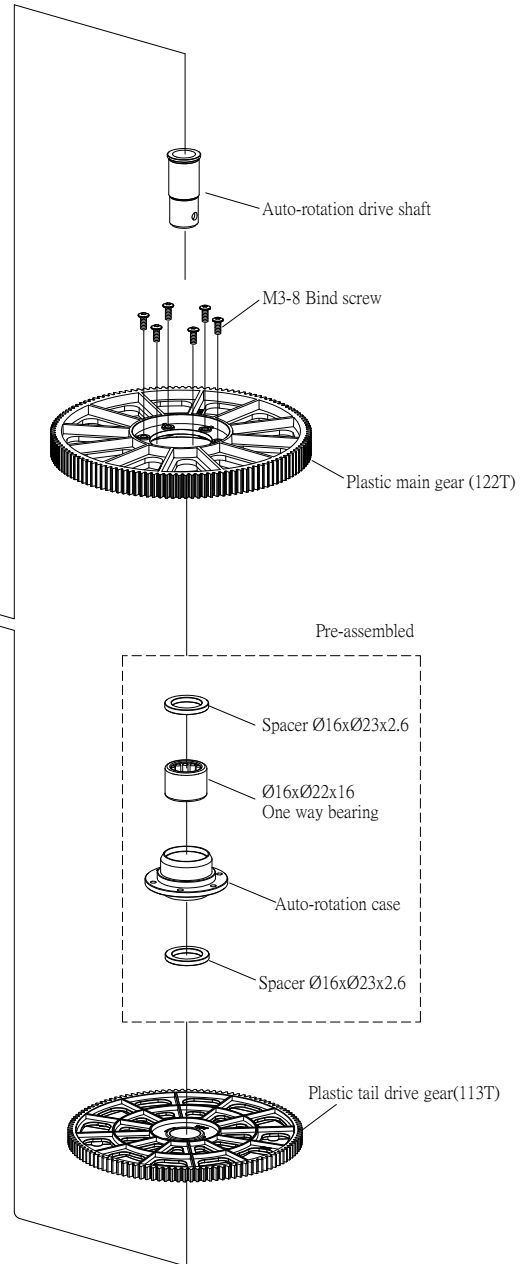

Auto-rotation drive shaft

M3-8 Bind screw

Plastic main gear (122T)

Pre-assembled

Spacer Ø16xØ23x2.6

Ø16xØ22x16 One way bearing

Auto-rotation case

Spacer Ø16xØ23x2.6

Plastic tail drive gear(113T)

Caution

Main shaft free play adjustment

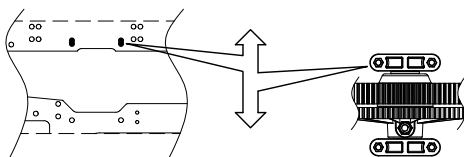



Loosen lower bearing block bolts. Insert main gear assembly and main shaft. While pressing up on the bearing block tighten the 4 lower bearing block bolts. Ensure no up/down free play by pulling on the main shaft.

17

Swashplate Assembly

T-016-00

 Please apply loctite when locking all metal screws .

-  M2-4 Bind Screw 4
-  12mm Ball 6

Assembly Tip

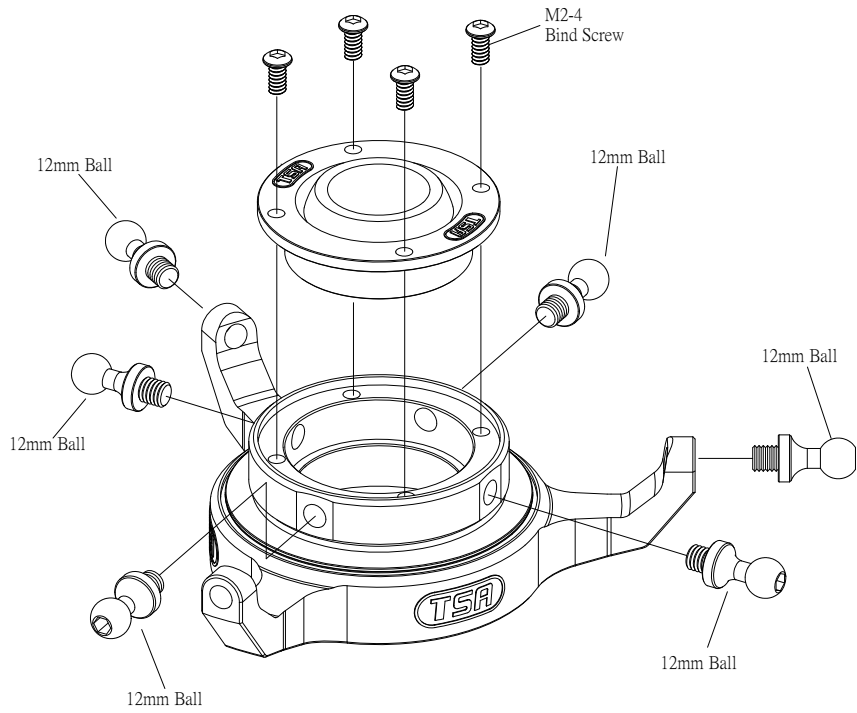
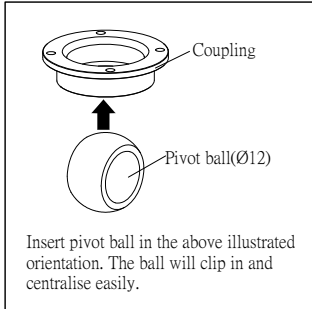



18

Washout Assembly

T-016-00

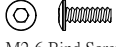
 Please apply loctite when locking all metal screws .

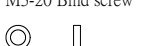
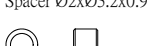
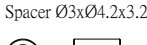
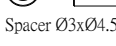
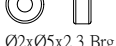
-  M2-6 Bind Screw 4
-  M3-20 Bind screw 2
-  Spacer Ø2xØ3.2x0.9 4
-  Spacer Ø3xØ4.2x3.2 2
-  Spacer Ø3xØ4.5x6.2 2
-  Ø2xØ5x2.3 Brg 4
-  Ø3xØ7x3 Brg 4

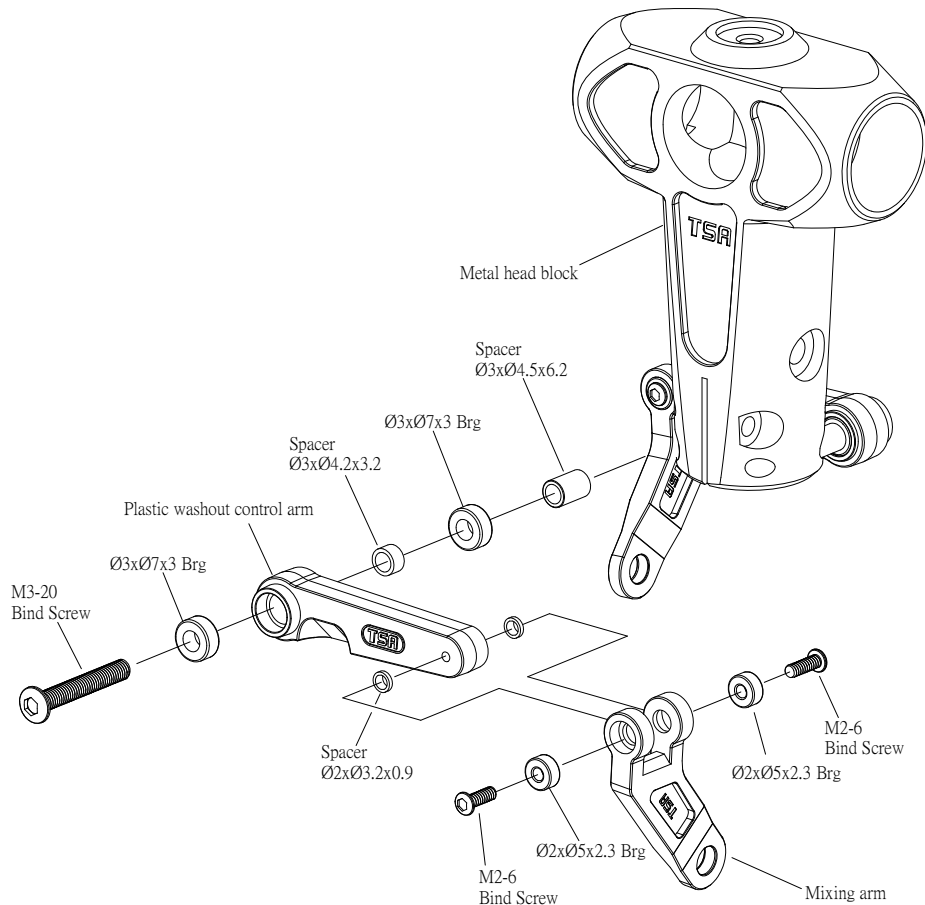

19

Pitch Arm Assembly

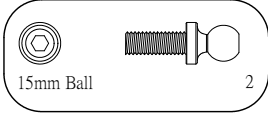

Please apply loctite when locking all metal screws .

T-016-00

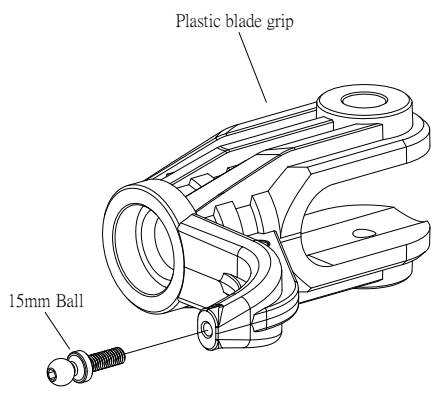

Caution
Two must be assembled

20

Head Block Assembly

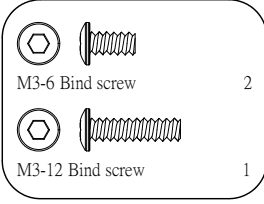

Please apply loctite when locking all metal screws .

T-016-00

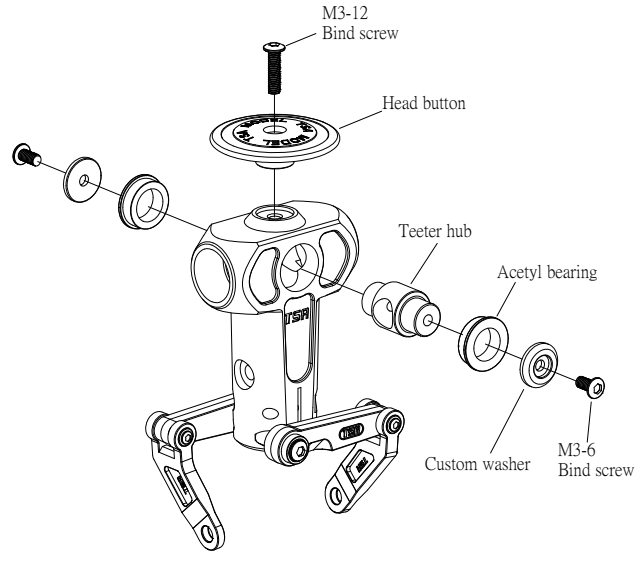

21

Blade Holder Assembly

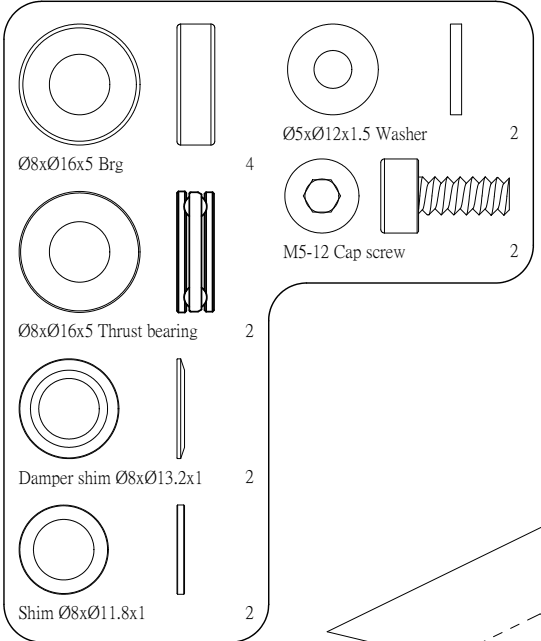

T-016-00

Please apply loctite when locking all metal screws .

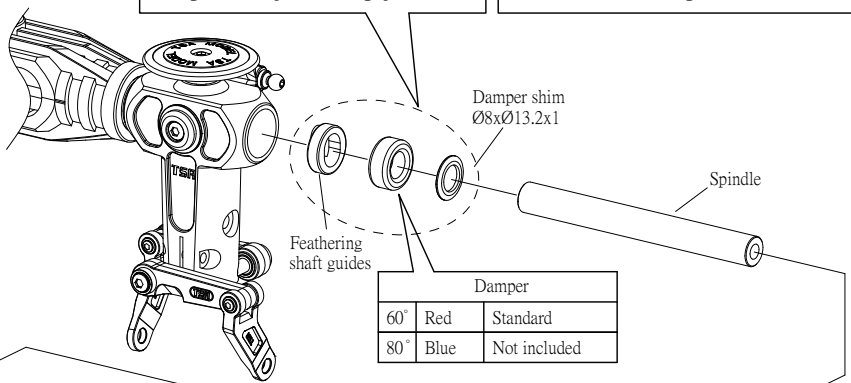
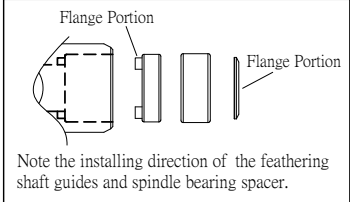
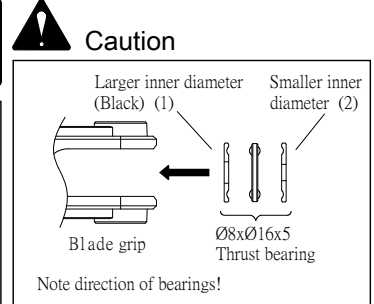



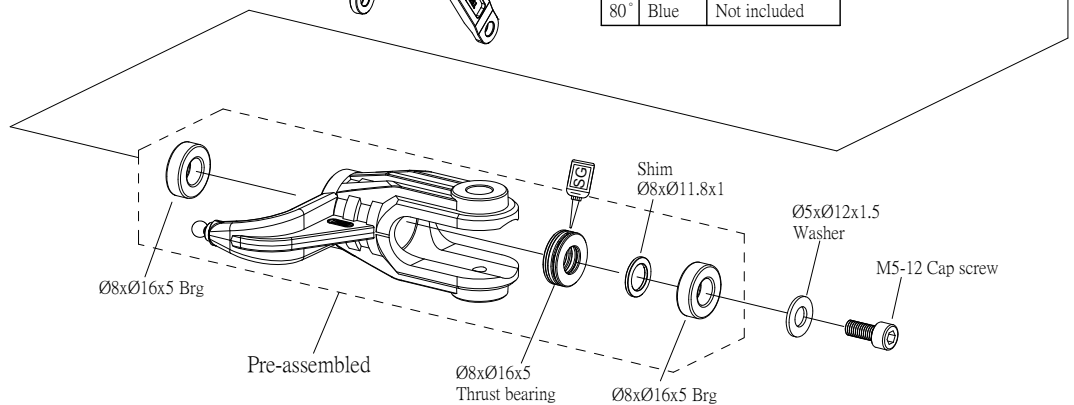

Damper		
60°	Red	Standard
80°	Blue	Not included



22

Rotor Head Complete Assembly

T-011-00
T-016-00
T-020-00

-  M3-18 SS 1
-  M3 Nylon nut 1
-  M4-5 Bind screw 2
-  Spacer Ø3xØ5x5.25 1
-  M3-15 Cap screw 2

 Please apply loctite when locking all metal screws .

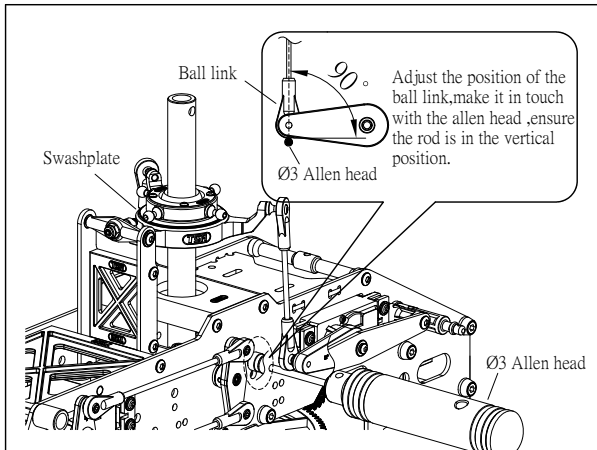
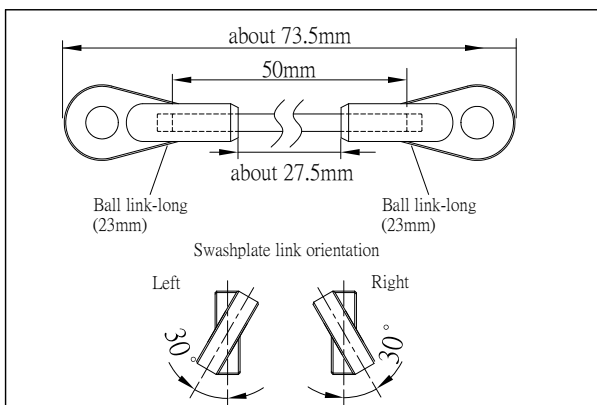

Insert the allen head into the hole as shown in the diagram , make sure the rocker-arm is parallel with the swashplate.

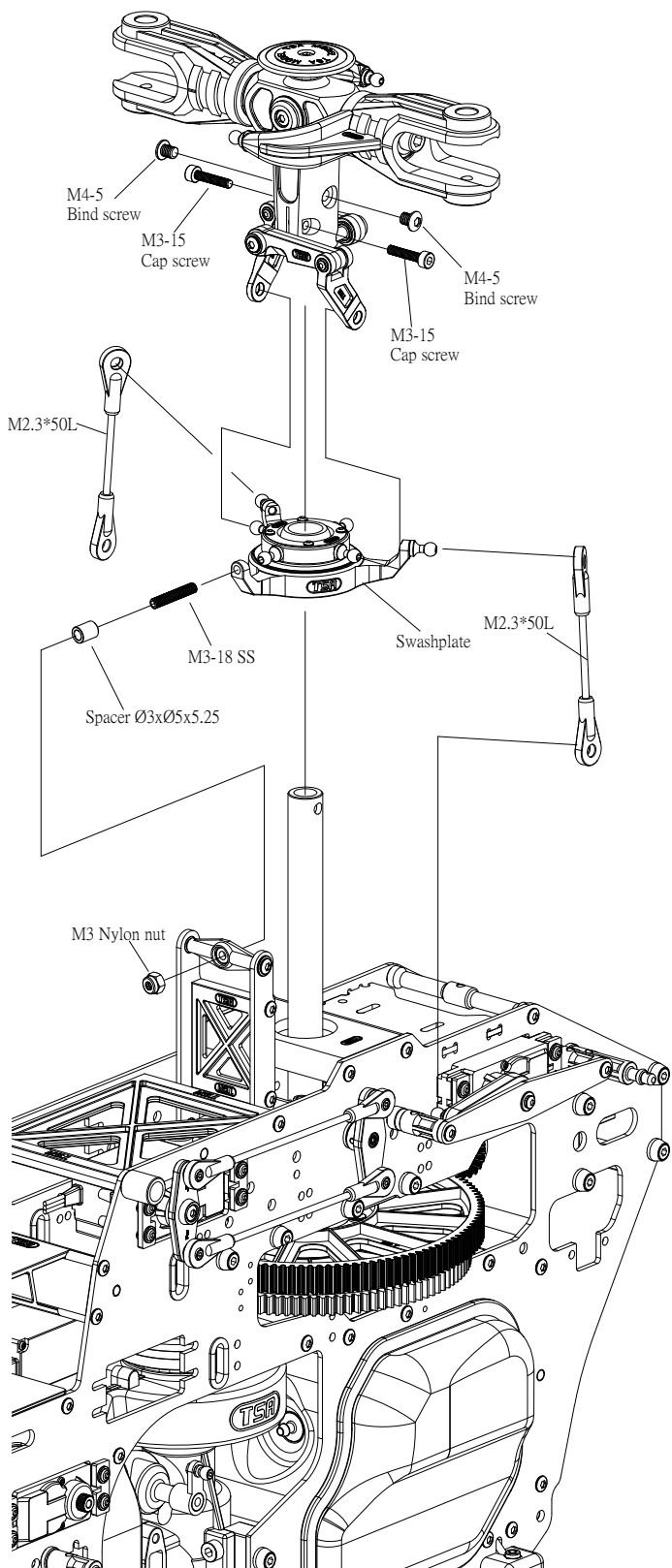
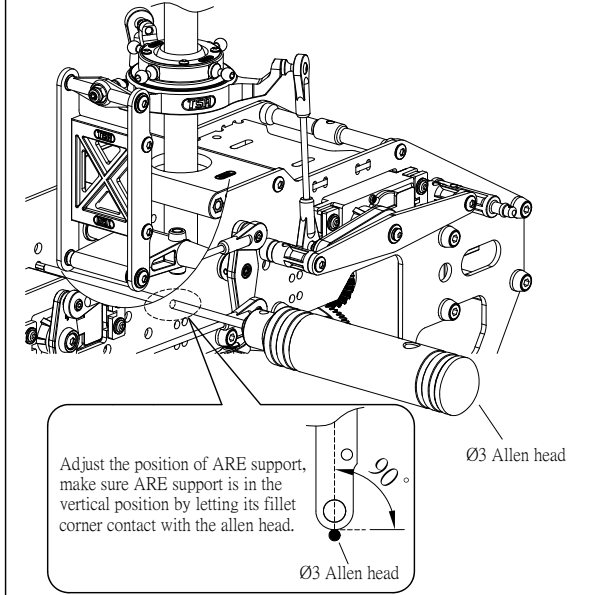

















23

Tail Gearbox Assembly-1

T-016-00

 Please apply loctite when locking all metal screws .

-   1
-   1
-   5
-   1
-   5
-   5
-   2
-   2

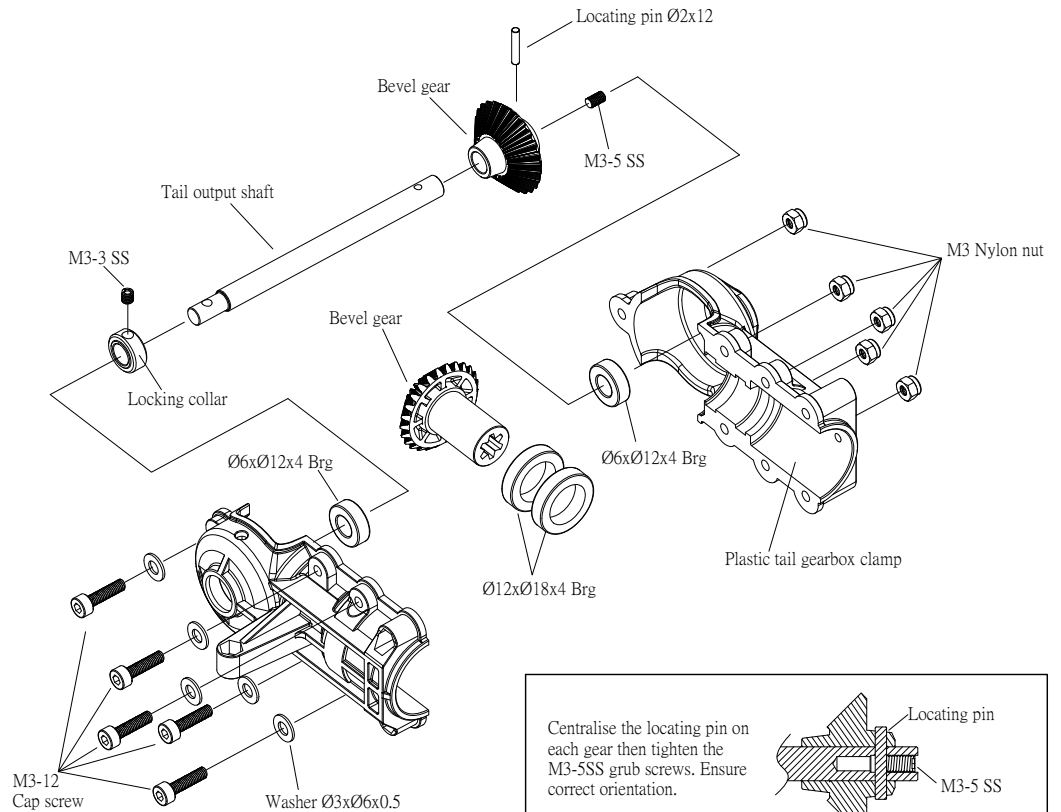















Centralise the locating pin on each gear then tighten the M3-5SS grub screws. Ensure correct orientation.

24

Tail Gearbox Assembly-2

T-017-00

 Please apply loctite when locking all metal screws .

-   1
-   2
-   1
-   2
-   2
-   1
-   2

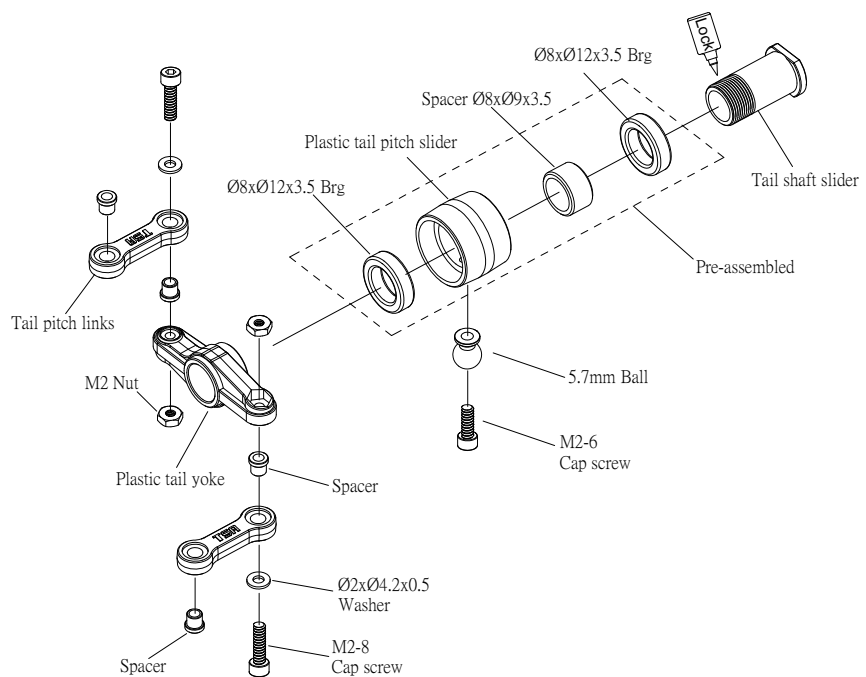







25

Tail Gearbox Assembly-3

T-018-01

 Please apply loctite when locking all metal screws .

-  M2-8 Cap screw 1
-  M3-20 Bind screw 1
-  5.7mm Ball 1
-  M2 Nut 1
-  M3 Nylon nut 1
-  Spacer Ø3xØ5x4.5 1
-  Spacer Ø3xØ4.5x3 1
-  Ø3xØ7x3 Brg 2

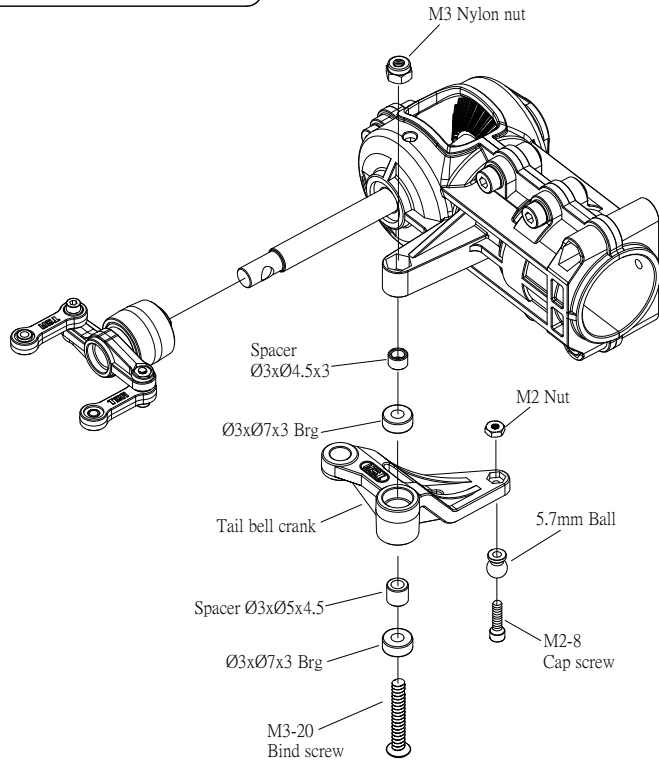





26

Tail Gearbox Assembly-4

T-016-00

 Please apply loctite when locking all metal screws .

-  M3-19-6 Cap screw 2
-  M3 Nylon nut 2
-  M4 Nylon nut 2
-  Ø5xØ10x4 Thrust bearing 2
-  Ø6xØ12x4 Brg 2

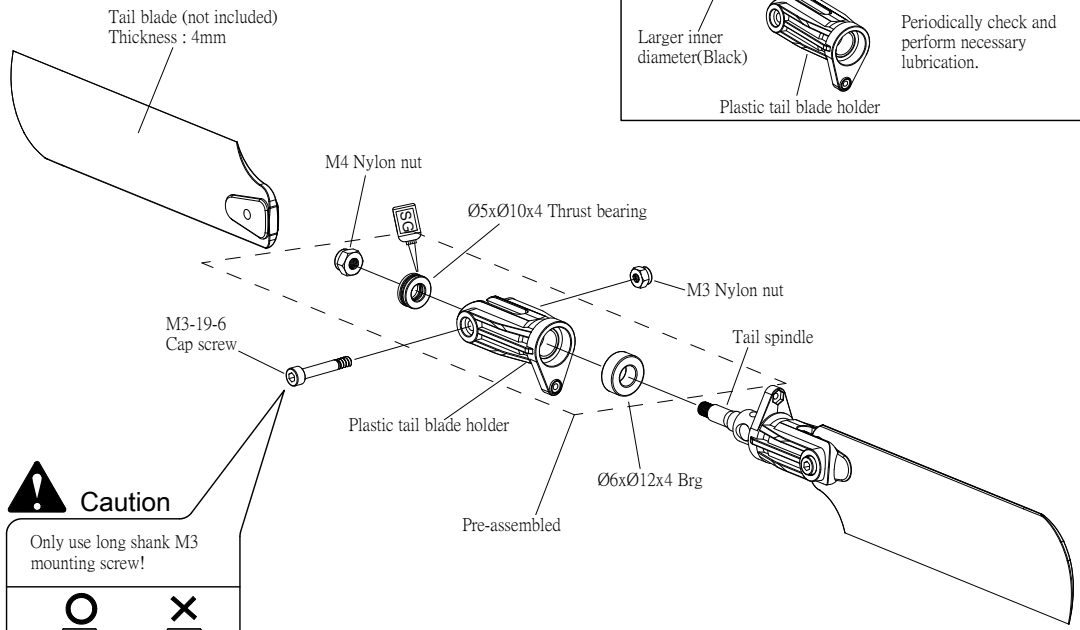

Caution
 Smaller inner diameter
 Larger inner diameter (Black)
 Plastic tail blade holder
 Note direction of bearings!
 Periodically check and perform necessary lubrication.

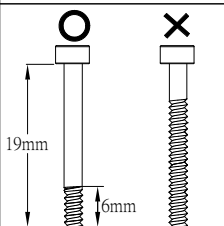
Caution
 Only use long shank M3 mounting screw!



Caution
 Fasten the tail blade to permit only slight movement .
 Note the direction of the tail blade and the tail blade grip.



27

Tail Gearbox Assembly-5

T-016-00

T-017-00

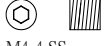
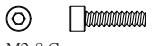
 Please apply loctite when locking all metal screws .

-  M4-4 SS 1
-  M2-8 Cap screw 2
-  Ø2xØ4.2x0.5 Washer 2
-  M2 Nut 2

Caution

Use the M4-4SS screw to fasten the tail shaft and spindle. Ensure grub screws are seated into receiver grooves.

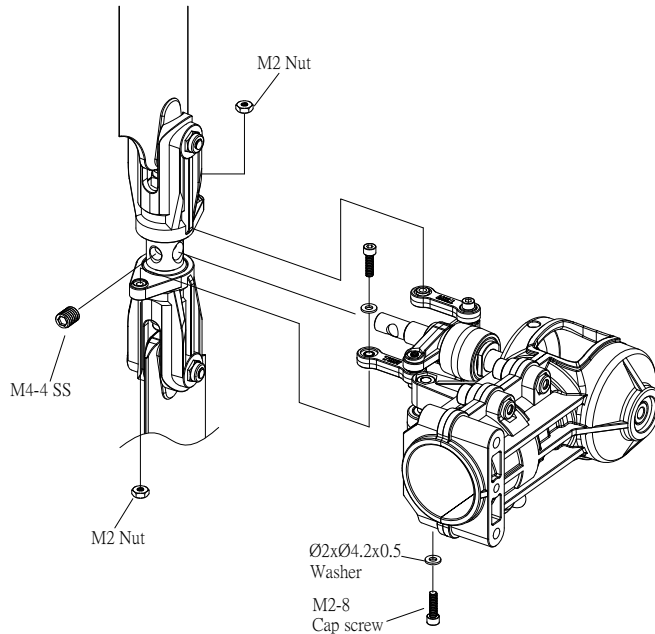
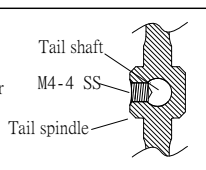

28

Tail Gearbox Assembly-6

T-026-03







T-027-00

T-028-00

 Please apply loctite when locking all metal screws .

Assembly Tip

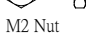
Apply oil to tail boom bearing carrier and inside tail boom for easy T/T installation.

-  M2-8 Cap screw 3
-  M3-8 PH screw 2
-  M3-10 Cap screw 1
-  M2 Nut 3
-  M3 Nylon nut 1
-  Ø8xØ14x4 Brg 2

Torque tube bearing location :

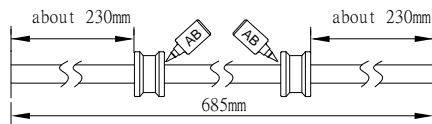

Apply AB glue to shaft then slide bearing overtop and allow to dry.

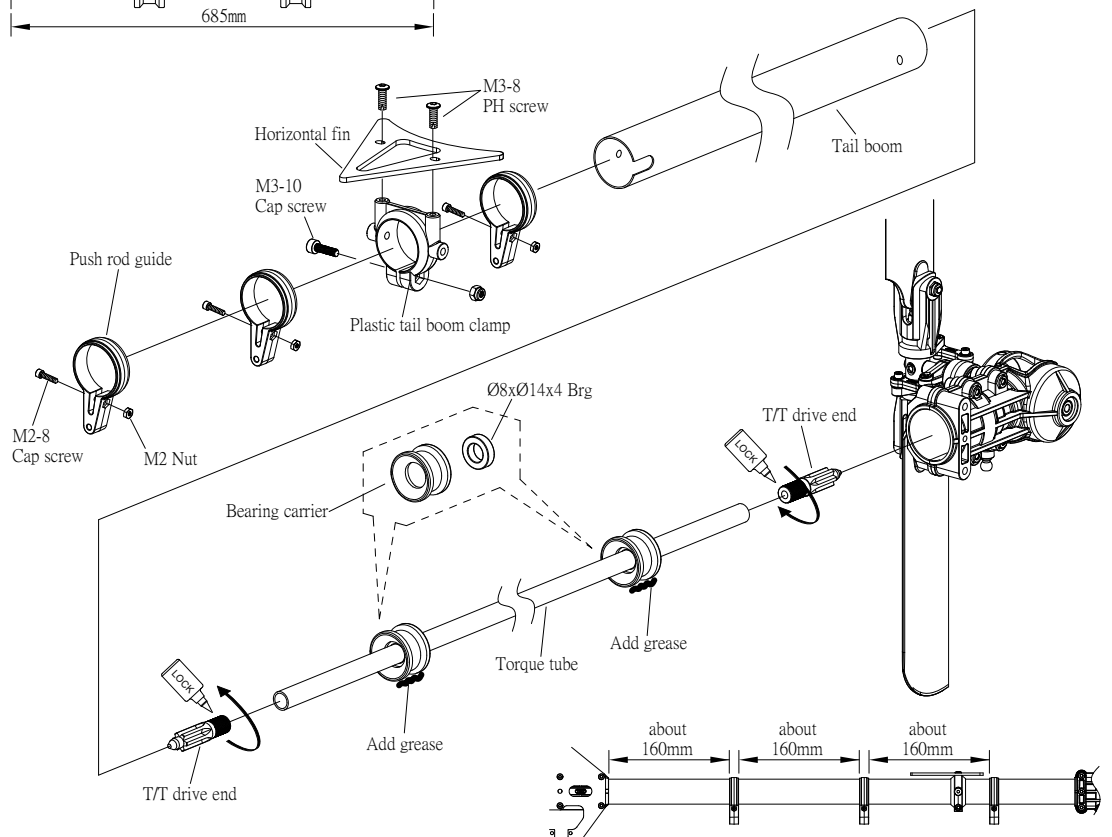









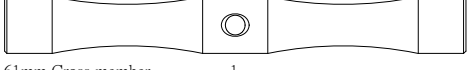

29

Tail Boom Support Assembly

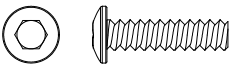
T-016-00
T-026-03
T-027-00
T-028-00

 Please apply loctite when locking all metal screws.

-  M3-25 Bind screw 2
-  M2 Nut 4
-  M2.6 Nut 4
-  M3 Nylon nut 3
-  M2.6-12-3 Bind screw 4
-  61mm Cross member 1
-  M2-10 Cap screw 4
-  M4-16 Bind screw 2
-  M3-5 Bind screw 1
-  M3-10 Cap screw 1
-  M4-12 Bind screw 2

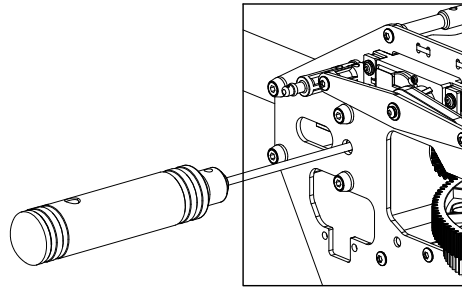

After inserting the tail boom tighten the previously installed retaining screw.

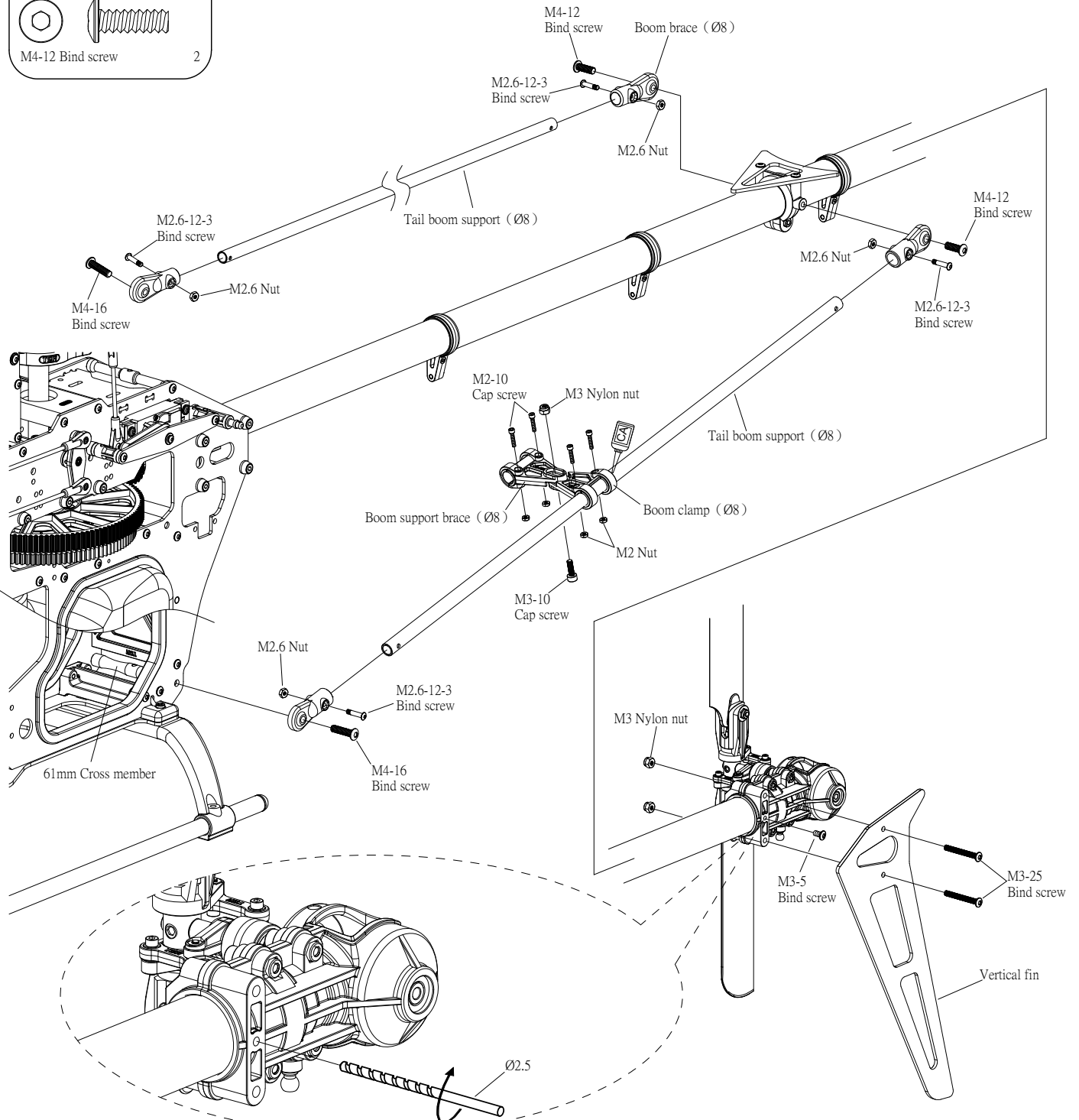

30

Rotor Head Linkage Assembly

T-016-00

 Please apply loctite when locking all metal screws .

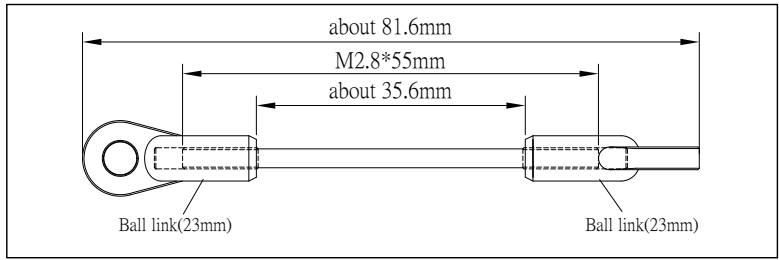
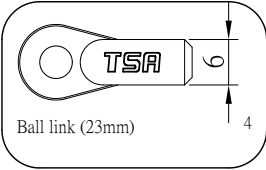

Caution

Measure the pitch angle after assembly of the blades, and then make the adjustment .

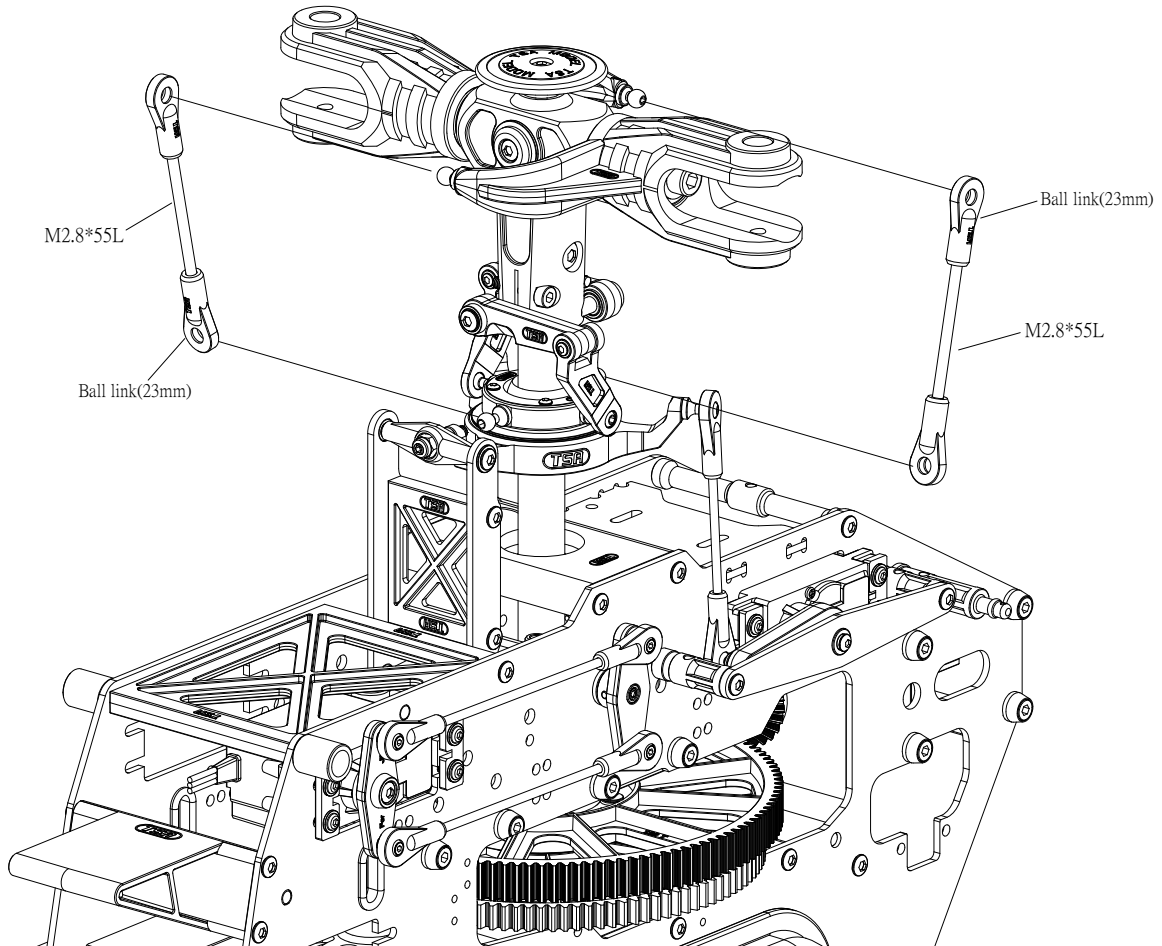

31







Linkage Rod Assembly

T-020-00

T-021-00

T-024-00

 Please apply loctite when locking all metal screws.

-   3
-   1
-  3
-  3

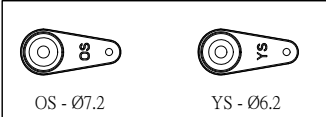
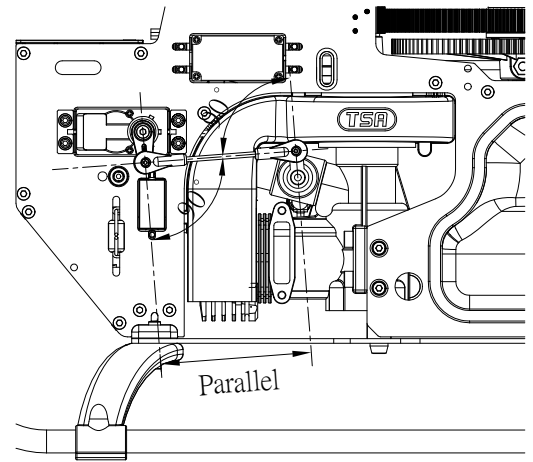
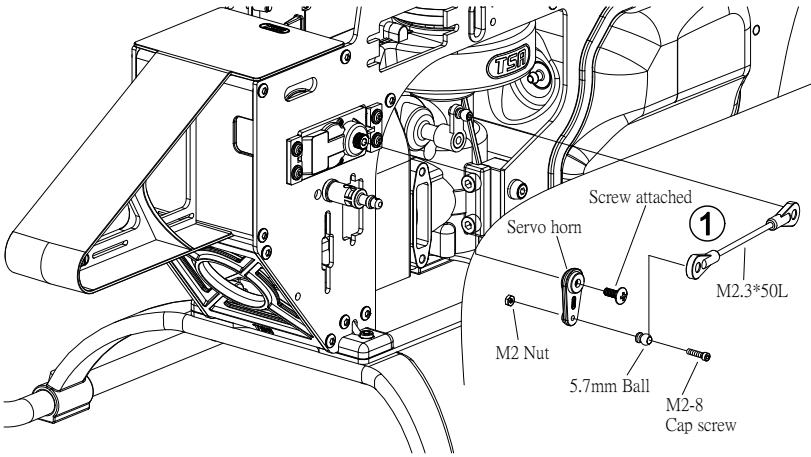
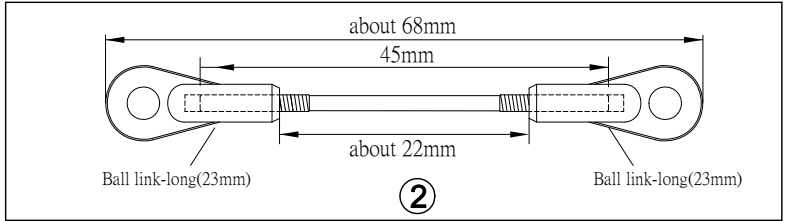
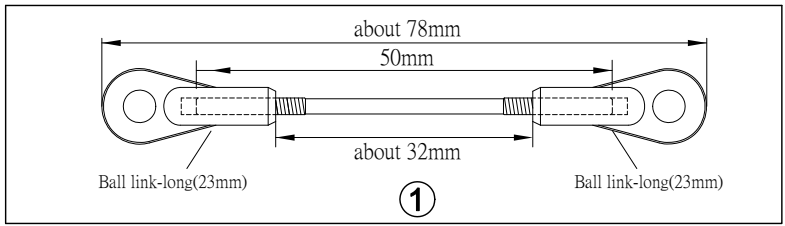

Both YS and OS mixture arms are provided. Please use the appropriate set for your application.

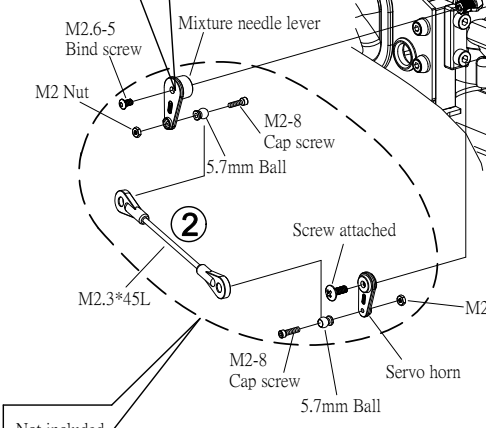

Not included

The rod's length varies depending on the servo. Adjust the length according to the instructions and verify once fitted on the model.

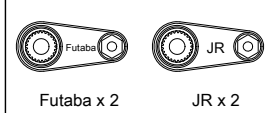

Both JR and Futaba servo horns are provided. Please use the appropriate set for your application.

Setup Tips

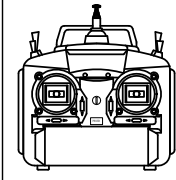





Turn on the transmitter before installing the servo rod, ensure the radio has a linear throttle/pitch curve and the throttle is set to mid stick 50% travel. This will enable close to equal travel limits for high/low throttle.

32

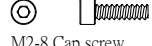

Rudder Linkage Assembly

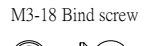
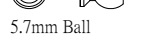
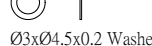
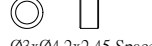
- T-023-00
- T-024-00
- T-027-00
- T-028-00

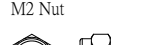
 Please apply loctite when locking all metal screws .

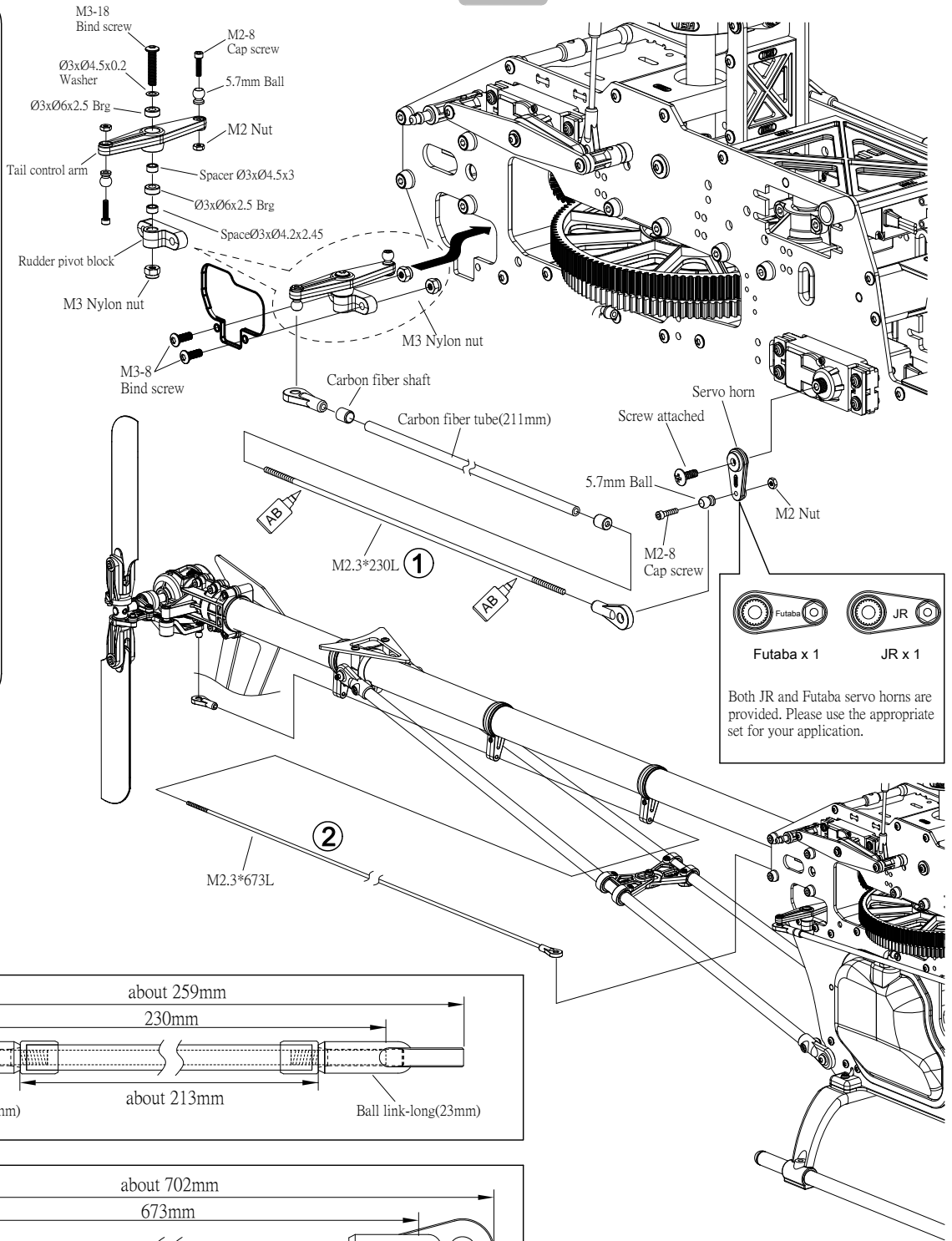
-  3
-  2
-  1
-  3
-  1
-  1
-  1
-  3
-  3
-  2



 Futaba x 1  JR x 1



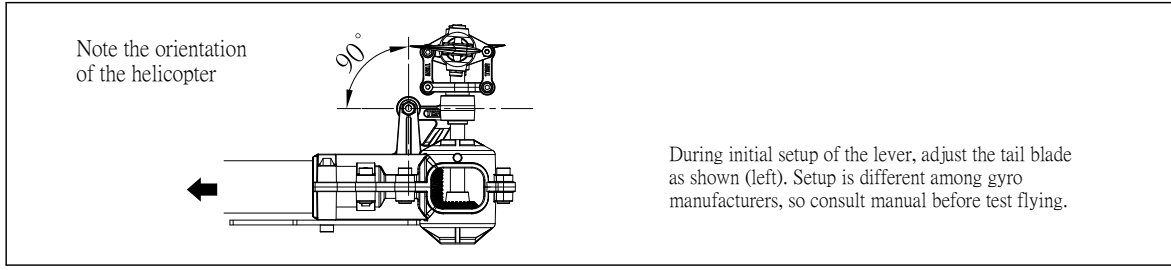
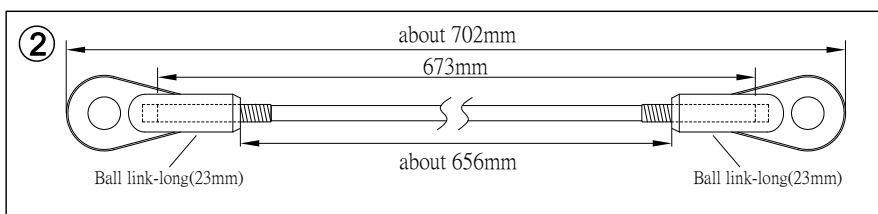
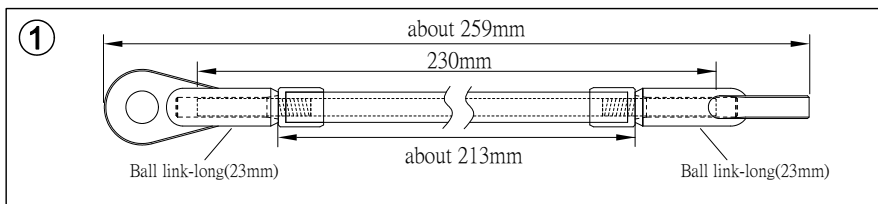

Both JR and Futaba servo horns are provided. Please use the appropriate set for your application.



33

Main Blade Assembly

T-016-00

		2
		2

 **Caution**

Only use long shank M4 mounting screw!

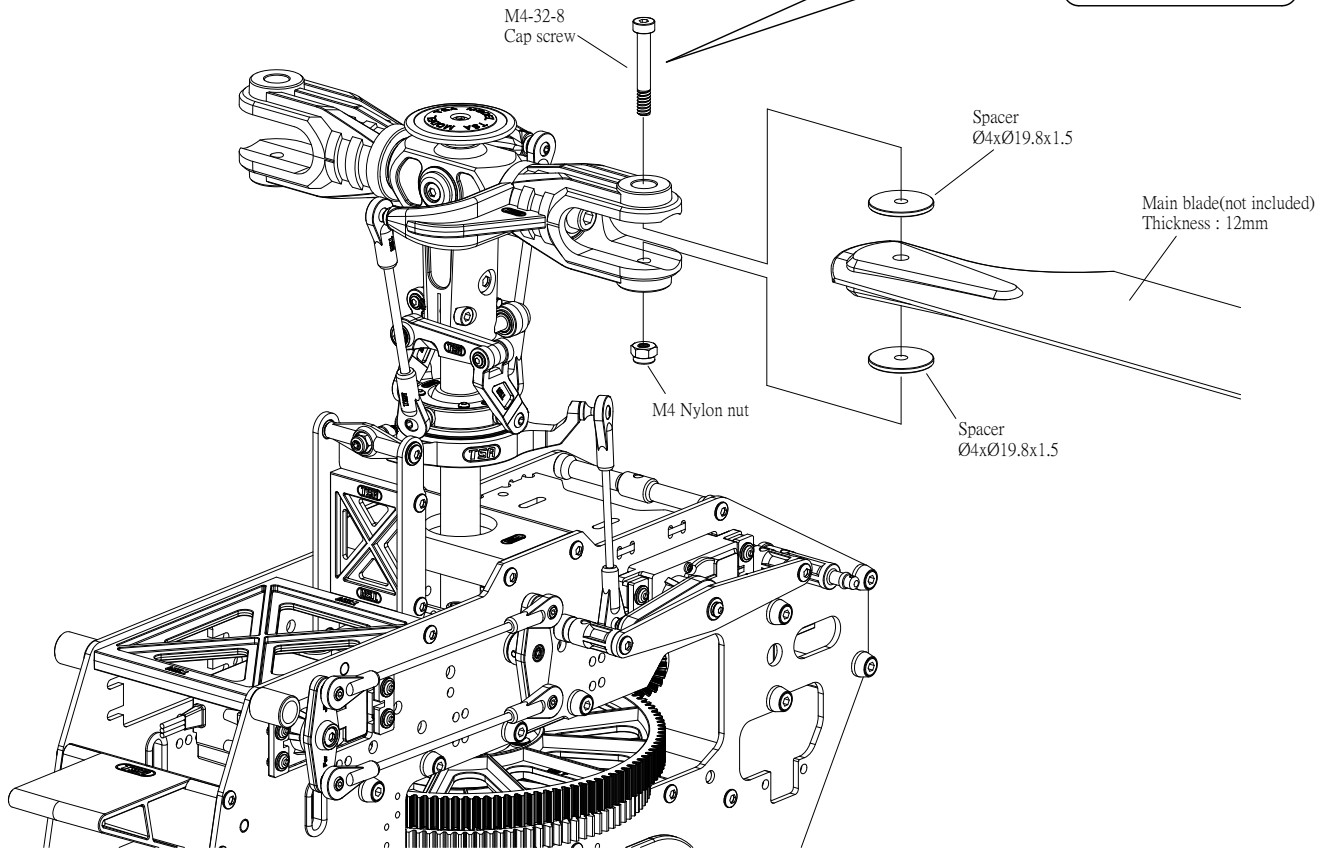
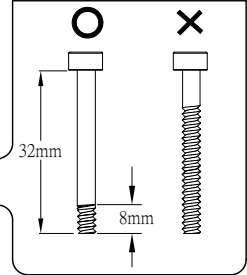

34

Receiver and Gyro Assembly

Caution

The gyro sensor has a special orientation when installed. Install it according to the gyro's instruction manual .

For JR

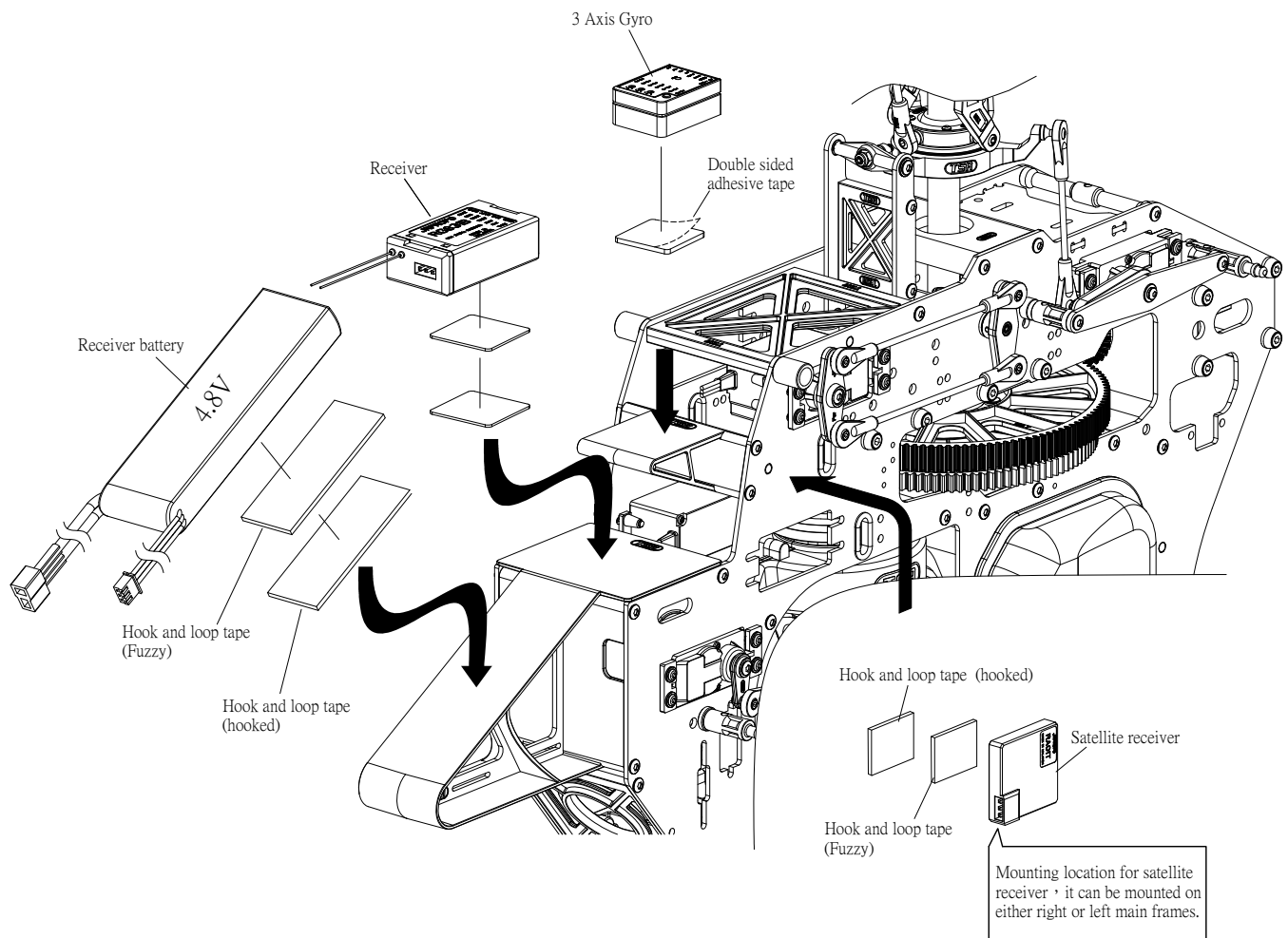
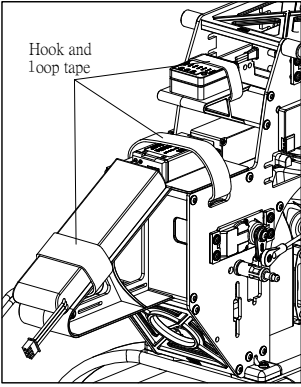

Caution

The electrical control system as stated above shall be assembled in according to its corresponding instruction manual.

35

Electrical Control System Wiring Diagram

JR / 7CH receiver wiring

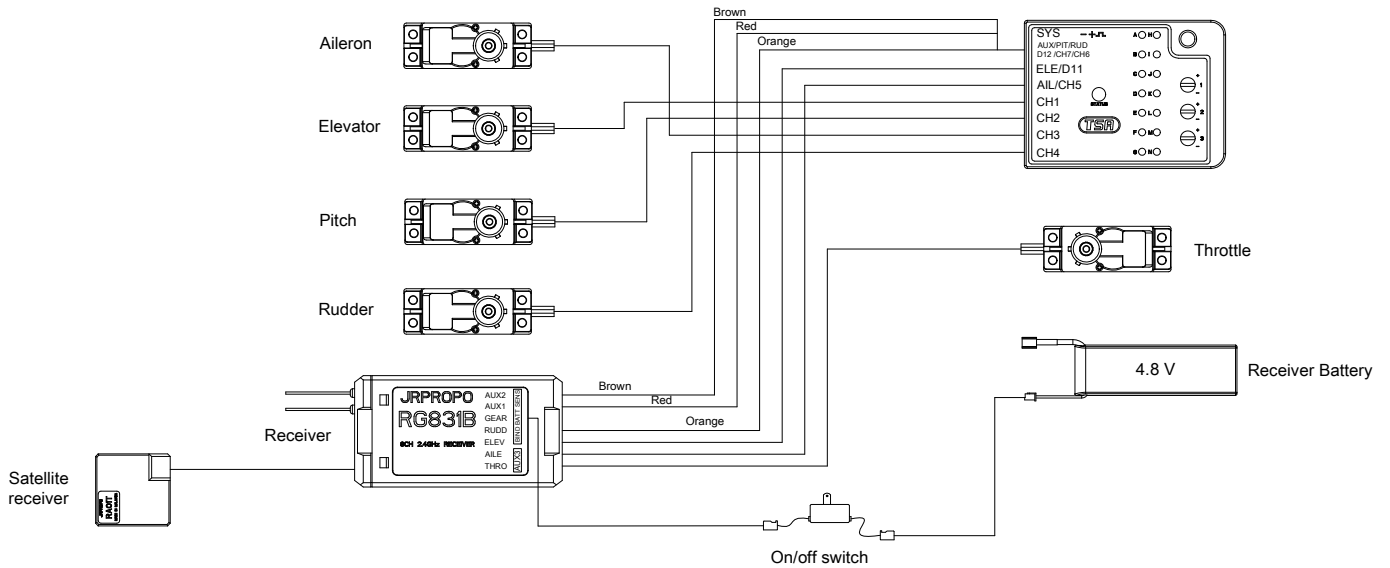

JR / 7CH receiver wiring/Governor

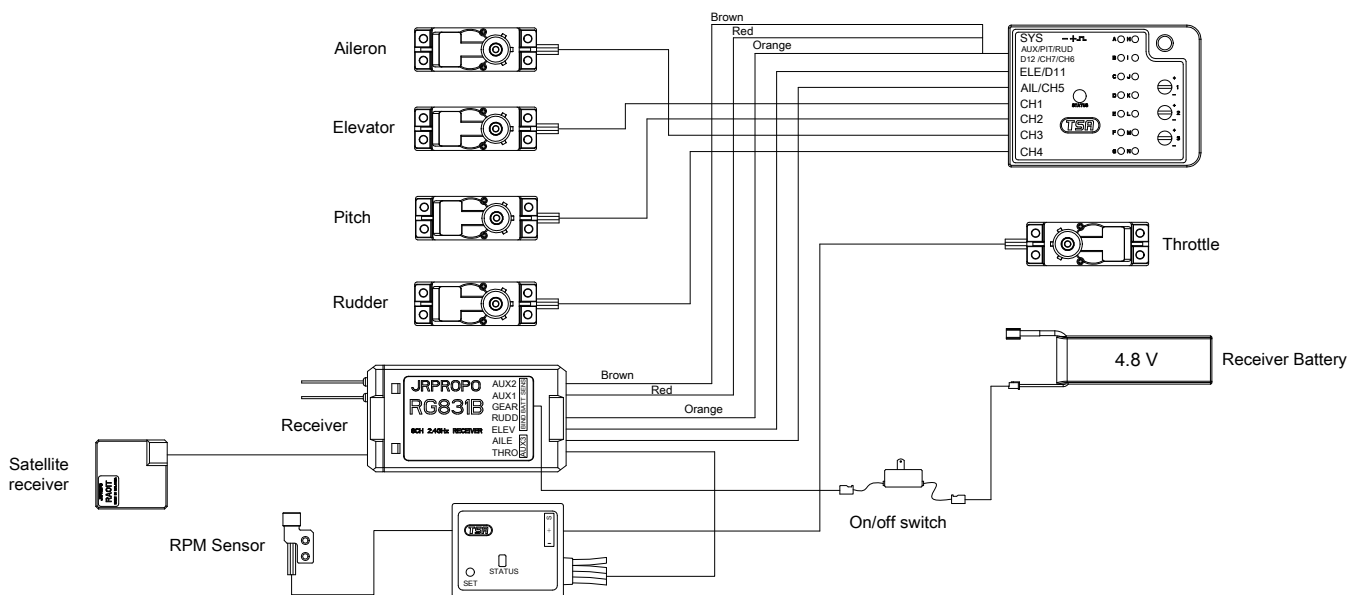

36

Muffler Assembly

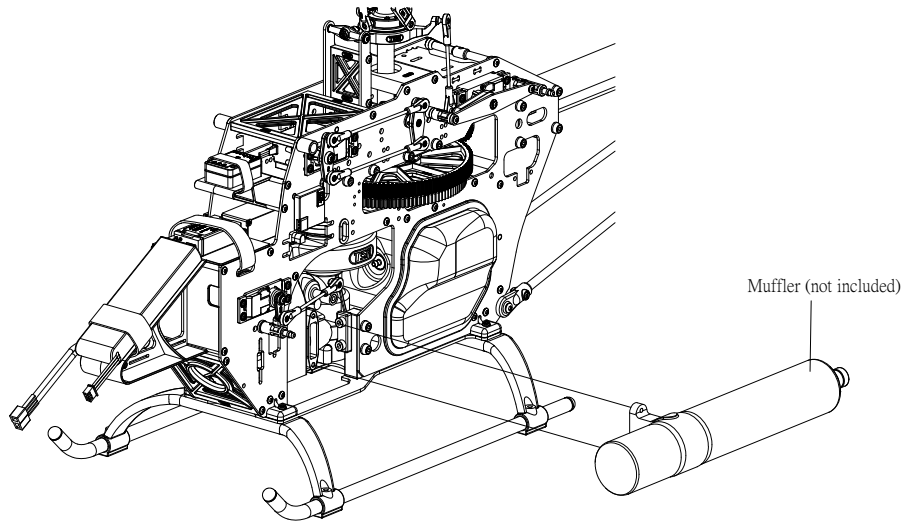

37

Canopy Assembly

T-005-00

Optional custom designed canopies are available. Please check website for availability.

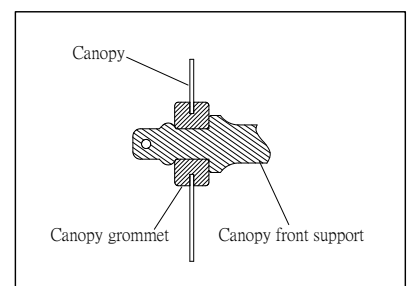
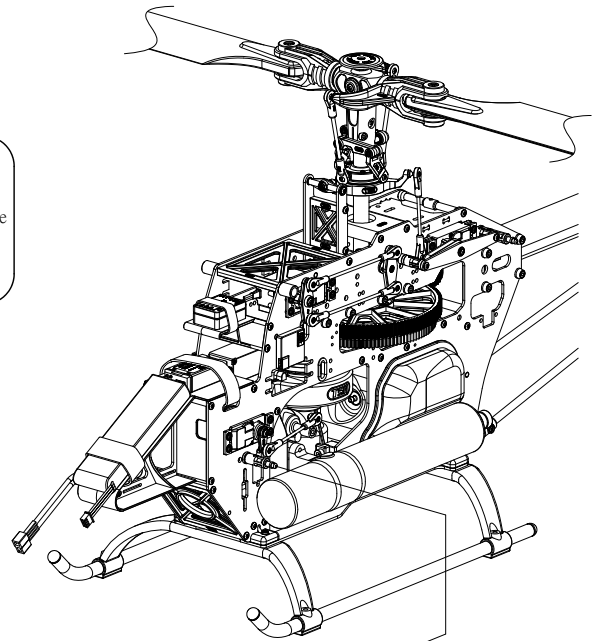
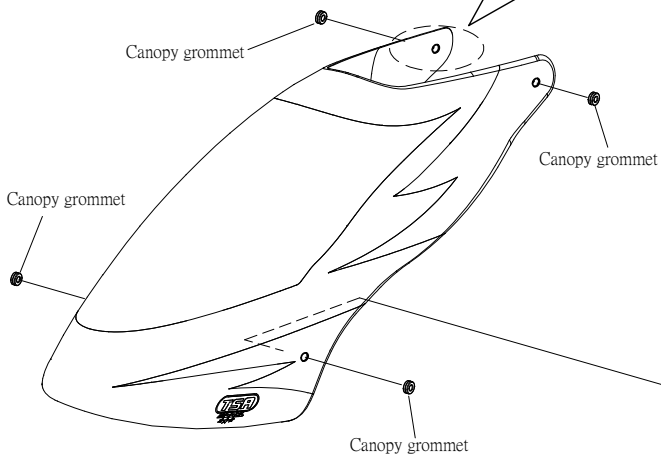
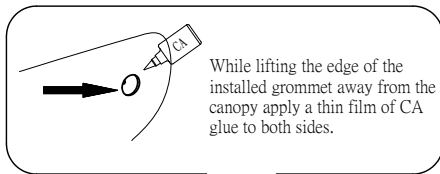
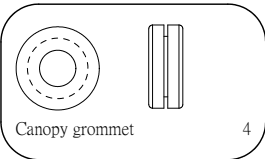



Flybarless gyro setup-3 Axis gyros

Caution

Please refer to the Flybarless gyro instruction manual for setting up the cyclic and tail servo along with the rotor head. This will be specific for each system.



Main blade adjustment

Caution

Precaution during initial setup is for the safety of yourself and others, so please make sure the heli is flying at least 10m away from any person.

1. Increase pitch slowly until the helicopter comes to a stable hover. Note any separation in the rotor blades.
2. Observe the blade tracking:
If main blades are in the same track, then no adjustment required. However, if one blade appears higher than the another blade, then adjustments must be made.
3. Adjust pitch rod tracking:
A. Main blade is higher → reduce length of linkage rod
B. Main blade is lower → add the length of linkage rod

Caution

Improper tracking will result in vibration, Adjust track until both blades are tracking in the same plane.

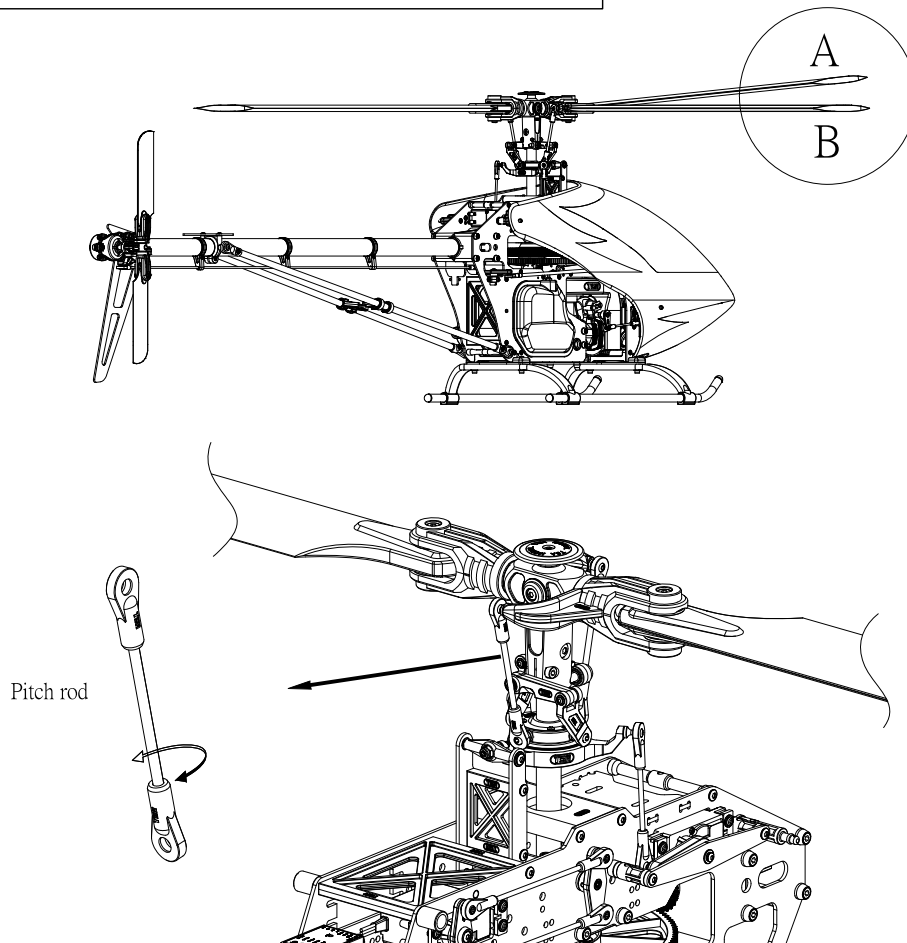



Caution Beginners should know the designated operating mode of (TSA)600N-3D before operating to avoid accidents

(Mode 1)

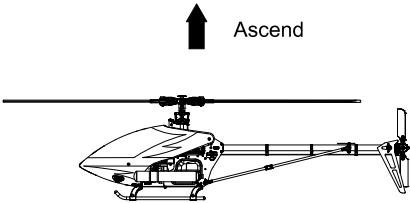
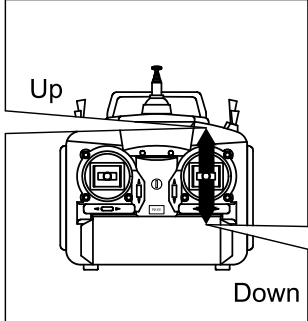
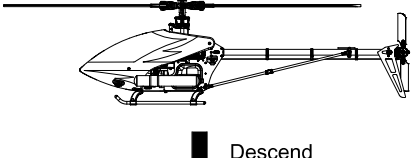
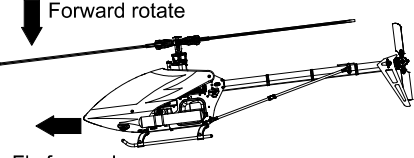
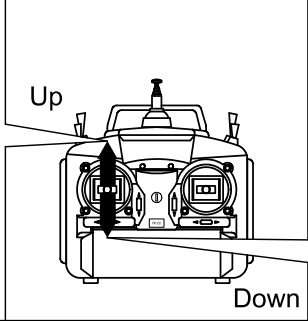
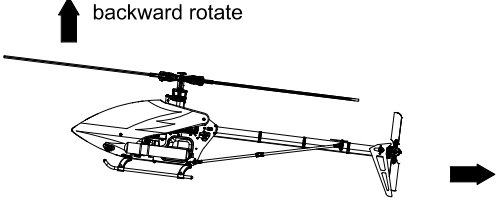
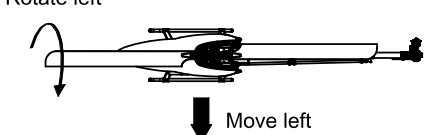
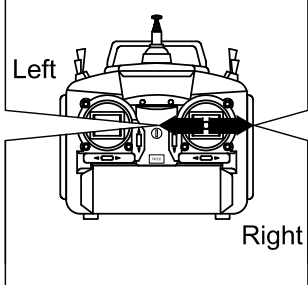
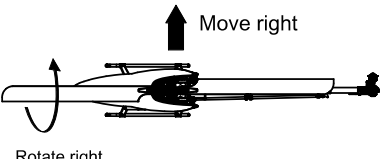
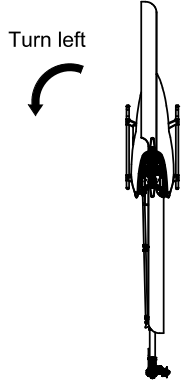
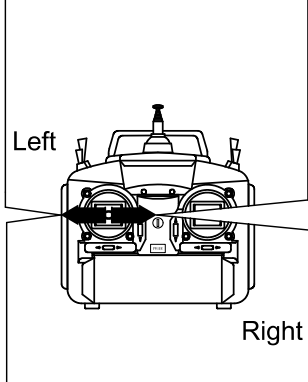
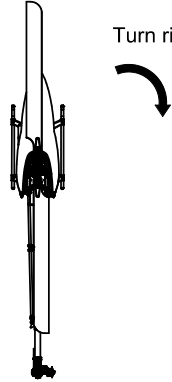
 <p>Ascend</p> <p>Pushing the pitch control upward will cause the unit to ascend.</p>	<p>Throttle / Pitch</p>  <p>Up</p> <p>Down</p>	 <p>Descend</p> <p>Push the pitch control down, then the unit will descend.</p>
 <p>Forward rotate</p> <p>Fly forward</p> <p>Pushing the elevator control up, then the unit will go forward.</p>	<p>Elevator</p>  <p>Up</p> <p>Down</p>	 <p>backward rotate</p> <p>Fly backward</p> <p>Push the elevator control down, then the unit will go backward.</p>
 <p>Rotate left</p> <p>Move left</p> <p>Push the aileron control left, the unit will move to the left.</p>	<p>Aileron</p>  <p>Left</p> <p>Right</p>	 <p>Move right</p> <p>Rotate right</p> <p>Push the aileron control right, then the unit will move to the right.</p>
 <p>Turn left</p> <p>Push the rudder control to the left , the body and nose of unit will rotate to the left.</p>	<p>Rudder</p>  <p>Left</p> <p>Right</p>	 <p>Turn right</p> <p>Push the rudder control to the right, the body and nose of unit will rotate to the right .</p>



Caution

Beginners should know the designated operating mode of (TSA)600N-3D before operating to avoid accidents

(Mode 2)

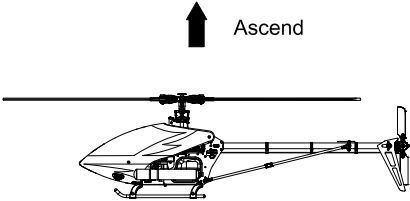
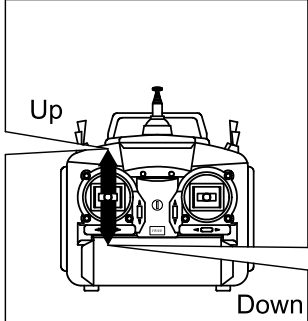
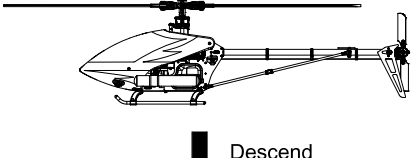
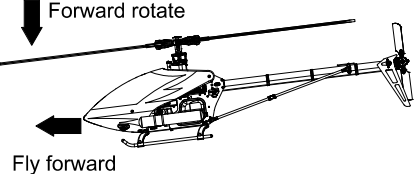
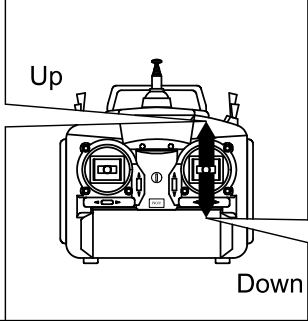
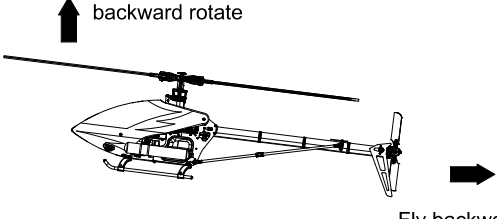
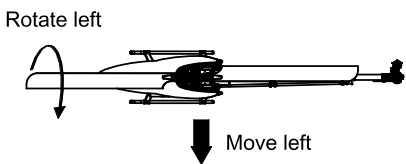
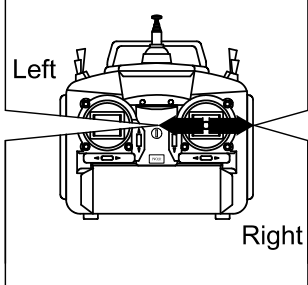
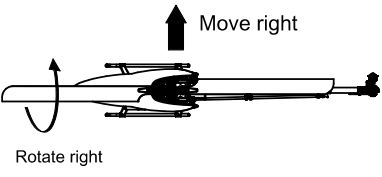
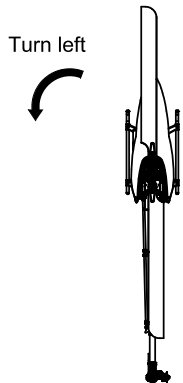
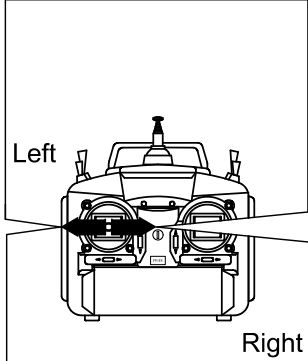
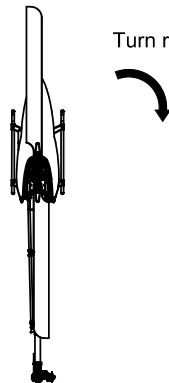
 <p>Ascend</p> <p>Pushing the pitch control upward will cause the unit to ascend.</p>	<p>Throttle / Pitch</p>  <p>Up</p> <p>Down</p>	 <p>Descend</p> <p>Push the pitch control down, then the unit will descend.</p>
 <p>Forward rotate</p> <p>Fly forward</p> <p>Pushing the elevator control up, then the unit will go forward.</p>	<p>Elevator</p>  <p>Up</p> <p>Down</p>	 <p>backward rotate</p> <p>Fly backward</p> <p>Push the elevator control down, then the unit will go backward.</p>
 <p>Rotate left</p> <p>Move left</p> <p>Push the aileron control left, the unit will move to the left.</p>	<p>Aileron</p>  <p>Left</p> <p>Right</p>	 <p>Move right</p> <p>Rotate right</p> <p>Push the aileron control right, then the unit will move to the right.</p>
 <p>Turn left</p> <p>Push the rudder control to the left, the body and nose of unit will rotate to the left.</p>	<p>Rudder</p>  <p>Left</p> <p>Right</p>	 <p>Turn right</p> <p>Push the rudder control to the right, the body and nose of unit will rotate to the right.</p>

The helicopter's main and tail rotors spin at very high speed. Make sure to follow these instructions to ensure a safe and enjoyable flight.

Transporting the unit

When transporting the unit to an airfield, secure it to prevent the unit from tipping over. Avoid causing damage to the components which may adversely affect flight performance and safety.

The airfield

Do not fly

1. Near people ,
2. Near buildings ,
3. Near roads, railway tracks, or power lines .

Check the unit before flight

Check that all of the screws are securely fastened. New unit tends to have loose screws. Make sure to check them all before each flight. Check that the transmitter and receiver batteries are fully charged.

The distance of flight

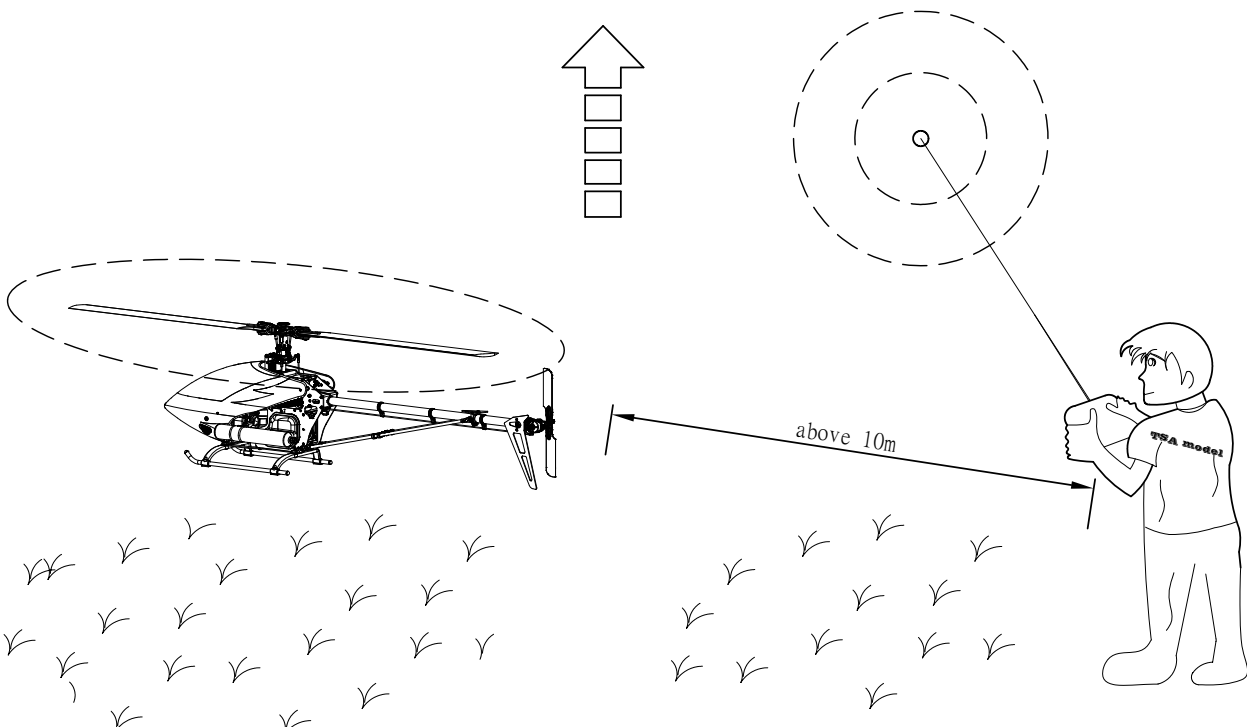
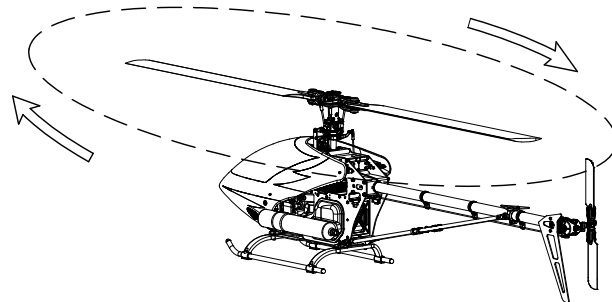

Spare parts

※Order Number:TPA00100XX(Left)

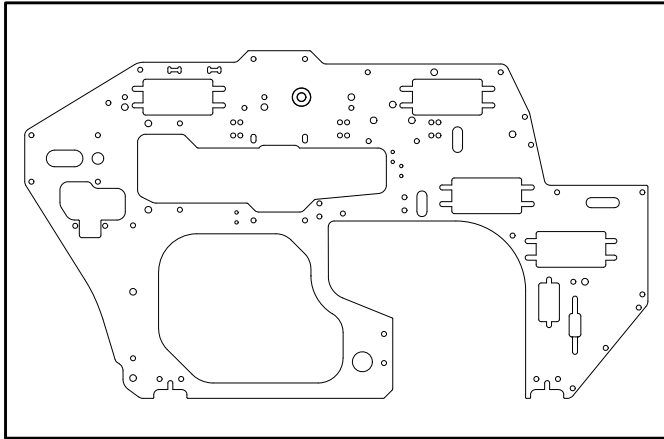

※Order Number:TPA00101XX(Right)

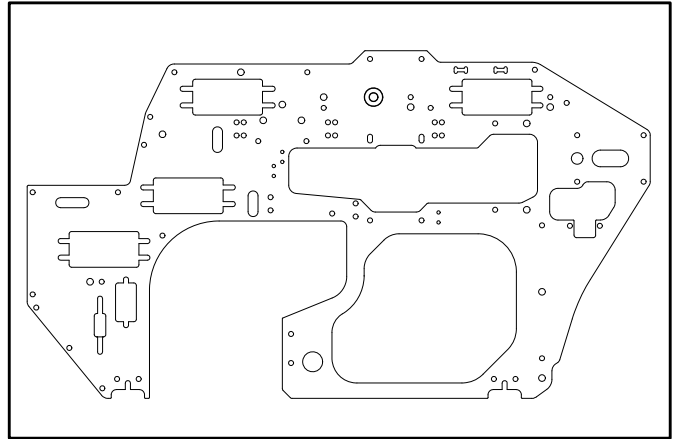

Order Number:TPA00402XX

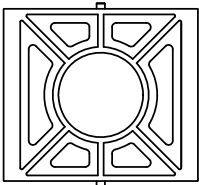

Rigidity brace

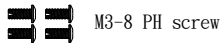

Order Number:TPA0276000

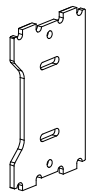

Gyro Plate

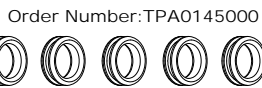

Grommet

Order Number:TPA0145000

Order Number:TPA00304XX

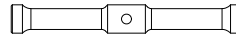

Cross member

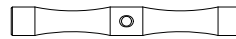

Cross member

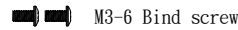

Order Number:TPA00400XX

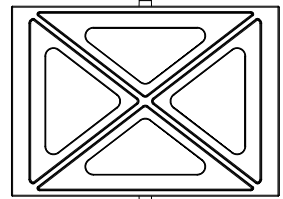
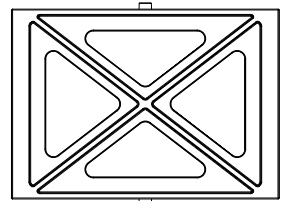

Rigidity brace

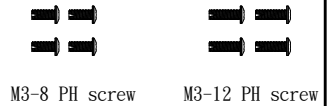

Order Number:TPA00500XX



Gyro mount

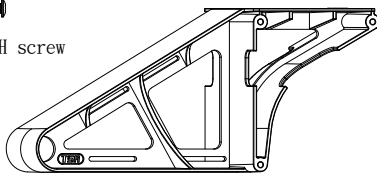
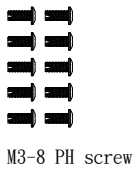

Battery mount

Order Number:TPA00600XX

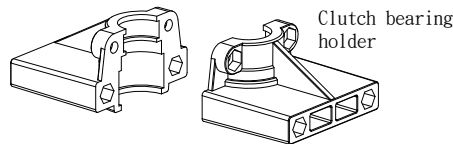

Clutch bearing holder

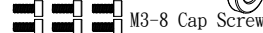
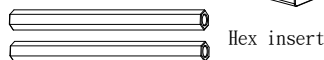

Order Number:TPA01300XX

Order Number:TPA01000XX

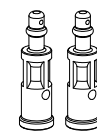

Canopy front support

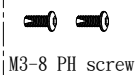

Order Number:TPA01200XX

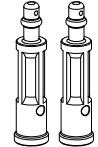

Canopy rear support

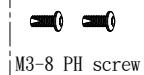

※Order Number:TPA00903XX

※Order Number:TPA00702XX

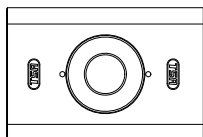

Main bearing holder

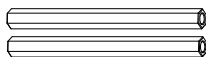

Hex insert



※Order Number:TPA00800XX

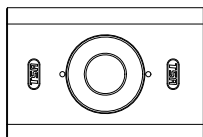

Main bearing holder

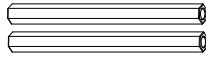

Hex insert

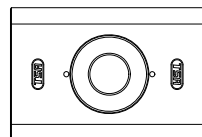
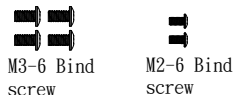

Main bearing holder

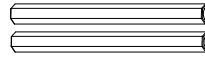

Hex insert

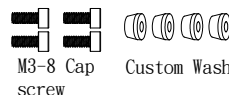

Order Number:TPA01100XX



Canopy damper



Flange washer

※Parts with this symbol have been assembled by the bearing factory !

Order Number:TPA01600XX

Order Number:TPA01400XX

Landing skid

M4-4 SS

Order Number:TPA01500XX

Landing skid tube

Order Number:TPA01900XX

0337-000
Plastic Skid Mount

- M3-12 PH screw
- M3-18 Cap screw
- M3 Nut
- Washer (03x08x0.8)

Order Number:TPA01800XX

Fan shroud

Hex insert

M3-6 Bind screw

Order Number:TPA02200XX

Fuel tank (600CC)

Fuel fitting
Hex nut
Fuel tank grommet

Order Number:TPA02010XX

Fuel tube(Ø2.5x04x90mm)

Fuel tube(Ø2.5x05.5x500mm)

Order Number:TPA02000XX

Fuel tank pickup
Fuel inducer
Inducer cover
Fuel tank nipple

M3-5 Stainless steel bind screw

Order Number:TPA0147000

Fuel tank guard

Order Number:TPA0261000

Base plate

Order Number:TPA0340000

Plastic tail boom clamp

Order Number:TPA02700XX

Bearing 06x013x5
Bearing 012x018x4

Order Number:TPA02500XX

Hex insert
Custom Washer
M3-8 Cap screw
M3-6 Bind screw
M3-8 Bind screw

Order Number:TPA02600XX

Bevel gear
Locating pin (02*11mm)
M3-5 SS

Order Number:TPA02900XX

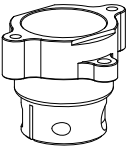

Fan hub



M3-6 Bind screw

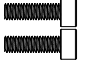

M3-10 Cap screw



Spacer 06*013*2



M3-6 Cap screw

Order Number:TPA03000XX

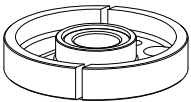

Clutch

Order Number:TPA0325000

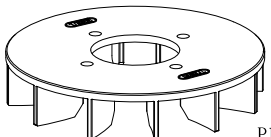

Plastic fan

Order Number:TPA03400XX

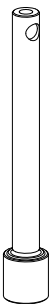

Clutch shaft



Starter coupling



M4-5 SS

Order Number: TPA03100XX



Retainer nut



Spur gear

***Order Number: TPA03200XX**



Clutch bell

Order Number: TPA0380000

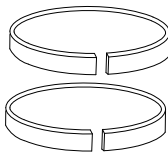

Clutch liner

*** Order Number:TPA03300XX**

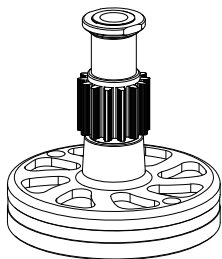

Order Number:TPA0042000

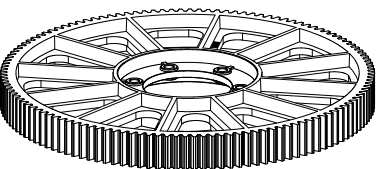

Plastic main gear(122T)

Order Number: TPA0121002

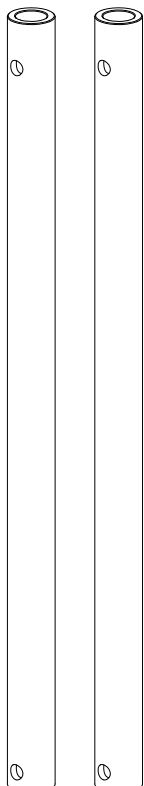

Main shaft

***Order Number:TPA03500XX**

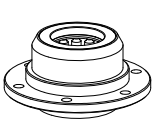

M3-8 Bind screw



Order Number:TPA0122010

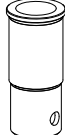

Auto-rotation drive shaft

Order Number:TPA03600XX

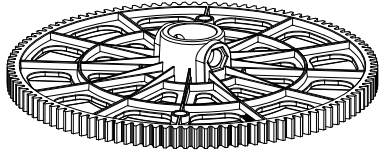

Plastic tail drive gear



Spacer(04*05.5*3.25)

Order Number:TPA03800XX



M4 Nylon nut

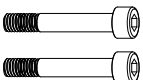

M4-27-6 Cap screw

Order Number:TPA03900XX

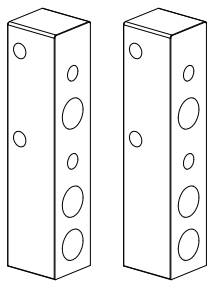

Engine mount

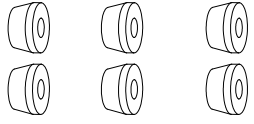

Custom Washer

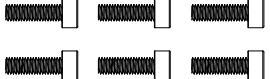

M3-10 Cap screw

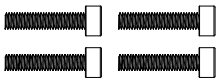

M3-15 Cap screw

❖ **Order Number: TPA04600XX**

Spacer (3*5*5, 25mm)

M3-18 SS

M3 Nylon nut

Order Number: TPA04000XX

Pivot Arm

Spacer M3-10 Bind screw M4-4 SS (03*04, 2*2, 45)

Order Number: TPA04100XX

Elevator shaft

Locating pin (02*11mm) M3-4 SS M3-6 Bind screw

Order Number: TPA04200XX

Plastic elevator lever

5.7mm Ball

M2 Nut

M2-8 Cap screw

Order Number: TPA04300XX

ARE rocker-arm support

M3-8 PH screw

❖ **Order Number: TPA04400XX**

ARE supports

❖ **Order Number: TPA04500XX**

Plastic Pivot block

M3-18 SS

M3-12 Bind screw

M3 Nylon nut

Spacer (3*5*5, 25mm)

❖ **Order Number: TPA20100XX**

12mm Ball

M2-4 Bind screw

Order Number: TPA20000XX

Coupling

Pivot ball

Order Number: TPA20200XX

15mm Ball

12mm Ball

13mm Ball

❖ **Order Number: TPA20400XX**

❖ **Order Number: TPA20300XX**

Washout control arm

Spacer (02*03, 2*0, 9mm)

M2-6 Bind screw

Order Number: TPA0306000

Mixing arm

Order Number: TPAB00100X

02x05x2, 3 Bearing

Order Number: TPA04700XX

5.7mm Ball

M2 Nut

M2-8 Cap screw

Order Number: TPA20900XX

Order Number: TPA20800XX

Metal Head block

M4-5 Bind screw

M3-15 Cap screw

Spacer (Ø3*Ø4.5*6.2mm)

M3-20 Bind screw

Order Number: TPA20600XX

Teeter hub

Acetyl bearing

Custom washer

M3-6 Bind screw

Order Number: TPA0201000

Damper shim (Ø8*Ø13.2*1mm)

Order Number: TPA0302000

Feathering shaft guide

Order Number: TPA0140002

Damper60° (Red)

Order Number: TPA20700XX

Head button

M3-12 Bind screw

Order Number: TPA20500XX

Spindle (Ø8*89.9mm)

M5-12 Cap screw

Ø5xØ12x1.5 Washer

✳ Order Number: TPA21200XX

Blade grip

Spacer (Ø4*Ø19.8*1.5mm)

15mm Ball

M4 Nylon nut

M4-32-8 Cap screw

Order Number: TPA21003XX

M4 Nylon nut

M4-32-8 Cap screw

Order Number: TPA21300XX

Rod (M2.8*55mm)

Ball link (23mm)

✳ Order Number: TPA42000XX

M3 Nylon nut

M3-19-6 Cap screw

M4-4 SS

✳ Order Number: TPA41900XX

Tail blade grip

Order Number: TPA41700XX

Tail spindle

M4-4 SS

M4 Nylon nut

Order Number: TPA41800XX

M3 Nylon nut

M3-19-6 Cap screw

Order Number: TPA42100XX

- spacer (03*04.5*3mm)
- M3 Nylon nut
- M3-20 Bind screw

Order Number: TPA02300XX

Bevel gear

Bevel gear

Order Number: TPA41300XX

- spacer (03*04.5*3mm)
- M3-5 Bind screw
- M3-20 Bind screw
- M3-25 Bind screw
- Tail gearbox clamp
- M3-12 Cap screw
- 03x06x0.5 Washer
- M3 Nylon nut

Order Number: TPA40900XX

- Metal tail output shaft
- Locating pin (02x12mm)
- M3-5 SS

Order Number: TPA41302XX

- 06x012x4 Bearing
- 012x018x4 Bearing

Order Number: TPA40800XX

- Locking collar
- M3-3 SS

Order Number: TPA41000XX

- Tail bell crank
- 5.7mm Ball
- M2-8 Cap screw
- M2 Nut

Order Number: TPA40002XX

- Plastic tail boom clamp
- M3-8 PH screw
- M4-12 Bind screw
- M3 Nylon nut
- M3-10 Cap screw

Order Number: TPA41400XX

- Tail pitch links
- 02x04.2x0.5 Washer
- Spacer
- M2-8 Cap screw

Order Number: TPA41600XX

Order Number: TPA42304XX

Vertical fin

Horizontal fin

Order Number: TPA04800XX

- Servo support
- M3-8 PH screw

Order Number: TPA05000XX

- M3 Nylon nut
- M3-8 Bind screw

Order Number: TPA04900XX

- M2.6-12 Bind screw (Futaba)
- M3-12 Bind Screw (JR)
- Servo support guide
- Servo support plate

Order Number: TPA05200XX

- Rod (M2.2*50mm)
- Rod (M2.8*55mm)
- Rod (M2.2*80mm)

Order Number: TPA05100XX

- Rod (M2.2*230mm)
- Carbon fiber tube (211mm)
- Carbon fiber shaft
- Ball link-long

Order Number:TPA05500XX

Servo horn (JR)

5.7mm Ball

M2 Nut M2-8 Cap screw

Order Number:TPA05300XX

Ball link

Ball link-long

Order Number:TPA05400XX

Lever (JR)

13mm Ball

Order Number:TPA05700XX

Servo mounting plate

Servo mounting plate

M2.6-18 PH screw

Order Number:TPA05501XX

Servo horn (Futaba)

5.7mm Ball

M2 Nut M2-8 Cap screw

Order Number:TPA06500XX

Wire clamp

Wire clamp

Wire clamp

Order Number:TPA05401XX

Lever (Futaba)

13mm Ball

Order Number:TPA40201XX

Boom support brace(Ø8)

Boom clamp (Ø8)

M2 Nut M2-10 Cap screw M3 Nylon nut M3-10 Cap screw

Order Number:TPA40102XX

Push rod guide

M2-8 Cap screw

M2 Nut

Order Number:TPA0333000

Servo plate

Order Number:TPA0172000

T/T drive end

Order Number:TPA40301XX

Boom support end(Ø8)

M2.6-12-3 Bind screw M2.6 Nut

Order Number:TPA40600XX

Bearing carrier

Order Number:TPA40700XX

Topque tube(685mm)

Order Number:TPA40500XX

Ball link-long (23mm)

Rudder rod (M2.2*673mm)

Order Number:TPA40401XX

Tail boom support(Ø8*532mm)

Order Number:TPA0083001

Tail boom (692mm)

Order Number:TPA90000XX

Silicone grease Retainer 5 minute epoxy

Order Number:TPA60001XX

Canopy

Canopy grommet

Specifications

★ Full length of fuselage -----	1235mm
★ Full width of fuselage -----	215mm
★ Height -----	390mm
★ Flying weight (approx) -----	3410g
★ Main rotor diameter -----	1345mm
★ Tail rotor diameter -----	252mm
★ Engine class -----	50~55 Nitro
★ Gear ratio -----	8.7:1:4.52
★ Main gear ratio -----	14T:122T
★ Tail gear ratio -----	113T:25T
★ Full tank capacity -----	650cc
★ Main blade (not included) -----	600~620mm
★ Tail blade (not included) -----	90mm

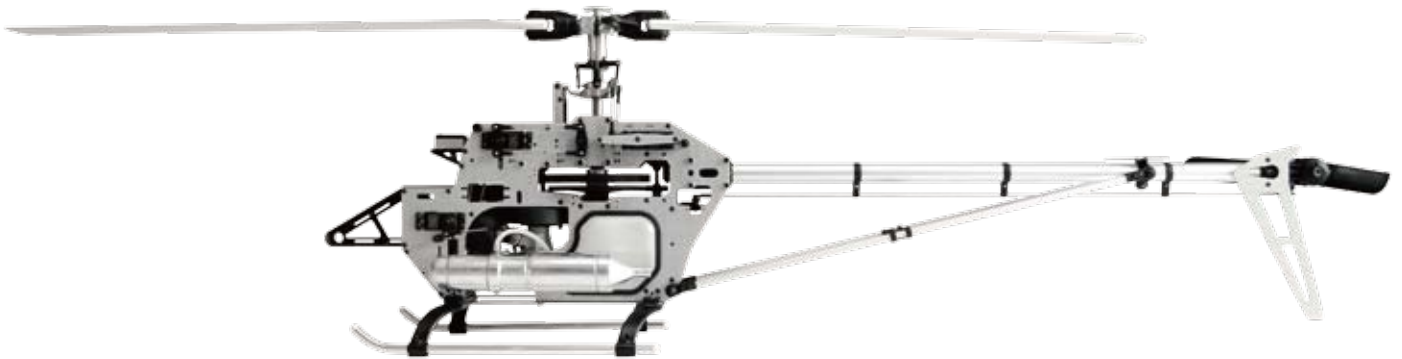

***** **INFUSION 600N**
Pro

Customer Support: sales@tsamodel.com



Safety Precautions

Helicopter spinning blades are potential dangerous. Please ensure to maintain a minimum distance of 10m from the aircraft at all times. It is the responsibility of the builder to ensure the aircraft is airworthy and safe to operate in the designated area. On going maintenance is required by the operator to ensure continuous safe use and all damaged parts should be replaced immediately.

Small components are included in the kit, please ensure the kit parts are kept out of children's reach, as they are small enough to swallow.

Use only TSA Model genuine parts, failure to do so could result in damage to both the aircraft and personal in the area. TSA Model takes no responsibility for the operational use of the aircraft.



Caution

Reproduction of the manual and any TSA components are strictly prohibited.

The contents of this manual are subject to change without prior notice.

Every effort has been made to ensure that this manual is complete and correct.