

KDS MODEL

inova 550 INSTRUCTION MANUAL 使用说明书



www.kdsmodel.com

1. INTRODUCTION 前言

Thank you for buying KDS Products. The KDS 550 Helicopter is designed as an easy to use, full featured helicopter R/C model capable of all forms of rotary flight. Please read the manual carefully before assembling the model, and follow all precautions and recommendations located within the manual. Be sure to retain the manual for future reference, routine maintenance, and tuning. The KDS 550 is a new product developed by KDS. It features the best design available on the micro-Heli market to date, providing flying stability for beginners, full aerobatic capability for advanced fliers, and unsurpassed reliability for customer support.

感谢您选购KDS 产品，为了让您容易方便的使用KDS 550直升机、请您详细的阅读完这本说明书之后再行组装以及操作这台直升机，同时请您妥善的保存这本说明书、作为日后进行调整以及维修的参考。KDS 550是由KDS自行研发的新产品，不论你是需求飞行稳定性的初学者或是追求性能的飞行爱好者。KDS 550将是你最佳的选择。

IMPORTANT NOTES 重要声明

R/C helicopters, including the KDS 550 are no toys. R/C helicopters utilize various high-tech products and technologies to provide superior performance. Improper use of this product can result in serious injury or even death. Please read this manual carefully before using and make sure to be conscious of your own personal safety and the safety of others and your environment when operating all KDS products. Manufacturer and seller assume no liability for the operation or the use of this product. Intended for use only by adults with experience flying remote control helicopters. After the sale of this product we cannot maintain any control over its operation or usage.



It is not a Toy!

KDS 550 遥控直升机并非玩具，它是结合了许多高科技产品所设计出来的休闲用品，所以商品的使用不当或不熟悉都可能会造成严重伤害甚至死亡，使用之前请务必详读说明书，勿轻忽并注意自身安全！任何遥控直升机的使用，制造商和经销商是无法对使用者于零件使用的损耗异常或组装不当所发生之意外负任何责任，本产品是为提供有操作过模型直升机经验的成人或有相当技术的人员在旁指导，以确保安全无虞下操作使用，产品售出后本公司将不负任何操作和使用控制上的任何性能与安全责任。

NOTE 声明

Fly only in safe areas, away from other people. Do not operate R/C helicopter within the vicinity of homes or crowds of people. R/C helicopter is prone to accidents, failures, and crashes due to a variety of reasons including, lack of maintenance, pilot error, and radio interference. Pilots are liable for their actions and damage or injury occurring during the operation or as a result of R/C helicopter models.

2. SAFETY NOTES 安全注意事项

• LOCATE AN APPROPRIATE LOCATION 远离障碍物及人群

R/C helicopters fly at high speed, thus posing a certain degree of potential danger. Choose an appropriate flying site consisting of flat, smooth ground, a clear open field, or a large open room, such as gymnasium or warehouse without obstacles. Do not fly near buildings, high voltage cables, or trees to ensure the safety of yourself, others and your model. Do not play your model in inclement weather, such as rain, wind, snow or darkness.

直升机飞行时具有一定的速度，相对的也潜在着一定危险性，场地的选择也相对的重要，请需遵守法规到合法遥控飞行场地飞行。必须注意周围有没有人、高楼、建筑物、高压电线、树木等等，避免操控的不当造成自己与他人财产的损坏。初次练习时，务必选择在空旷合法专属飞行场地并适当搭配练习架飞行，这对飞行失误造成的损伤将会大幅的降低。请勿在下雨、打雷等恶劣天气下操作，以确保本身及机体的安全。



• OBTAIN THE ASSISTANCE OF AN EXPERIENCED PILOT 避免独自操控

Before turning on your model and transmitter, check to make sure no one else is operating on the same frequency. Frequency interference can cause your model, or other models to crash. The guidance provided by an experienced pilot will be invaluable for the assembly, tuning, trimming, and actual first flight (recommend you to practice with computer-based flight simulator).



至飞行场飞行前，需确认是否有相同频率的同好正在进行飞行，因为开启相同频率的发射机将导致自己与他人立即干扰等意外危险。遥控飞机操控技巧在学习初期有着一定的难度，要尽量避免独自操作飞行，需有经验的人士在旁指导，才可以操控飞行。（勤练电脑模拟器及老手指导是入门必要的选择）。

● ALWAYS BE AWARE OF THE ROTATING BLADES 远离运转中零件

During the operation of the helicopter, the main rotor will be spinning at a high rate of speed. The blades are capable of inflicting serious bodily injury and damage the environment. Be conscious of your actions, and careful to keep your face, eyes, hands, and loose clothing away from the blades. Always fly the model a safe distance from yourself and others, as well as surrounding objects. Never take your eyes off the model or leave it unattended while it is turned on. Immediately turn off the model and transmitter when you have landed the model.



当直升机主旋翼与尾旋翼运转时，切勿触摸并远离任何物件，以避免造成危险及损坏。

● PREVENT MOISTURE 远离潮湿环境

R/C models are composed of many precision electrical components. It is critical to keep the model and associated equipment away from moisture and other contaminants. The introduction or exposure to water or moisture in any form can cause the model to malfunction resulting in loss of use, or a crash. Do not operate or expose to rain or moisture.



直升机内部也是由许多精密的电子零组件组成，所以必须绝对的防止潮湿或水气，避免在浴室或雨天时使用，防止水气进入机身内部而导致机件及电子零件故障而引发不可预期的意外！

● KEEP AWAY FROM HEAT 远离热源

R/C models are made up of various forms of plastic. Plastic is very susceptible to damage or deformation due to extreme heat and cold climate. Make sure not to store the model near any source of heat such as an oven, or heater. It is best to store the model indoors, in a climate-controlled, room temperature environment.



遥控飞机多半是以PA维修或聚乙烯、电子商品为主要材质，因此要尽量远离热源、日晒以避免因高温而变形甚至熔毁损坏的可能。

● PROPER OPERATION 勿不当使用本产品

Please use the replacement of parts on the manual to ensure the safety of instructors. This product is for R/C model, so do not use for other purpose.

请勿自行改造加工，任何的升级改装或维修，请使用KDS产品目录中的零件，以确保结构的安全。请确认于产品限界内操作，请勿过载使用，并勿用于安全、法令外其它非法用途。



● SAFE OPERATION 安全操作

Operate this unit within your ability. Do not fly under tired condition or improper operation, which may cause danger.

请于自己能力内及需要一定技术范围内操作这台直升机，过于疲劳、精神不佳或不当操作，意外发风险将可能会提高。



3.SAFETY CHECK BEFORE FLYING 飞行前安全检查重要事项

Before flying, please check to make sure no one else is operating on the same frequency for the safety.

Before flying, please check if the power of transmitter and helicopter are enough for the flight.

Before turn on the transmitter, please check if the throttle stick is in the lowest position, IDLE switch is OFF.

When turn off the unit, please follow the power on/off procedure. Power ON-Please turn on the transmitter first, and then turn on helicopter power. Power OFF-Please turn off the helicopter power first and then turn off the transmitter. Improper procedure may cause out of control, so please to have this correct habit.

Before operation, check every movement is smooth and directions are correct. Inspect servos carefully for interference and broken gear.

Check for missing or loose screws and nuts. See if there is any cracked and incomplete assembly of parts.

Check main rotor blades and rotor holders carefully. Broken and premature failures of parts possibly result in a dangerous situation.

Check all ball links to avoid excess play and replace as needed. Failure to do so will result in poor flight stability.

Check the battery and power plug are fastened. Vibration and violent flight may cause the plug loose and lead to out of control.

Check for the tension of tail drive belt.

每次飞行前应先确认所使用的频率是否会干扰他人，以确保你自身与他人的安全。

每次飞行前确定你发射机与直升机电源的电量是在足够飞行的状态。

开机前确认油门摇杆是否位于最低点，熄火降落开关，定速开关（IDLE）是否于关闭位置。

关机时必须遵守电源开关机的程序，开机时应先开启发射机后，再开启直升机电源：关机时应先关闭直升机电源，再关闭发射机电源。不正确的开关机程序可能会造失控的现象，影响自身与他人的安全，请养成正确的习惯。

开机请先确定直升机的各个动作是否顺畅，及方向是否正确，并检查伺服的动作是否有干涉或崩齿的情形，使用故障的伺服器将导致不可预期的危险。

飞行前确认没有缺少或松脱的螺丝与螺帽，确认没有组装不完整或损毁的零件，仔细检查主旋翼是否有损坏，特别是接近主旋翼夹座的部位。

损坏或组装不完整的零件不仅影响飞行，更会造成不可预期的危险。注意：对损耗、有裂痕零件更新及定期保养检查得要性。

检查所有的连杆头是否有松脱的情形，过松的连杆头应先更新，否则将造成直升机无法操控的危险。

确认电池及电源接头是否固定牢靠，飞行中的震动或激烈的飞行，可以造成接头松脱而造成失控的危险。

When you see the marks as below, please use glue or grease to ensure flying safety.

标有下符号之组装步骤，请配合上胶或上油，以确保使用之可靠度。

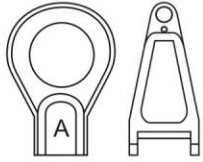

- 502 : Apply CA glue to fix.
- 509 : Apply anaerobics retainer to fix.
- 340 : Apply thread lock to fix.
- OIL : Add grease.
- 502 : 使用瞬间胶固定
- 609 : 使用金属管状固定缺氧胶固定
- 340 : 使用螺丝缺氧胶固定
- OIL : 添加润滑油

When assembling ball links, make sure the "A" character faces outside.

各项塑胶制连杆头扣接时，A字请朝外。



Red
红色



Green
绿色

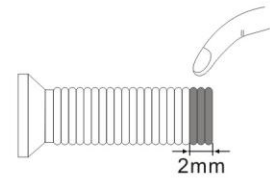

340 Glue width: approx. 1mm
340上胶宽度约1mm

609 Lubrication grease. 340 thread lock, apply a small amount on screws or metal parts and wipe surplus off. When disassembling, recommend to heat the metal joint about 15 seconds. (NOTE: Keep plastic parts away from heat.)

609 为滑润脂，340为螺丝胶，胶合螺丝或金属内外径请务必少量使用，必要时请用手去除胶量，欲拆卸时可以金属接合部位热烤约15秒。（注意！塑胶件避免接近热源）

4.ASSEMBLY PROCESS OF MAIN ROTOR HEAD

主旋转头组装步骤(1)

Dosage form of spare parts 零件用量表

No.序号	Part No. 配件编号	Description 名称	Quantity 数量	Specification 规格
001	550-3TS	Ball-bearing 滚珠轴承	4	Φ8*Φ16*5
002	550-3TS	Metal main rotor holder 主翼夹头	2	
003	550-3TS	Washer 垫片	2	Φ12*Φ15.8*0.5
004	550-3TS	Thrust bearing 止推轴承	2	F8-16M
005	550-58TTS	Linkage ball A 球头A	4	Φ5*8.5
006	550-6TS	Bell control arm set 贝尔控制臂	2	

No.序号	Part No. 配件编号	Description 名称	Quantity 数量	Specification 规格
007	550-6TS	Alu collar 铝套	2	Φ3*Φ4*1.1
008	550-6TS	Ball-bearing 滚珠轴承	4	Φ3*Φ6*2.5
009	550-6TS	Socket screw 圆柱头内六角螺丝	2	M3*10
010	550-6TS	Washer 台阶垫片	2	Φ3*Φ5.5*0.5
011	550-5TS	Main rotor branch control arm 主翼支臂	2	
012	550-5TS	Socket screw 圆柱头内六角螺丝	4	M2.5*6

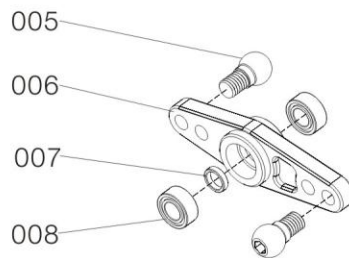
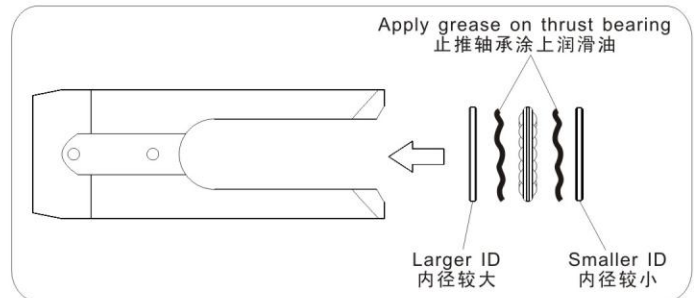
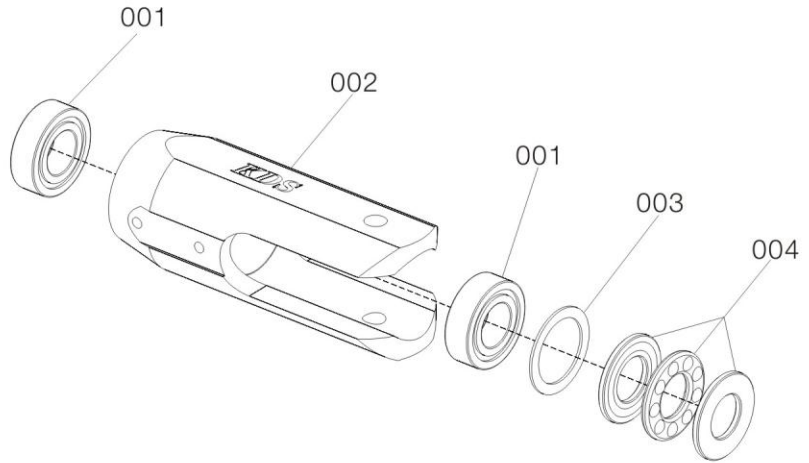
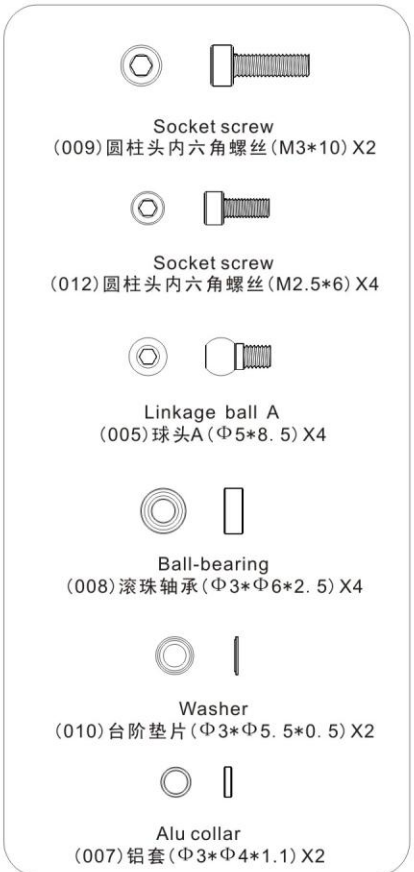
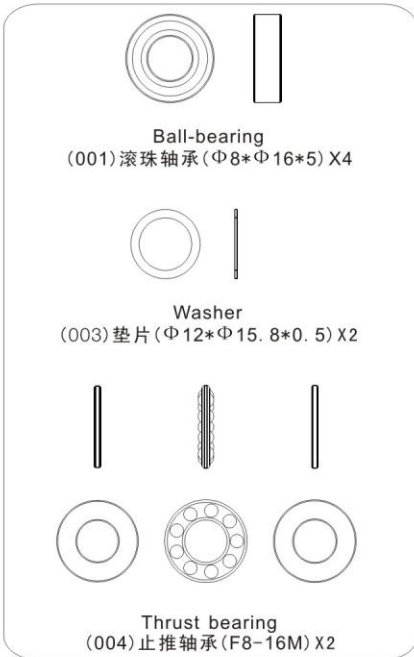

Apply a little amount of 340 thread lock when fixing a metal part.
螺丝锁入金属件请使用适量螺丝胶。

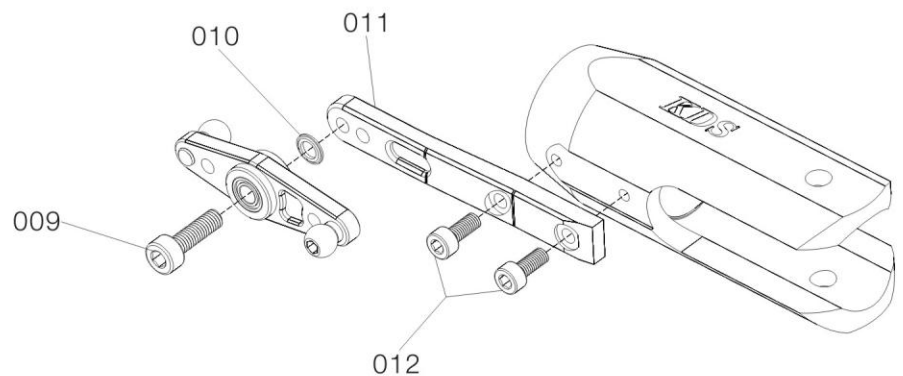

4.ASSEMBLY PROCESS OF MAIN ROTOR HEAD

主旋转头组装步骤(2)

Dosage form of spare parts 零件用量表

No.序号	Part No. 配件编号	Description 名称	Quantity 数量	Specification 规格
013	550-8TTS	Socket screw 圆柱头内六角螺丝	5	M3*6
014	550-8TTS	Braking plate 刹车碟	1	
015	550-7TS	Metal main rotor housing 金属主旋翼固定座	1	
016	550-7TS	Holder bolt 固定座插销	2	Φ2*31
017	550-36TS	Feathering shaft sleeve 横轴套管	1	

No.序号	Part No. 配件编号	Description 名称	Quantity 数量	Specification 规格
018	550-37TS	Feathering shaft 横轴	1	Φ8*94.8
019	550-35TS	Damper rubber 横轴胶圈	2	Φ7.9*Φ13*6.5
020	550-57	Washer 垫片	2	Φ8*Φ15*1
021	550-37TS	Washer 垫片	2	Φ5*Φ13*1.2
022	550-37TS	Socket screw 圆柱头内六角螺丝	2	M5*12

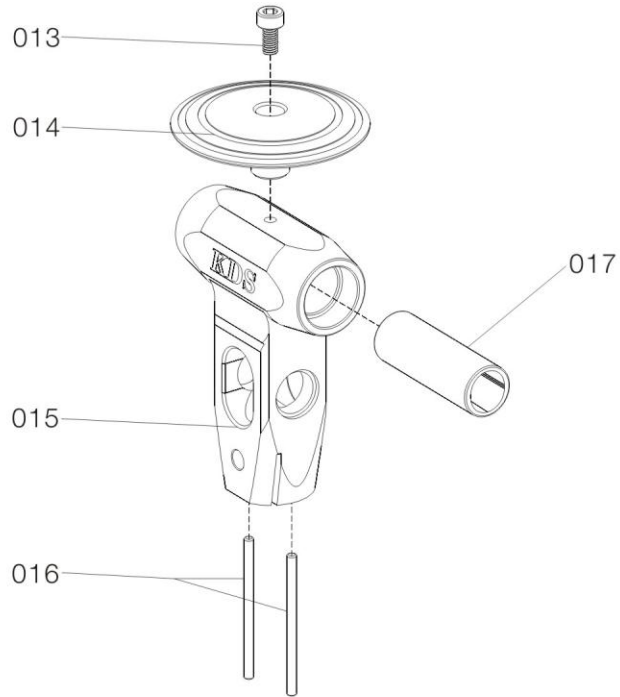
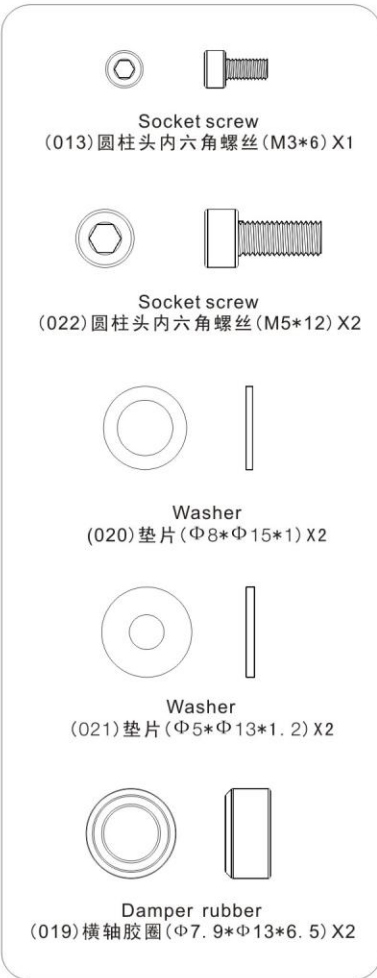

Apply a little amount of 340 thread lock when fixing a metal part.
螺丝锁入金属件请使用适量螺丝胶。

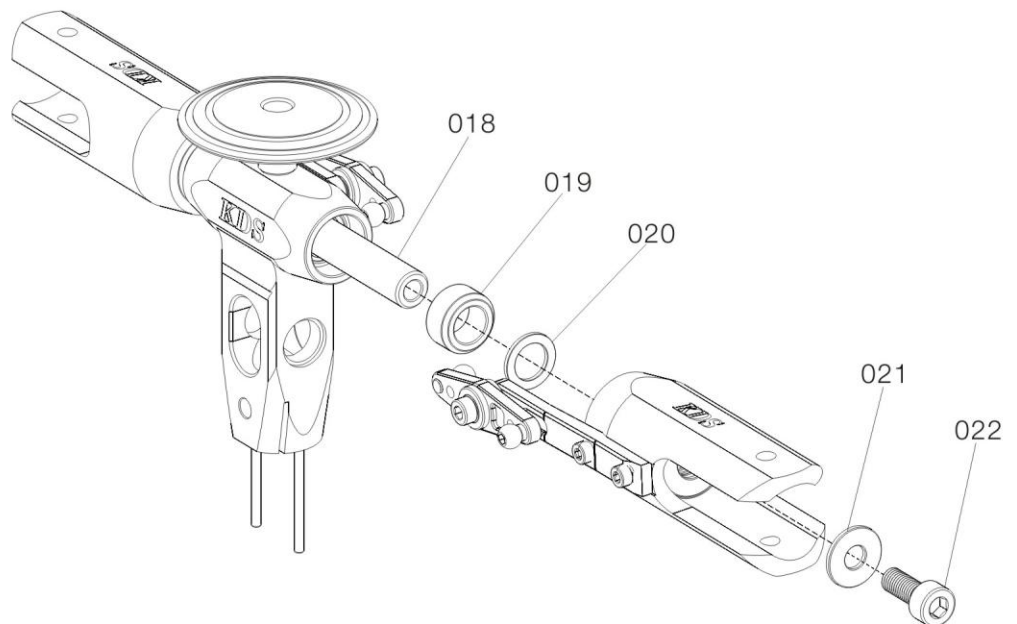

4.ASSEMBLY PROCESS OF MAIN ROTOR HEAD

主旋转头组装步骤(3)

Dosage form of spare parts 零件用量表

No.序号	Part No. 配件编号	Description 名称	Quantity 数量	Specification 规格
023	550-10TS	Metal flybar seesaw holder 金属平衡杆固定座	1	
024	550-10TS	Ball-bearing 滚珠轴承	2	Φ3*Φ7*3
025	550-7TS	Flange bearing 法兰轴承	2	Φ4*Φ9*4
026	550-10TS	M3 Collar screw 台阶螺丝	2	M3*7.7
027	550-9TS	Flybar control rod 平衡翼球型控制杆	2	

No.序号	Part No. 配件编号	Description 名称	Quantity 数量	Specification 规格
028	550-9TS	KIMI screw 基米螺丝	2	M4*4
029	550-9TS	Metal flybar control arm 金属平衡翼控制臂	2	
030	550-53	Linkage rod (A) 连杆(A)	2	Φ2.2*18
031	550-54TS	Ball link 拉杆头	4	
032	550-58TTS	Linkage ball B 球头B	2	Φ5*10.7
033	550-11TTS	Flybar rod 平衡杆	1	Φ3*420

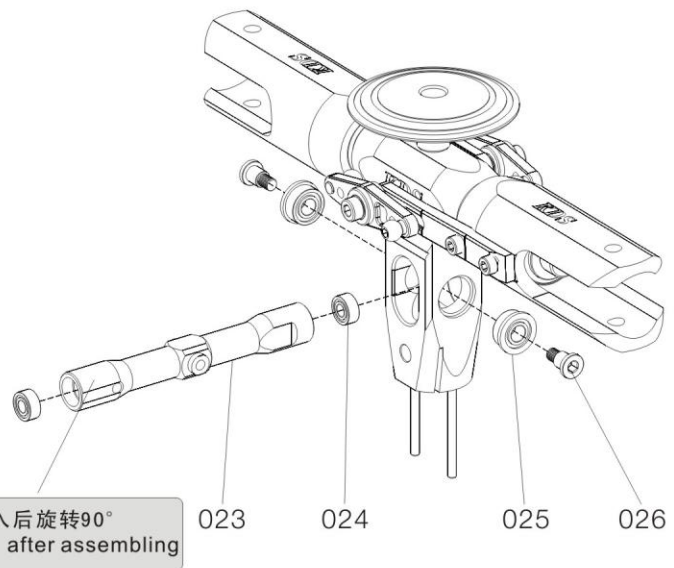
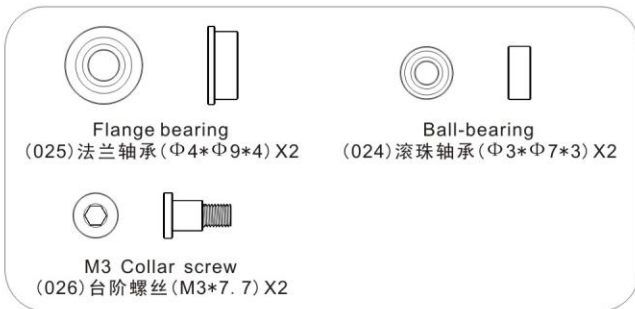

Apply a little amount of 340 thread lock when fixing a metal part.
螺丝锁入金属件请使用适量螺丝胶。

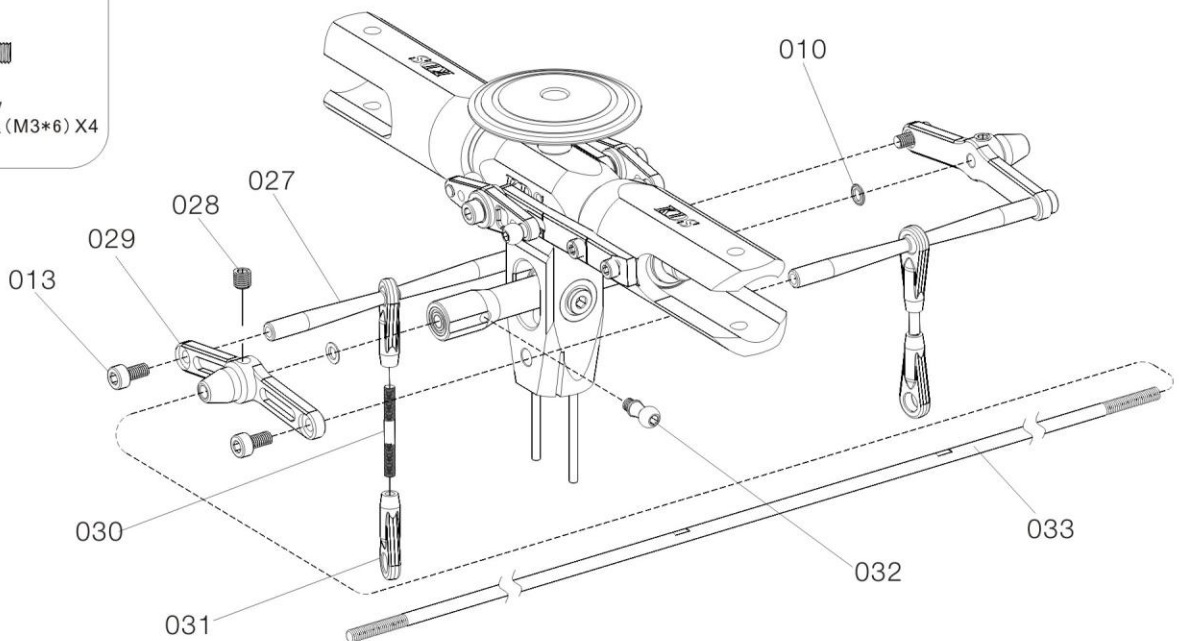

5.ASSEMBLY PROCESS OF MAIN FRAME AND POWER SYSTEM

主体侧板与动力系统组装步骤(1)

Dosage form of spare parts 零件用量表

No.序号	Part No. 配件编号	Description 名称	Quantity 数量	Specification 规格
034	550-34	Pulley Pin 皮带轮压轮销	2	Φ3*14.8
035	550-34	Belt wheel 皮带压轮	2	
036	550-34	Belt wheel holder 皮带压轮座	2	
037	550-23TTS	Anti-rotation bracket 十字盘导板	1	
038	550-23TTS	M2 Nut 螺母	2	M2
039	550-22	Rear strengthening plate(right) 后右加强块	1	
040	550-17	Ball-bearing 滚珠轴承	2	Φ10*Φ19*5
041	550-17	Main shaft mounting holder 主轴固定座A	1	
042	550-22	Front strengthening plate(right) 前右加强块	1	
043	550-17	Main shaft mounting holder 主轴固定座B	1	

No.序号	Part No. 配件编号	Description 名称	Quantity 数量	Specification 规格
044	550-41	Main frame 碳纤维侧板	2	
045	550-43	Mounting plate of ESC ESC固定板	1	
046	550-42	Mounting plate of battery 电池固定板	1	
047	550-45	Frame mounting bolt 机身铝固定柱	3	Φ5*55
048	550-45	Landing skid mount 脚架固定座	2	
049	550-23TTS	Socket screw 圆柱头内六角螺丝	2	M2*8
050	550-44	Receiver mounting plate 接收机固定板	1	
051	550-20	Tail boom stiffener 尾管固定座	2	
052	550-56	M3 Locknut 防松螺母	2	M3
053	550-56	Socket screw 圆柱头内六角螺丝	24	M2.5*8
054	550-79TTS	Canopy mounting bolt holder 机壳铝柱固定板	2	

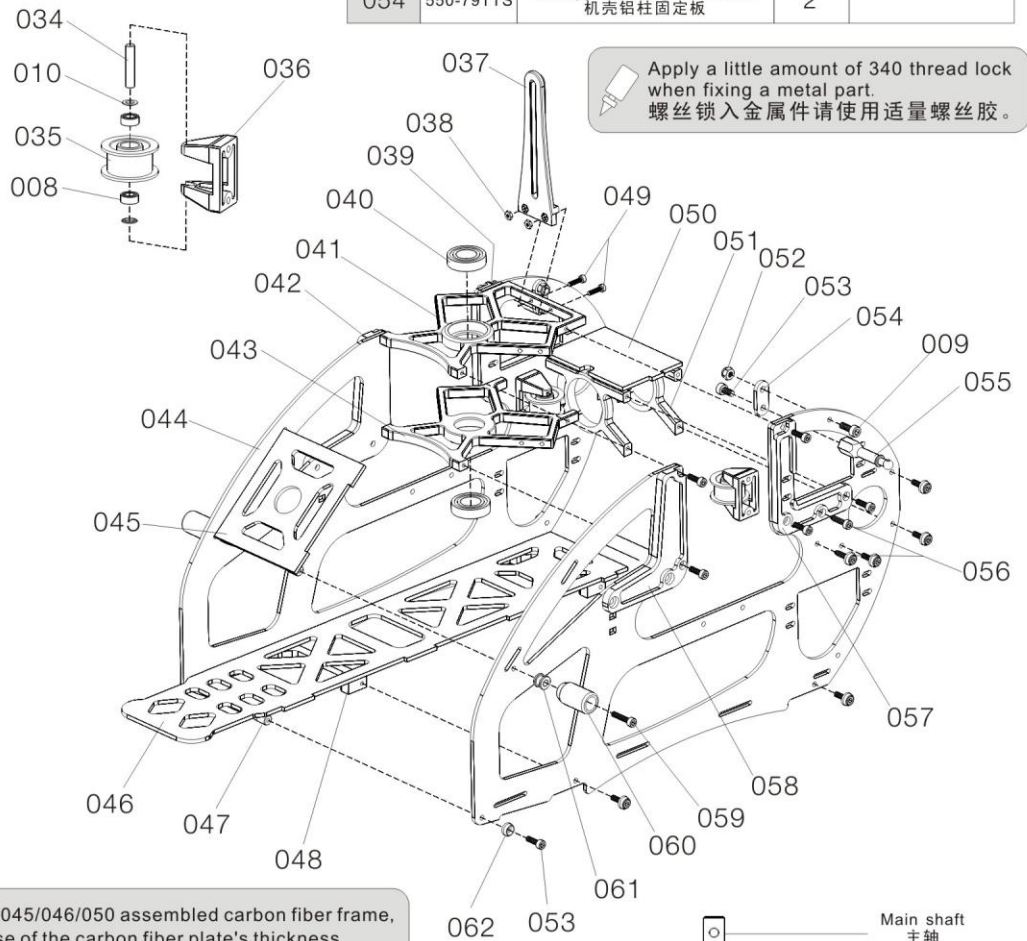
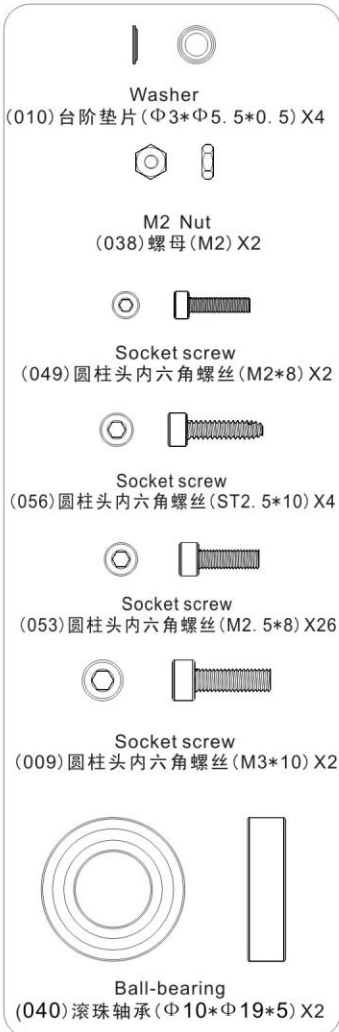

Main frame assembly key point:

First do not fully tighten the screws of main frames and put two bearings through the main shaft to check if the movements are smooth. The bottom bracket must be firmly touched the level table top (glass surface) Please keep the smooth movements on main shaft and level bottom bracket, then tighten the screws slowly. This assembly can help for the power and flight performance.

机身侧板组装重点:

侧板螺丝不完全锁紧, 放入主轴贯穿二颗轴承确认上下移动必须滑顺, 主体底板必须与水平旧面(玻璃平面)踏实紧贴, 请保持主轴滑顺与底板平行旧面后慢慢锁紧螺丝。正确侧板的组装对动力与飞行性能有明显帮助。

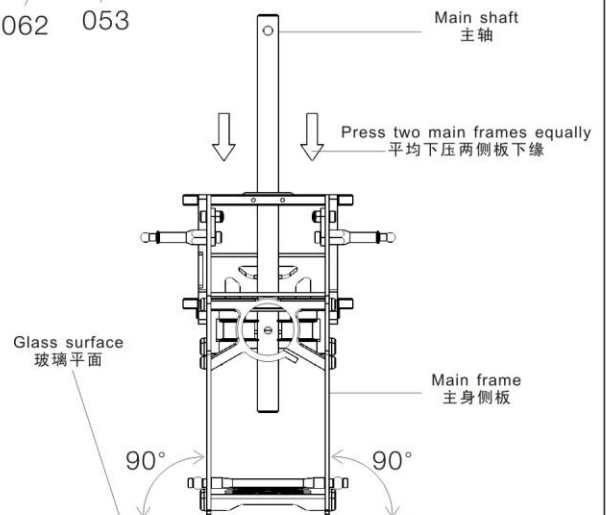

5.ASSEMBLY PROCESS OF MAIN FRAME AND POWER SYSTEM

主体侧板与动力系统组装步骤(2)

Dosage form of spare parts 零件用量表

No.序号	Part No. 配件编号	Description 名称	Quantity 数量	Specification 规格
055	550-63	Canopy mounting bolt 机壳固定柱	2	
056	550-63	Socket screw 圆柱头内六角螺丝	4	ST2. 5*10
057	550-22	Rear strengthening plate(left) 左后加强块	1	
058	550-22	Front strengthening plate(left) 左前加强块	1	
059	550-56	Socket screw 圆柱头内六角螺丝	2	M2. 5*12
060	550-83TTS	Canopy spacer 机头罩支撑垫圈	2	
061	550-83TTS	canopy spacer holder 机头罩支撑垫圈座	2	
062	550-55	Washer 螺丝铝垫	20	

No.序号	Part No. 配件编号	Description 名称	Quantity 数量	Specification 规格
063	550-68	Landing skid 脚架	2	
064	550-56	KIMI screw 基米螺丝	4	
065	550-69TTS	Landing skid nut 脚架垫圈	4	
066	550-67	Landing skid stopper 脚架管塞	4	
067	550-67	Skid pipe 脚架铝管	2	
068	550-67	Socket screw 圆柱头内六角螺丝	4	M2. 5*10

Apply a little amount of 340 thread lock when fixing a metal part.
螺丝锁入金属件请使用适量螺丝胶。



Socket screw
(068)圆柱头内六角螺丝(M2. 5*10) X4



KIMI screw
(064)基米螺丝(M3*3) X4

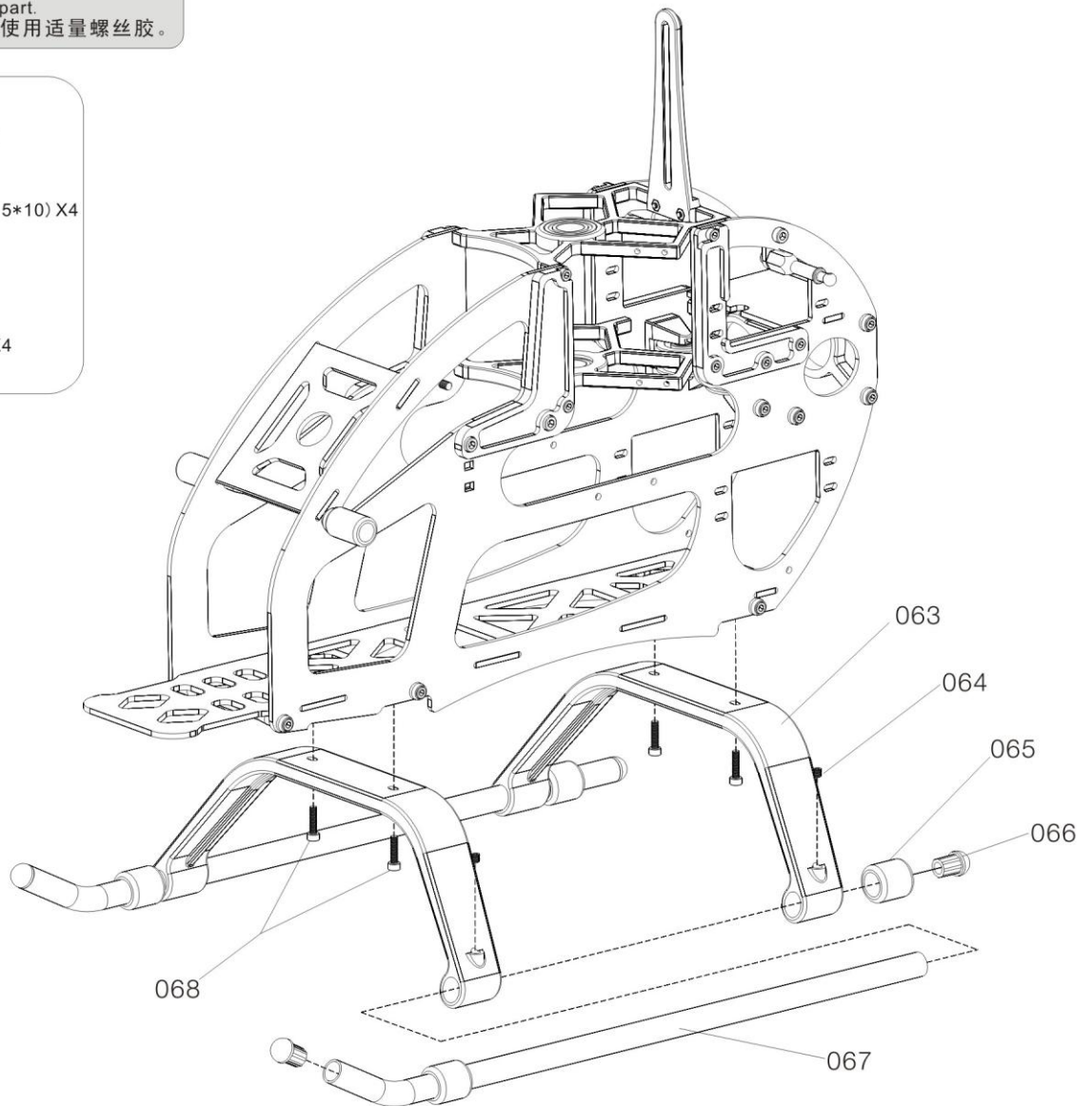

5.ASSEMBLY PROCESS OF MAIN FRAME AND POWER SYSTEM

主体侧板与动力系统组装步骤(3)

Dosage form of spare parts 零件用量表

No.序号	Part No. 配件编号	Description 名称	Quantity 数量	Specification 规格
069		Motor 马达	1	Kv1200
070	550-71	Motor pinion 马达齿轮	1	14T
071	550-21	Motor mount 马达固定座	1	
072	550-21	Socket screw 圆柱头内六角螺丝	2	M4*10
073	550-21	Socket screw 圆柱头内六角螺丝	4	M3*8

No.序号	Part No. 配件编号	Description 名称	Quantity 数量	Specification 规格
074	550-58TTS	Linkage ball C 球头C	2	Φ5*8.5
075	2004-11	Servo horn 伺服器舵角片	2	
076	550-64TTS	Servo plate 伺服器压片	4	
077	2004-11	Servo 伺服器	2	680
078	550-65	Servo mount 伺服器固定座	2	

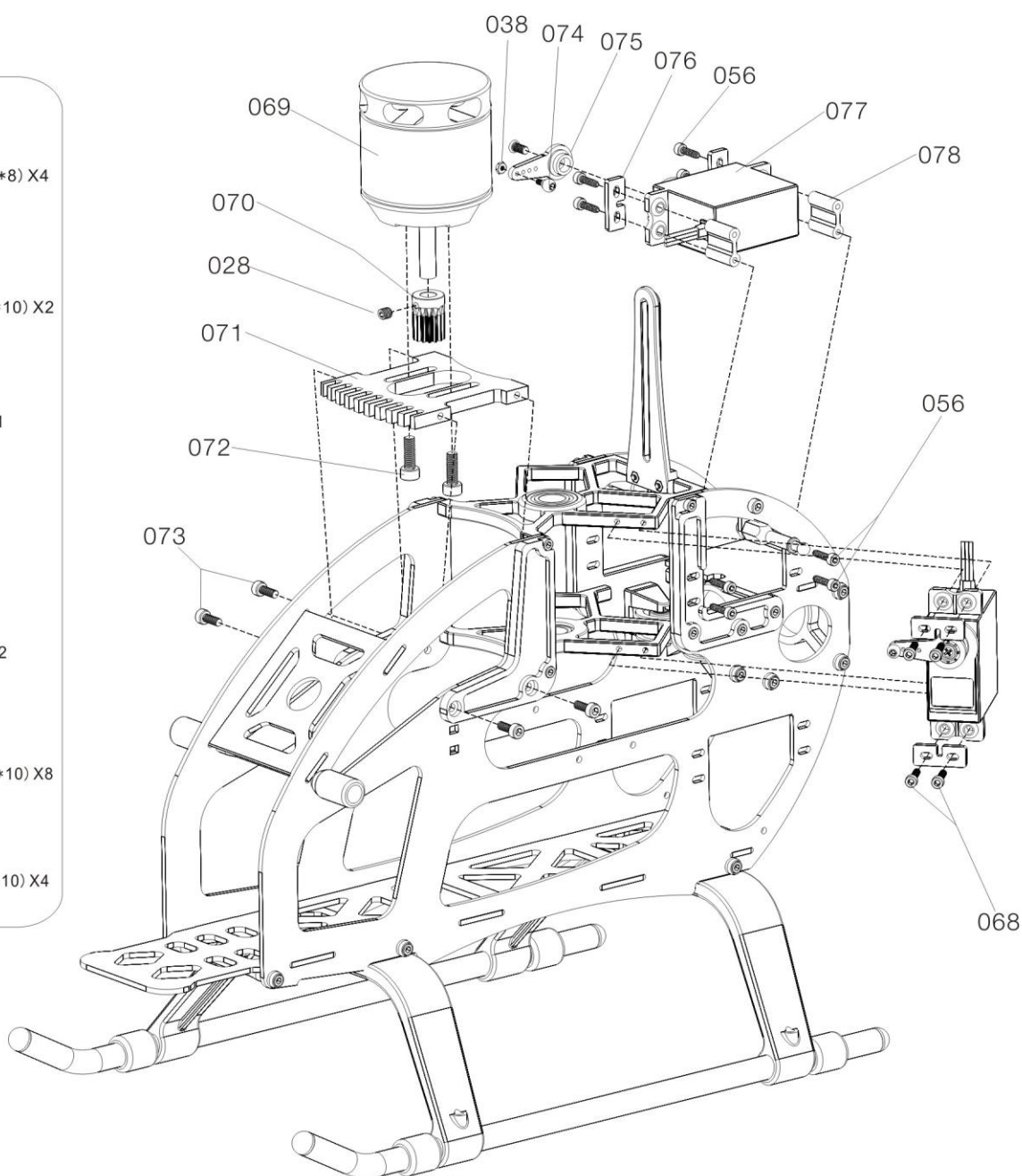

Apply a little amount of 340 thread lock when fixing a metal part.
螺丝锁入金属件请使用适量螺丝胶。

5.ASSEMBLY PROCESS OF MAIN FRAME AND POWER SYSTEM

主体侧板与动力系统组装步骤(4)

Dosage form of spare parts 零件用量表

No.序号	Part No.配件编号	Description名称	Quantity数量	Specification规格
079	2004-7	Servo 伺服器	1	690



M2 Nut
(038) 螺母(M2) X2



Socket screw
(056) 圆柱头内六角螺丝(ST2. 5*10) X8



Linkage ball C
(074) 球头C(Φ5*8. 5) X2



Socket screw
(068) 圆柱头内六角螺丝(M2. 5*10) X4

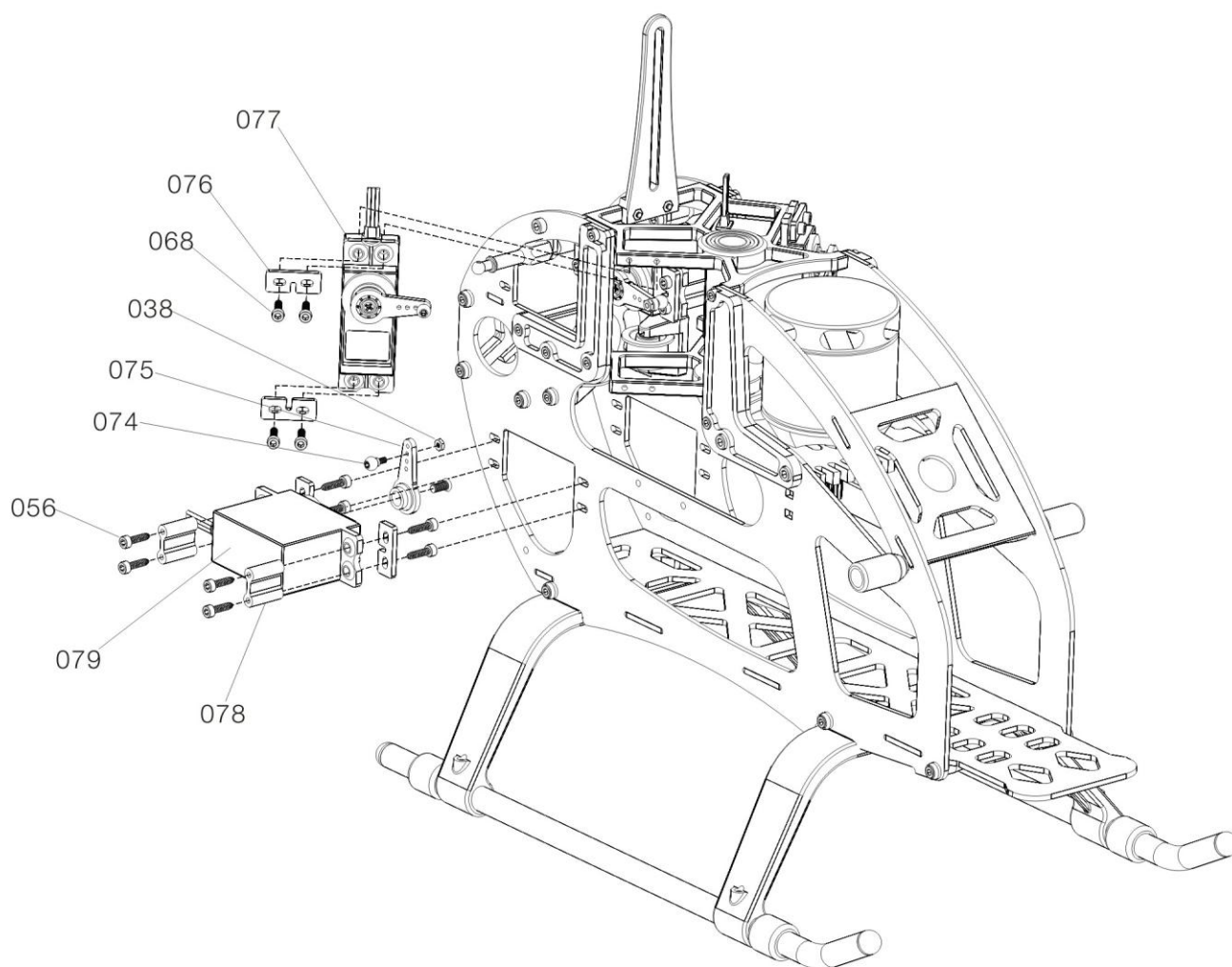

Apply a little amount of 340 thread lock when fixing a metal part.
螺丝锁入金属件请使用适量螺丝胶。

5.ASSEMBLY PROCESS OF MAIN FRAME AND POWER SYSTEM

主体侧板与动力系统组装步骤(5)

Dosage form of spare parts 零件用量表

No.序号	Part No.配件编号	Description名称	Quantity数量	Specification规格
080	550-57	Washer垫片	2	$\Phi 10 * \Phi 14 * 0.5$
081	550-52	Pulley皮带轮	1	
082	550-52	Pulley cover皮带轮盖	1	
083	550-56	Cruciform slotted Screw十字槽平头螺丝	6	ST2*4
084	550-51	Main drive gear主齿轮	1	115T

No.序号	Part No.配件编号	Description名称	Quantity数量	Specification规格
085	550-50	Copper washer铜垫片	2	$\Phi 10 * \Phi 14 * 2$
086	550-50	One way bearing block单向轴承座	1	
087	550-50	One-way Bearing单向轴承	1	$\Phi 10 * \Phi 14 * 12$
088	550-38	Main shaft主轴	1	
089	550-66	Belt皮带	1	672XL

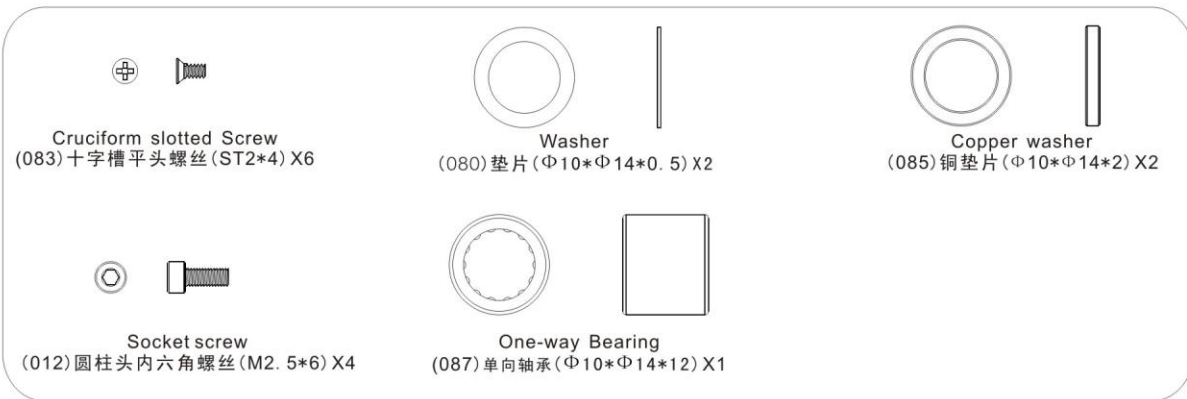

Apply a little amount of 340 thread lock when fixing a metal part.
螺丝锁入金属件请使用适量螺丝胶。

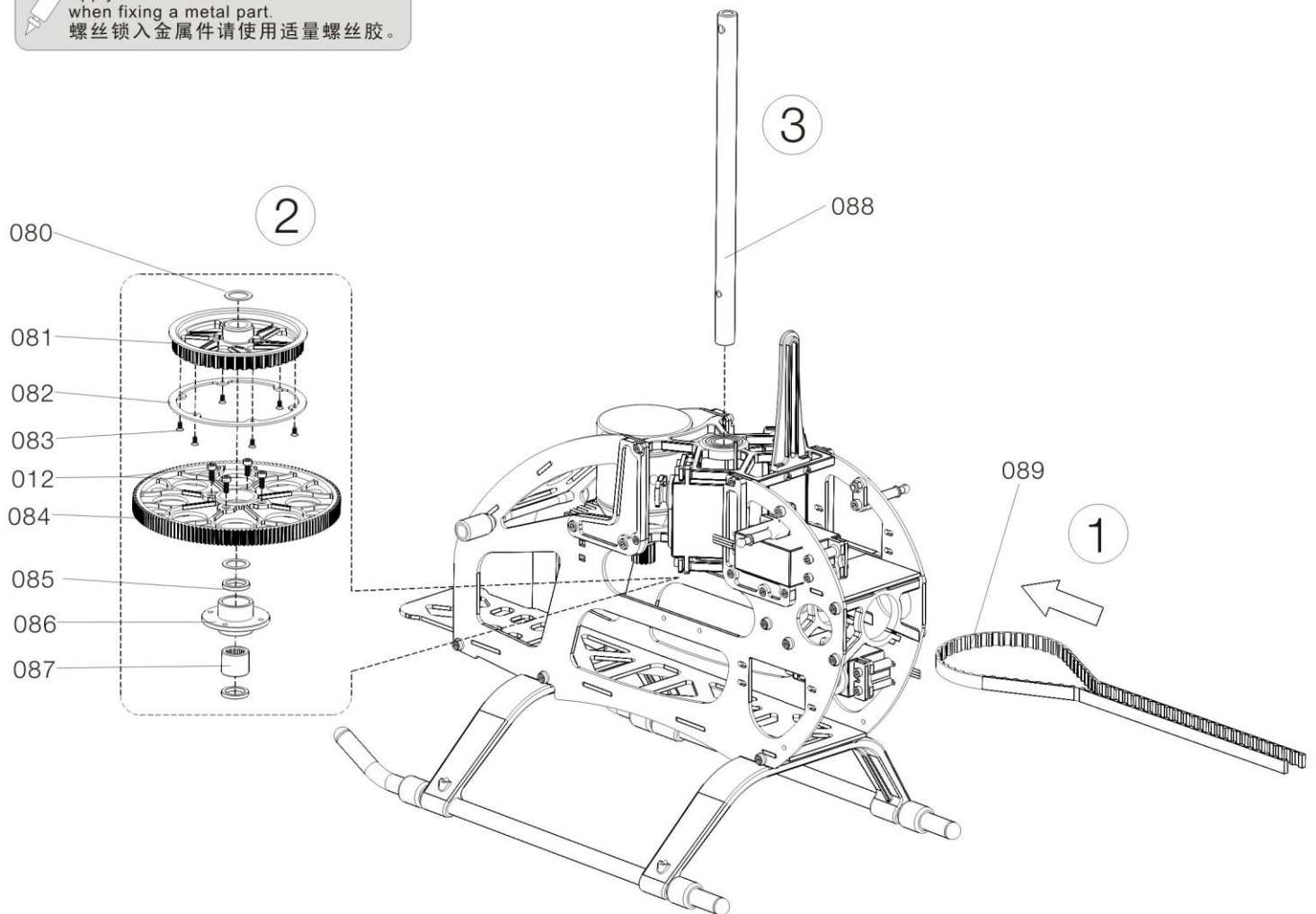

5.ASSEMBLY PROCESS OF MAIN FRAME AND POWER SYSTEM

主体侧板与动力系统组装步骤(6)

Dosage form of spare parts 零件用量表

No.序号	Part No.配件编号	Description名称	Quantity数量	Specification规格
090	550-38	Pulley pin 皮带轮销子	1	Φ3*18
091	550-52	Alu Collar 铝套	1	Φ10*Φ12*4.5
092	550-18	Main shaft bearing block 下主轴承座	1	

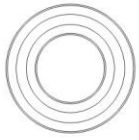

Bearing

(040) 滚珠轴承 (Φ10*Φ19*5) X2



Alu collar

(091) 铝套 (Φ10*Φ12*4.5) X2



Socket screw

(053) 圆柱头内六角螺丝 (M2.5*8) X4

Apply a little amount of 340 thread lock when fixing a metal part.
螺丝锁入金属件请使用适量螺丝胶。

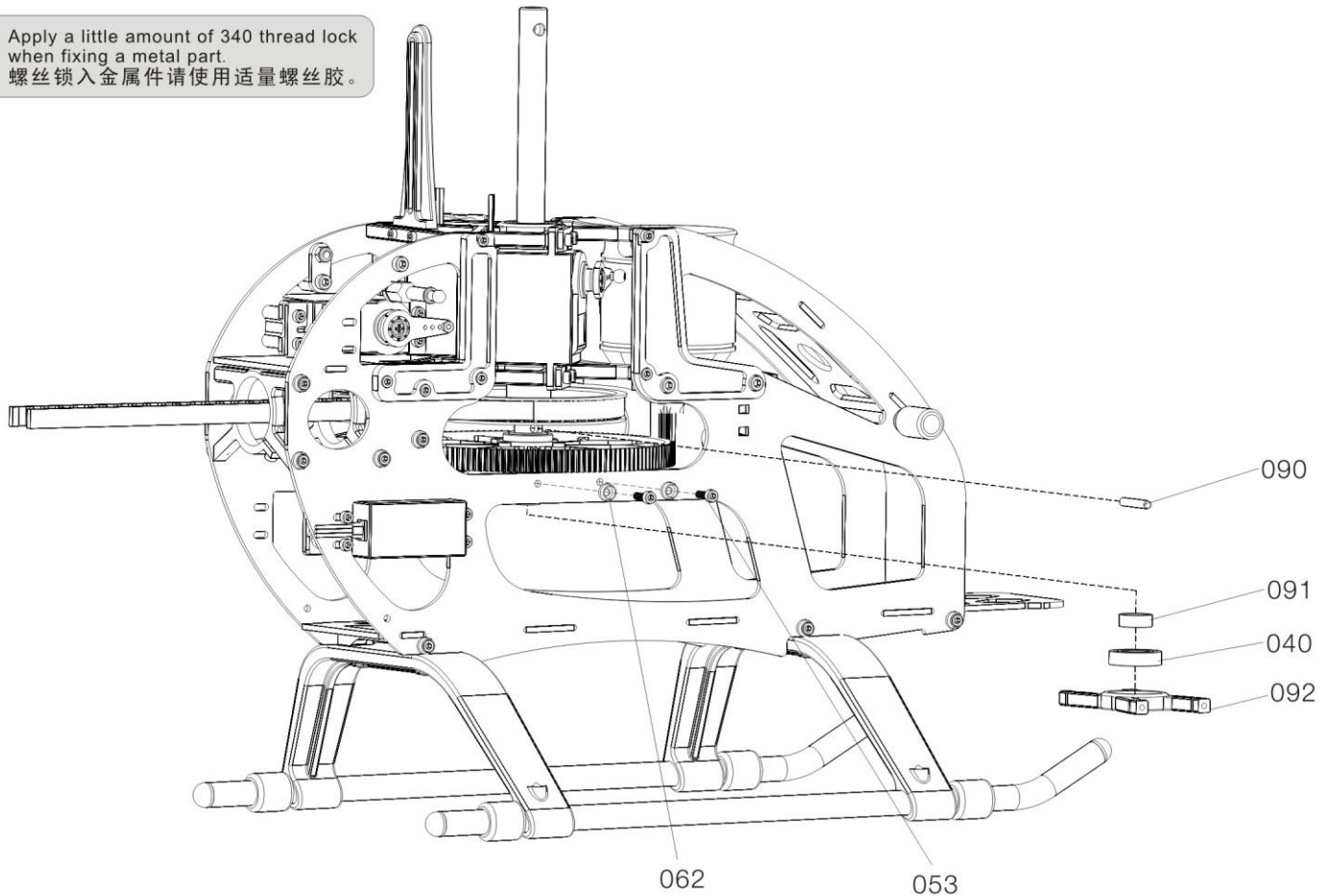

Socket screw

(106) 圆柱头内六角螺丝 (M3*40) X2



Socket screw

(053) 圆柱头内六角螺丝 (M2.5*8) X2



Linkage ball B

(032) 球头B (Φ5*10.7) X6



M2 Nut

(038) 螺母 (M2) X2



Socket screw

(093) 圆柱头内六角螺丝 (M4*20) X1

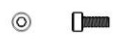

Socket screw

(049) 圆柱头内六角螺丝 (M2*8) X2

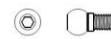

Linkage ball A

(005) 球头A (Φ5*10.7) X2



M3 Nut

(052) 防松螺母 (M3) X2



Socket screw

(096) 圆柱头内六角螺丝 (M3*12) X2



Socket screw

(059) 圆柱头内六角螺丝 (M2.5*12) X2

5.ASSEMBLY PROCESS OF MAIN FRAME AND POWER SYSTEM

主体侧板与动力系统组装步骤 (7)

Dosage form of spare parts 零件用量表

No.序号	Part No. 配件编号	Description 名称	Quantity 数量	Specification 规格
093	550-56	Socket screw 圆柱头内六角螺丝	1	M4*20
094	550-40TS	Lock collar 主轴固定环	1	
095	550-56	M4 Check nut 防松螺母	1	M4
096	550-40TS	Socket screw 圆柱头内六角螺丝	3	M3*12
097	550-12TS	Metal washout base 金属向位器	1	
098	550-13TS	Metal washout control arm 金属稳定控制摇臂	2	
099	550-14TS	Shear type arm 剪型臂	2	
100	550-14TS	Flange bearing 法兰轴承	4	F682ZZ
101	550-14TS	Socket screw 圆柱头内六角螺丝	4	M2*5
102	550-13TS	Alu collar 铝套	2	Φ3*Φ4*1.6

No.序号	Part No. 配件编号	Description 名称	Quantity 数量	Specification 规格
103	550-16TS	Swashplate 倾斜盘	1	
104	550-16TS	Swashplate mounting pin 倾斜盘固定销	1	
105	550-55	Washer 螺丝铝垫	2	
106	550-46TTS	Socket screw 圆柱头内六角螺丝	2	M3*40
107	550-47TTS	Horizontal stabilizer 碳纤维水平翼	1	
108	550-48	Tail boom 尾管	1	Φ25*680
109	550-49TTS	Tail control fixing ring 尾控制杆固定环	2	
110	550-46TTS	Tail unit mount 尾波箱固定座	2	
111	550-60	Tail boom brace alu spacer 尾支撑铝垫	4	
112	550-60	Tail boom brace guide 尾支撑杆接头	4	
113	550-60	Tail boom brace 尾支撑杆	2	Φ5*490

Apply a little amount of 340 thread lock when fixing a metal part.
螺丝锁入金属件请使用适量螺丝胶。

NOTE: Please use long ball head for heli with flybar, and short ball head for heli with flybarless.
注: 有副翼飞机使用长球头, 无副翼飞机使用短球头。

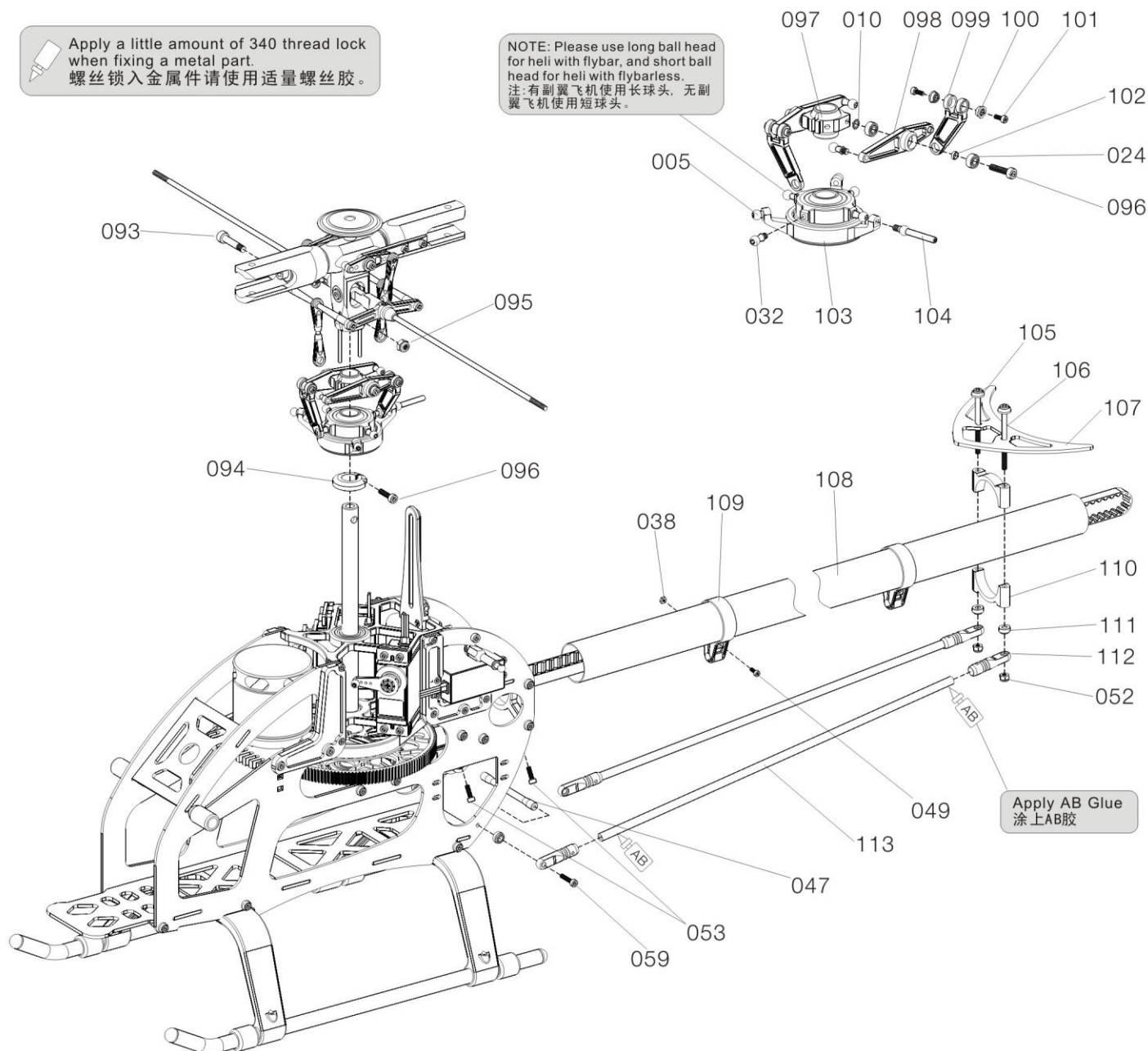

5.ASSEMBLY PROCESS OF MAIN FRAME AND POWER SYSTEM

主体侧板与动力系统组装步骤(8)

Dosage form of spare parts 零件用量表

No.序号	Spare part 配件	Description 名称	Quantity 数量	Specification 规格
114	550-53	Linkage rod (A) 连杆A	2	Φ2.2*76
030	550-53	Linkage rod (B) 连杆B	2	Φ2.2*18
115	550-53	Linkage rod (C) 连杆C	2	Φ2.2*32
116	550-53	Linkage rod (D) 连杆D	1	Φ2.2*54
117	550-54TS	Diplopore linkage rod 双孔连杆	2	
118	1191-550	Flybar paddle 平衡翼	1	

Apply a little amount of 340 thread lock when fixing a metal part.
螺丝锁入金属件请使用适量螺丝胶。

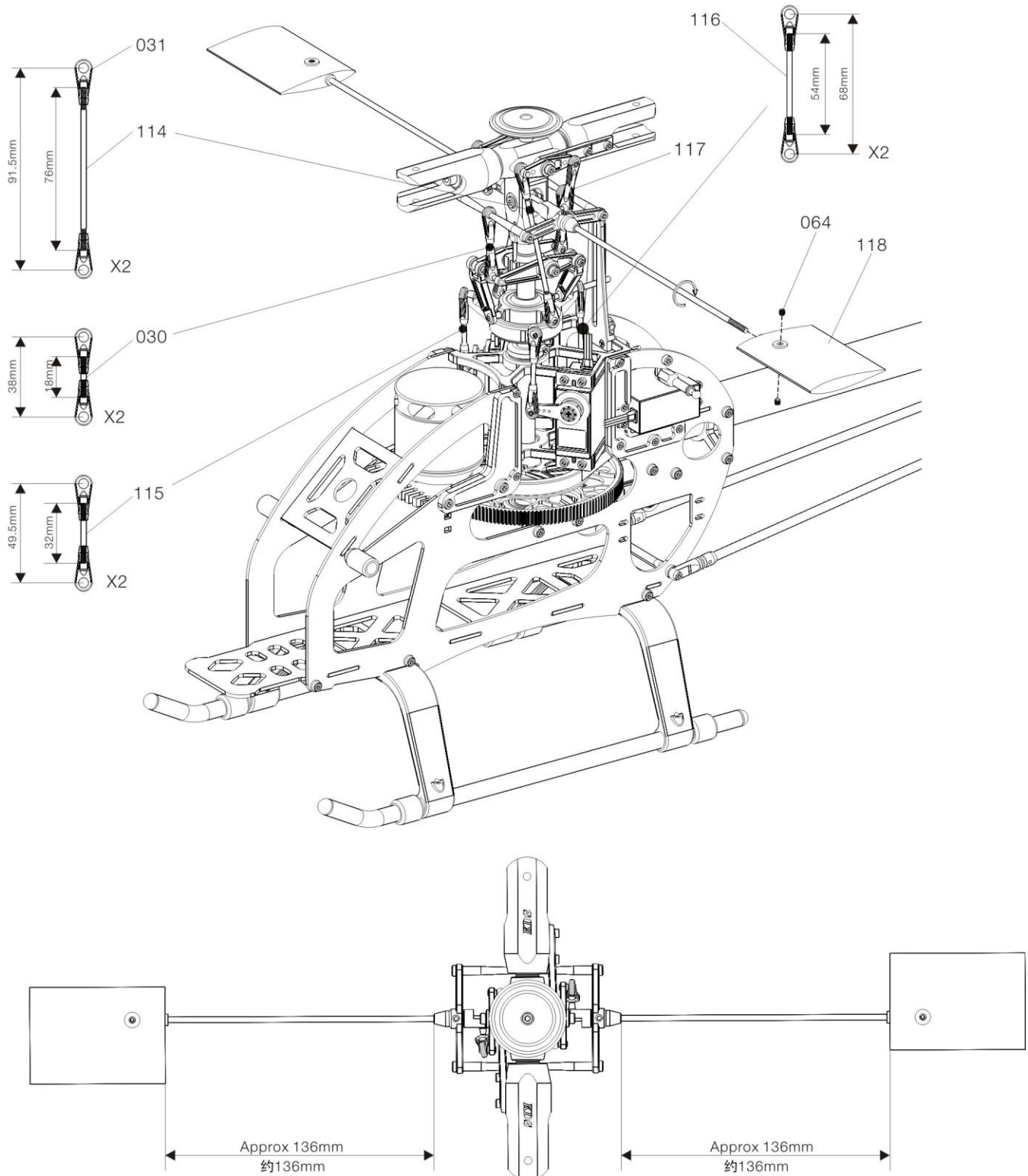

5.ASSEMBLY PROCESS OF MAIN FRAME AND POWER SYSTEM

主体侧板与动力系统组装步骤(9)

Dosage form of spare parts 零件用量表

No.序号	Part No. 配件编号	Description 名称	Quantity 数量	Specification 规格
119	550-56	Socket screw 圆柱头内六角螺丝	1	M3*35
120	550-30TTS	Control arm mount 尾控制臂固定座	1	
121	550-27TTS	Tail shaft 尾轴	1	Φ5*73
122	550-27TTS	Drive belt pulley 皮带带轮	1	
123	550-33TTS	Drive belt pulley bolt 皮带带轮柱	2	
124	550-33TTS	Ball-bearing 滚珠轴承	1	Φ3*Φ8*4
125	550-33TTS	Tail unit mounting bolt 尾齿箱固定铝柱	1	
126	550-27TTS	Pulley pin 尾皮带轮销子	1	

No.序号	Part No. 配件编号	Description 名称	Quantity 数量	Specification 规格
127	550-27TTS	Belt pulley cover 皮带轮盖	1	
128	550-27TTS	Isolated ring of tail pulley 皮带轮隔套	2	
129	550-24TTS	Flange bearing 法兰轴承	2	Φ5*Φ13*4
130	550-32	CF Vertical stabilizer 碳纤维垂直翼	1	
131	550-29TTS	Tail rotor control arm 尾舵控制L臂	1	
132	550-29TTS	Alu collar 尾控制L臂铝套	1	Φ3*Φ4*5.1
133	550-29TTS	Socket screw 圆柱头内六角螺丝	1	M3*14
134	550-24TTS	Metal tail plate 尾齿箱侧板	2	

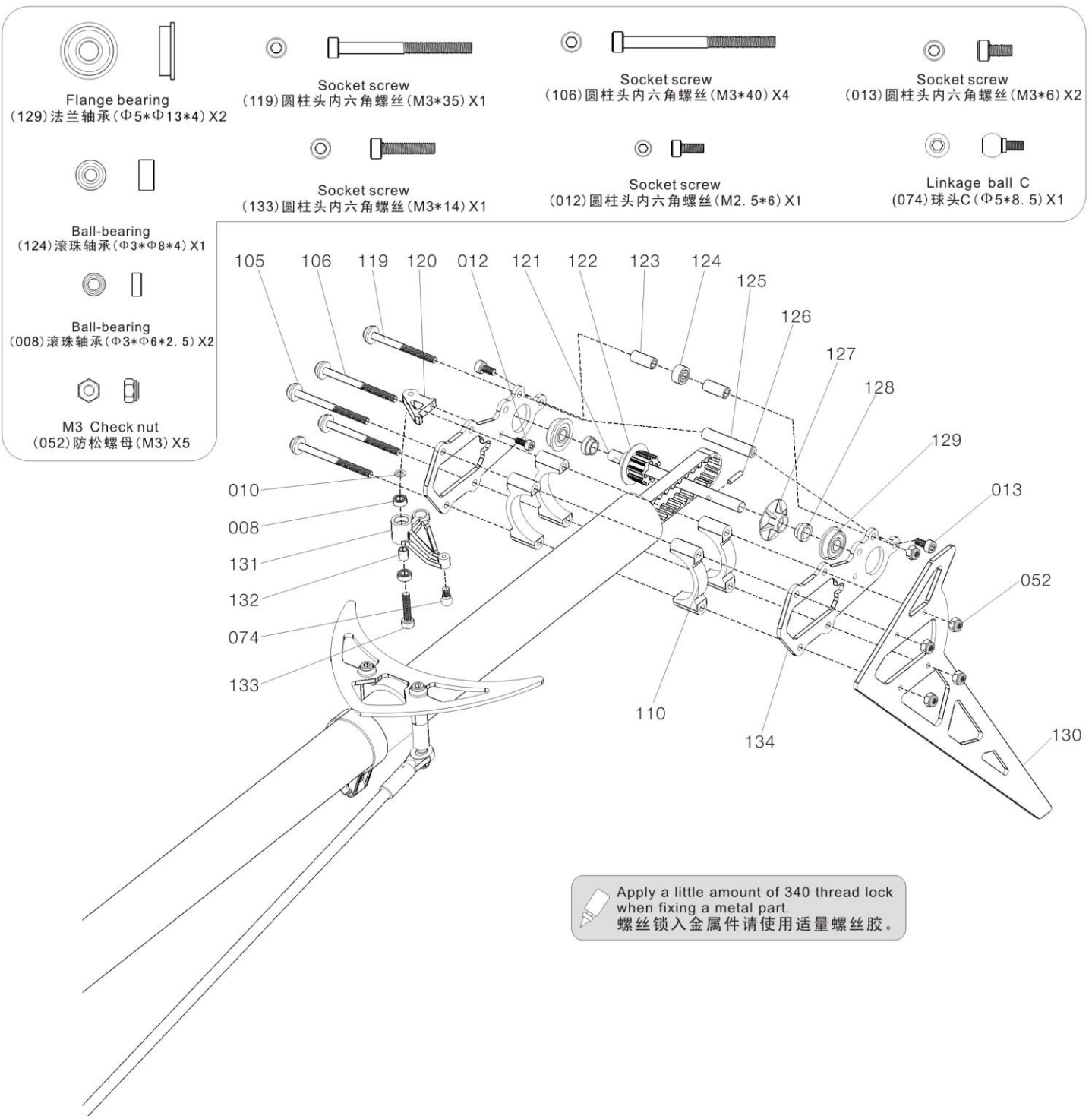

5.ASSEMBLY PROCESS OF MAIN FRAME AND POWER SYSTEM

主体侧板与动力系统组装步骤(10)

Dosage form of spare parts 零件用量表

No.序号	Part No. 配件编号	Description 名称	Quantity 数量	Specification 规格
135	1193-6	CF Tail blade 碳纤维旋翼	1	
136	550-82TTS	Washer 垫片	2	$\Phi 7 * \Phi 9.8 * 0.5$
137	550-82TTS	Socket screw 圆柱头内六角螺丝	2	M3*20
138	550-82TTS	Tail rotor holder 尾旋翼夹座	2	
139	550-82TTS	Ball-bearing 滚珠轴承	4	$\Phi 5 * \Phi 10 * 4$
140	550-82TTS	Tail rotor T type holder 尾旋翼T型座	1	
141	550-28TTS	E-ring E扣	4	
142	550-28TTS	tail blade control bearing sleeve 尾翼控制轴承套	1	
143	550-28TTS	Washer 尾控制套垫圈	1	$\Phi 6 * \Phi 7 * 2$
144	550-28TTS	Tail bearing sleeve 尾轴承套	1	

No.序号	Part No. 配件编号	Description 名称	Quantity 数量	Specification 规格
145	550-28TTS	Ball-bearing 滚珠轴承	2	$\Phi 6 * \Phi 10 * 3$
146	550-28TTS	T type arm 尾T型控制臂	1	
147	550-28TTS	Control link head 尾控制连杆头	2	
148	550-28TTS	Pin 销子	2	$\Phi 2 * 9$
149	550-82TTS	Thrust bearing 止推轴承	2	F5-10M
150	550-57	Washer 垫片	2	$\Phi 3 * \Phi 8 * 0.6$
151	550-56	Socket screw 圆柱头内六角螺丝	2	M4*30
152	1193-9	Main blade 主旋翼	1	550
153	550-62	Tail linkage rod 尾拉杆	1	
154	550-61TTS	Tail boom brace fixture 尾撑杆固定座	2	
155	550-62	Tail linkage rod connecting set 尾拉杆连接件	2	$\Phi 4 * 644$

Apply a little amount of 340 thread lock when fixing a metal part.
螺丝锁入金属件请使用适量螺丝胶。

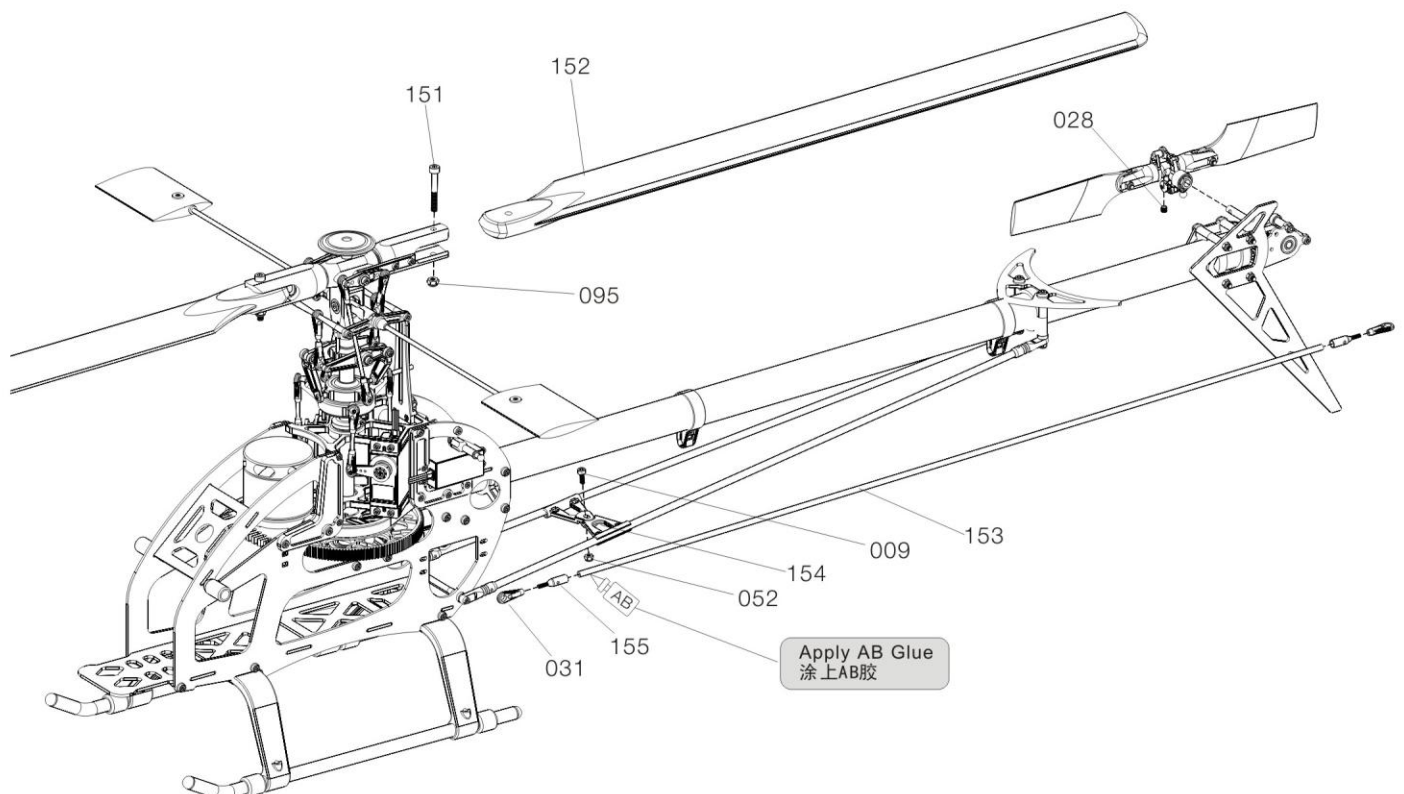
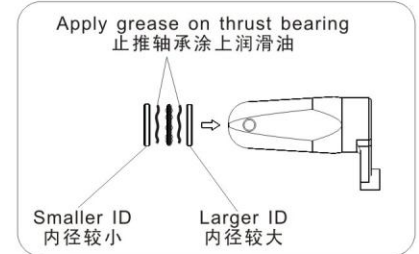
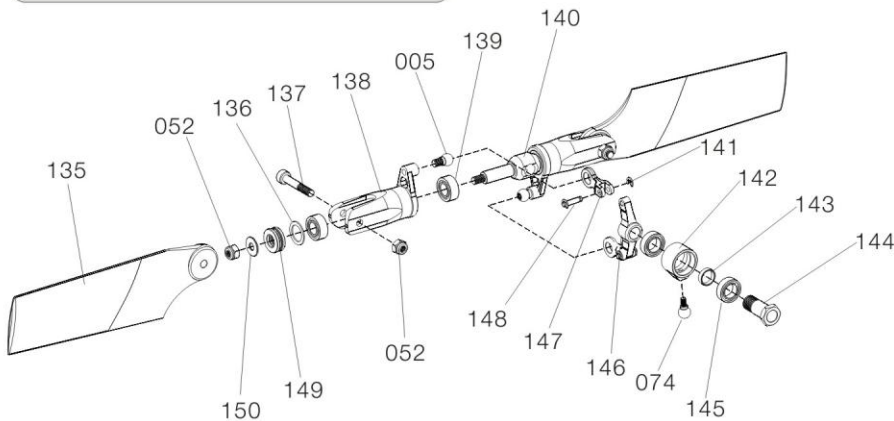

Apply AB Glue
涂上AB胶

6.ASSEMBLY PROCESS OF FLYBARLESS SYSTEM

无副翼系统组装步骤

Dosage form of spare parts 零件用量表

No.序号	Part No.配件编号	Description名称	Quantity数量	Specification规格
095	550-56	M4 Check nut 防松螺母	3	M4
014	550-8TTS	Braking plate 刹车碟	1	
013	550-8TTS	Socket screw 圆柱头内六角螺丝	1	M3*6
156	550-7-TDT-TS	Metal main rotor housing 金属主旋翼固定座	1	
157	550-73TS	Socket screw 圆柱头内六角螺丝	2	M3*16
151	550-56	Socket screw 圆柱头内六角螺丝	2	M4*30
021	550-37TS	Washer 垫片	2	$\Phi 6.7 * \Phi 15 * 1.5$
022	550-37TS	Socket screw 圆柱头内六角螺丝	2	M5*12
158	550-4-TDT-TS	FBL main rotor holder arm 无副翼支臂	2	
012	550-4-TDT-TS	Socket screw 圆柱头内六角螺丝	2	M2.5*6

No.序号	Part No.配件编号	Description名称	Quantity数量	Specification规格
053	550-4-TDT-TS	Socket screw 圆柱头内六角螺丝	2	M2.5*8
010	550-57	Washer 台阶垫片	2	$\Phi 3 * \Phi 5.5 * 0.5$
024	550-73TS	Ball-bearing 滚珠轴承	4	$\Phi 3 * \Phi 7 * 3$
159	550-73TS	Alu collar 铝套	2	$\Phi 3 * \Phi 4 * 2.1$
160	550-73TS	Draw arm 拉臂	2	
161	550-74TTS	Bolt 螺栓	2	
031	550-54TS	Ball link 拉杆头	2	
093	550-7-TDT-TS	Socket screw 圆柱头内六角螺丝	1	M4*20
162	550-38-TDT	Main shaft 主轴	1	$\Phi 10 * 170$

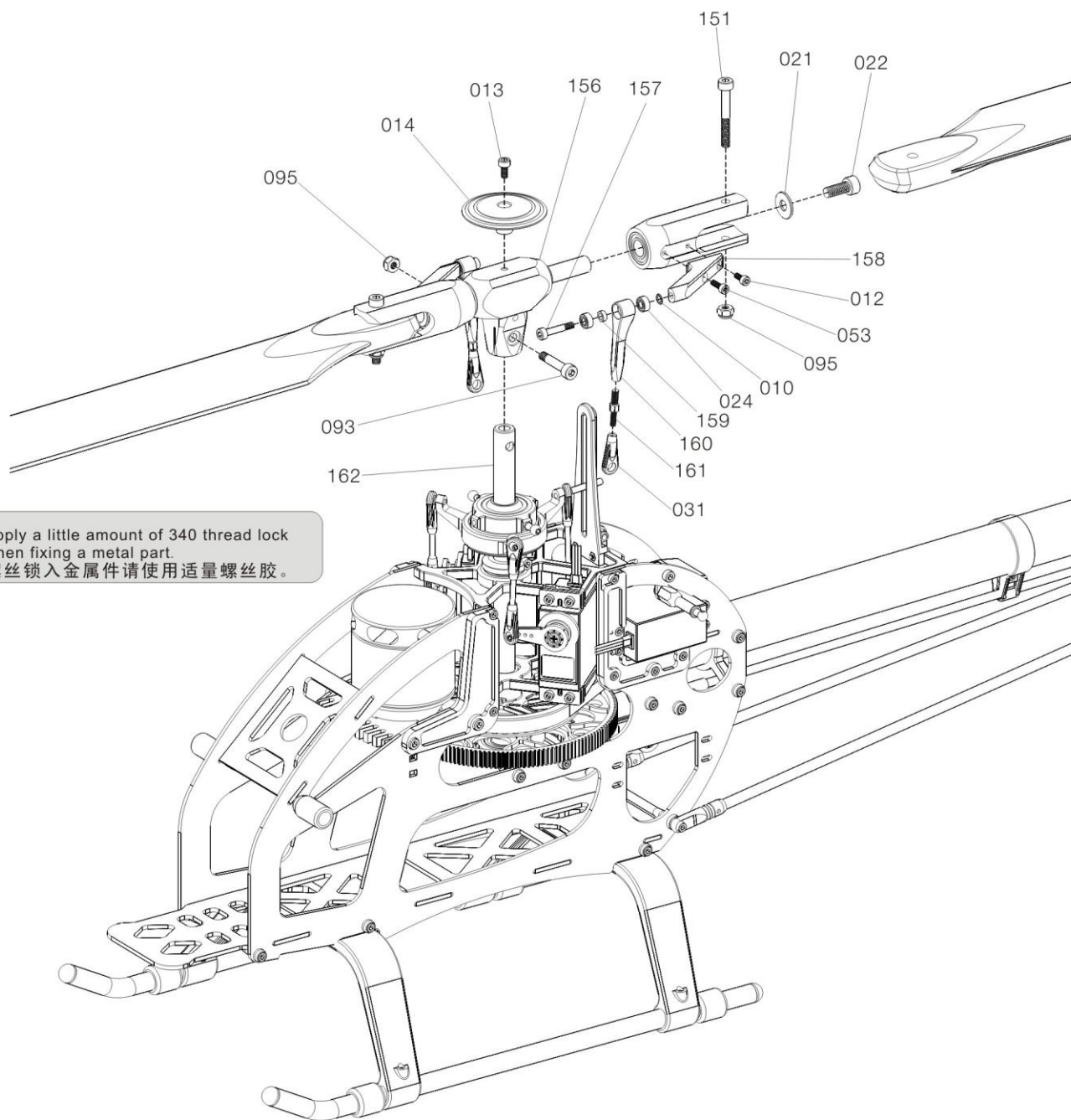

Apply a little amount of 340 thread lock when fixing a metal part.
螺丝锁入金属件请使用适量螺丝胶。

6.ASSEMBLY PROCESS OF FLYBARLESS SYSTEM

无副翼系统组装步骤

Dosage form of spare parts 零件用量表

No.序号	Part No. 配件编号	Description 名称	Quantity 数量	Specification 规格
096	550-56	Socket screw 圆柱头内六角螺丝	2	M3*12
024	550-13TS	Ball-bearing 滚珠轴承	4	$\Phi 3 * \Phi 7 * 3$
102	550-13TS	Alu collar 铝套	2	$\Phi 3 * \Phi 4 * 1.6$
163	550-15TS	Washout control arm 无副翼向位器臂	2	
010	550-15TS	Washer 台阶垫片	2	$\Phi 3 * \Phi 5.5 * 0.5$
101	550-14TS	Socket screw 圆柱头内六角螺丝	4	M2*5
100	550-14TS	Flange bearing 法兰轴承	4	F682ZZ

No.序号	Part No. 配件编号	Description 名称	Quantity 数量	Specification 规格
099	550-14TS	Shear type arm 剪型臂	2	
164	550-4TS	FBL main torot holder arm 无副翼支臂	2	
012	550-4TS	Socket screw 圆柱头内六角螺丝	4	M2.5*6
005	550-58TTS	Linkage ball A 球头A	2	$\Phi 5 * 8.5$
031	550-54TS	Ball link 拉杆头	4	
114	550-53	Linkage rod (A) 连杆A	2	$\Phi 2.2 * 76$

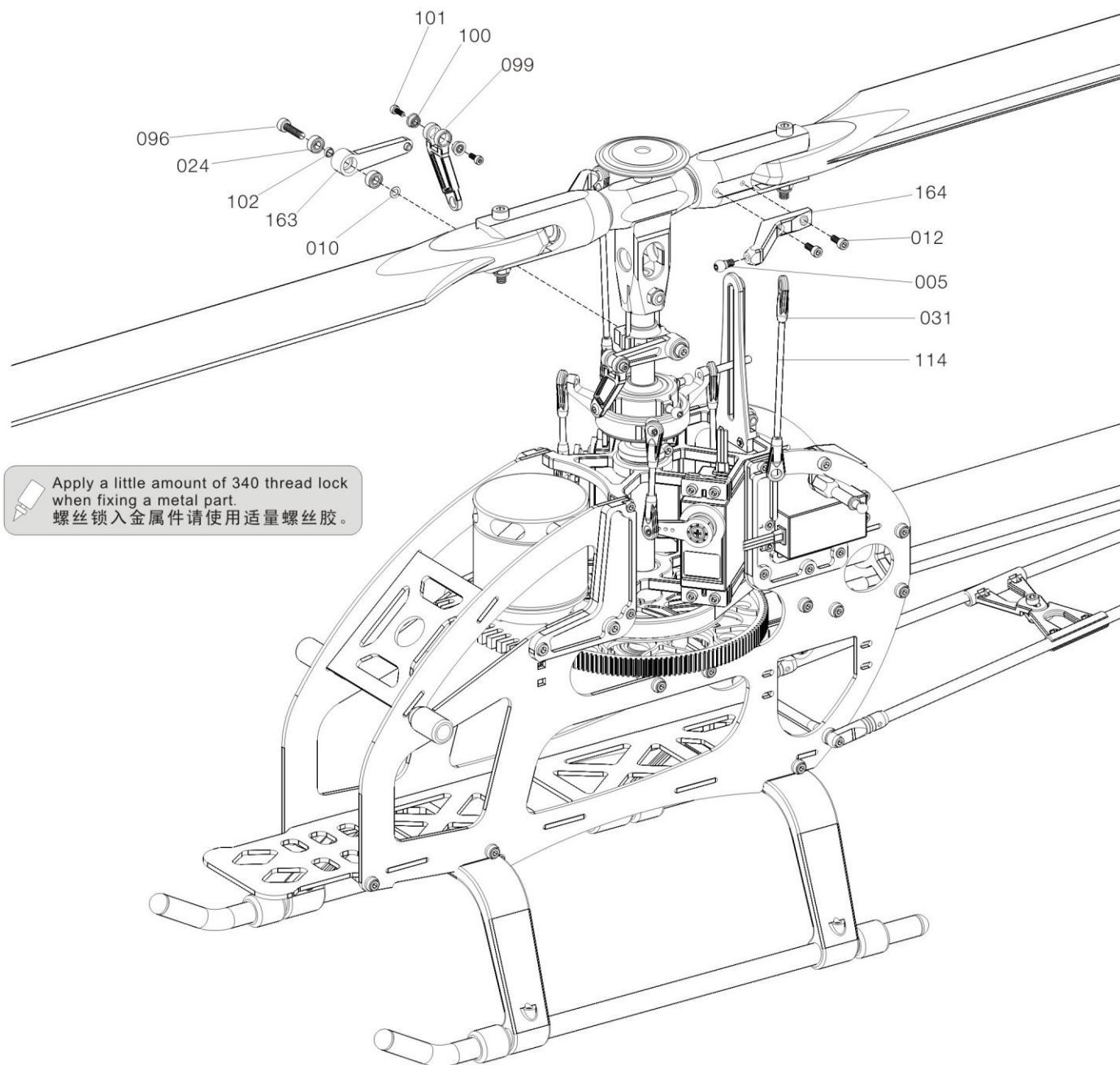

Apply a little amount of 340 thread lock when fixing a metal part.
螺丝锁入金属件请使用适量螺丝胶。

7.EQUIPMENT ILLUSTRATION 设备建议配置图示

PARTS AND EQUIPMENT ASS EMBLY ILLUSTRATION 零件与组件的组装图

Illustration of Main Rotor's Pitch at 0 degree

主旋翼pitch 0度角，各相关结构摆位示意图

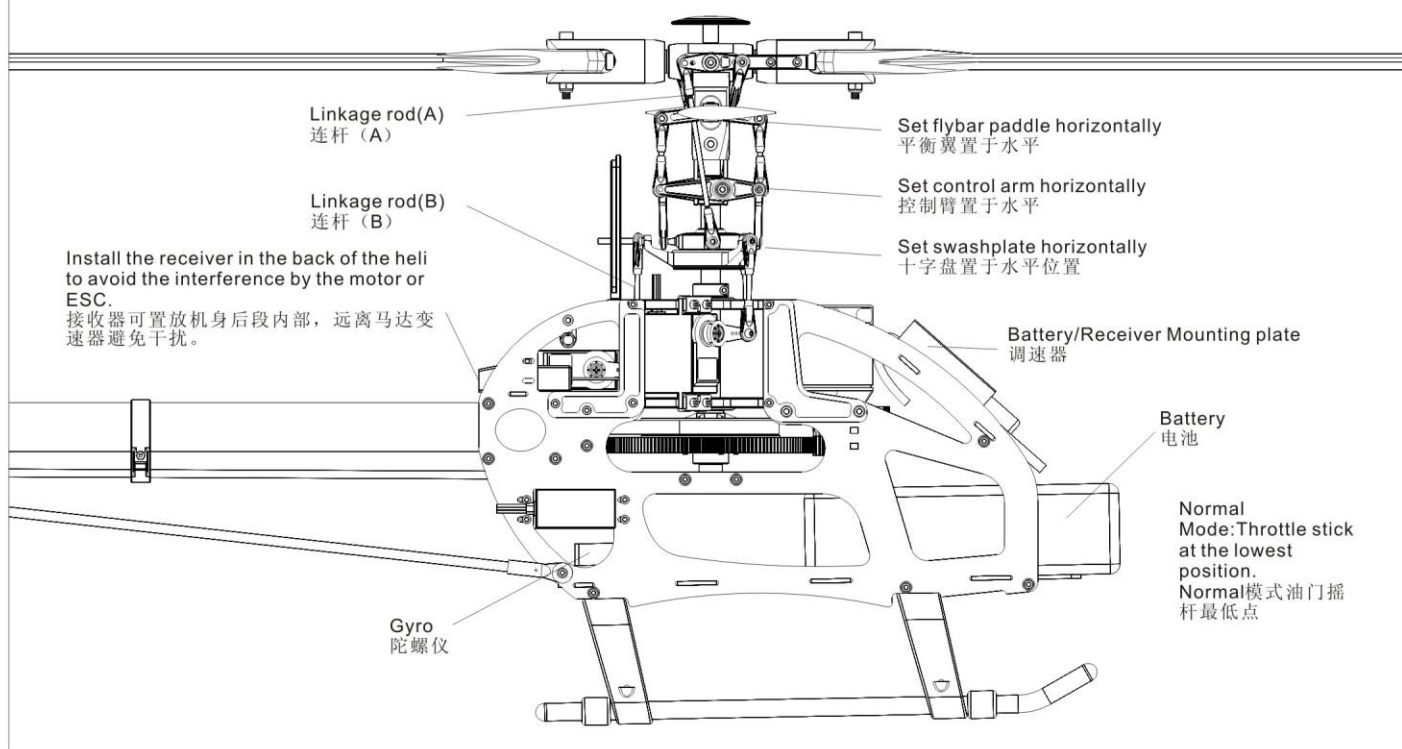

8.MAIN ROTOR BLADE BALANCING AND CORRECTION

设备建议配置图示

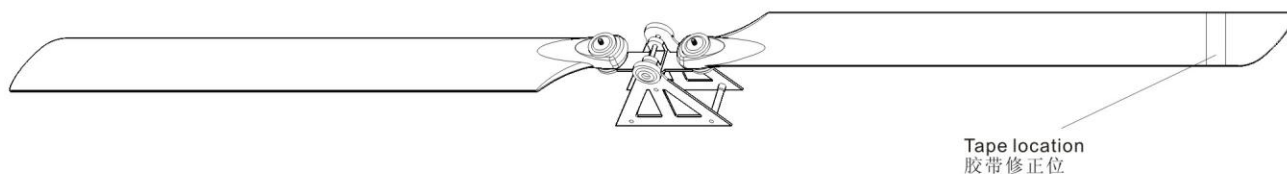

Important-Before flying it is necessary to balance the blades. Screw the rotor blades together as in the illustration. The rotor blades are properly balanced when they are suspended exactly horizontally. If not, the blades are not in equilibrium. This is corrected by applying tape to lighter blade.

当主旋翼转动时，请先执行平衡校正将两支主旋翼使用M3螺丝固定保持两支将成一直线，至于测试跨台后可以用胶带修正达两支主旋翼成水平最佳状态。

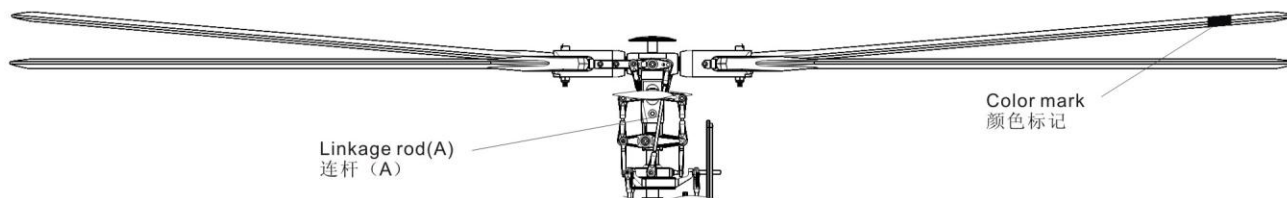

Linkage rod(A): Regular pitch trim (For large variations).
连杆(A)为一般螺距调整(双桨差异大时使用)

Apply a red piece of tape on one blade, or paint a red stripe with a marker or paint to identify one blade. Run the helicopter at a safe distance and have someone look at the spinning blades at the reference angle shown in the photo. If the blade tracking is not set correctly, you will be able to identify the blade with the red identifying mark rotating higher or lower than the other blade.

可使用螺旋桨附赠的红、蓝贴纸分别贴于两桨翼端，或于单桨翼端处画上颜色记号，方便双桨调整辨记。标示颜色桨偏高(螺距过大)请调整连杆(A)修正。

9.PITCH AND THROTTLE SETTING 主旋翼螺距与油门设定

GENERAL FLIGHT 一般飞行模式

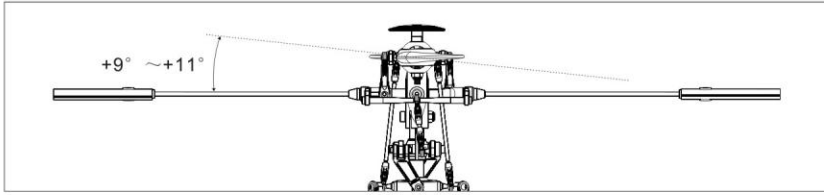

Stick position at high/Throttle 100%/Pitch+9° ~+11°
摇杆高速/油门100%/Pitch+9° ~+11°

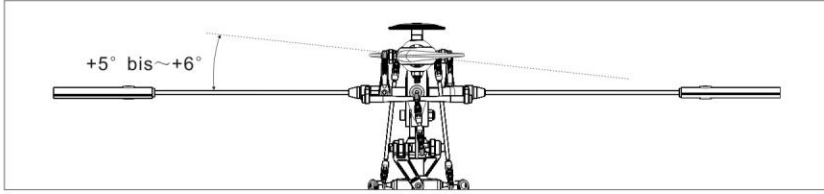

Stick position at high/Throttle 65%~70%/Pitch+5° ~+6°
摇杆停息/油门65%~70%/Pitch+5° ~+6°

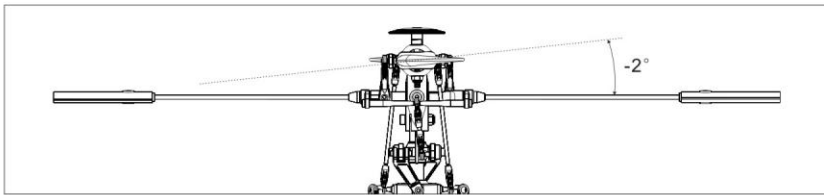

Stick position at low/Throttle 0%/Pitch 0°
摇杆低速/油门0%/Pitch 0°

Standard-Flug		Pitch 螺距
Throttle 油门		
5	100%High speed 100%高速	+9° ~+11°
4	85%	
3	65%Hovering 100%停息	+5° ~+6°
2	40%	
1	0%LOW SPEED 100%低速	-2°

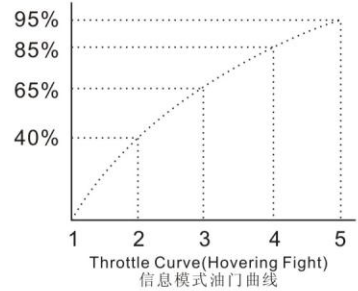

Pitch and Rotation Speed Pitch 与转速关系
TIP:It is recommended to use a lower pitch setting when using higher RPM/Head speed. This will allow for better power.
搭配要领：如果使用较高转速马达动力建议搭配调低Pitch，将获得较佳传动力效能。

3D FLIGHT 3D特技飞行模式

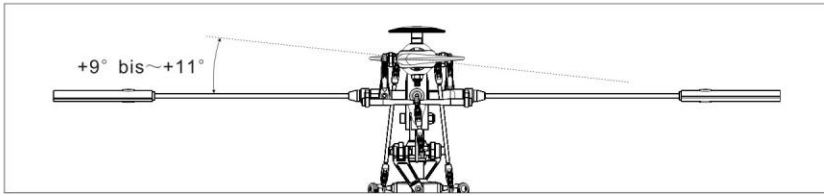

Stick position at high/Throttle 100%/Pitch+9° ~+11°
摇杆高速/油门100%/Pitch+9° ~+11°

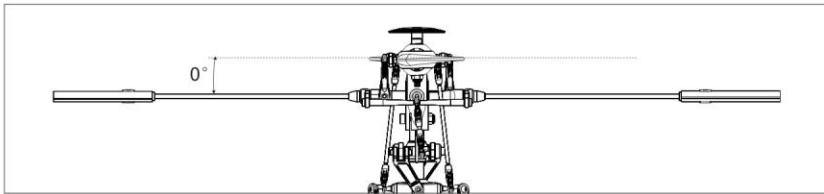

Stick position at high/Throttle 90%/Pitch 0°
摇杆高速/油门90%/Pitch 0°

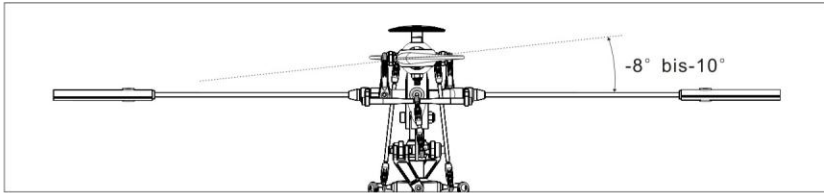

Stick position at low/Throttle 100%/Pitch-8° ~-10°
摇杆低速/油门100%/Pitch-8° ~-10°

IDLE1:SPORT FLIGHT		Pitch 螺距
Throttle 油门		
5	100%	
4	85%	
3	80%	+5° ~+6°
2	85%	
1	90%	-5°

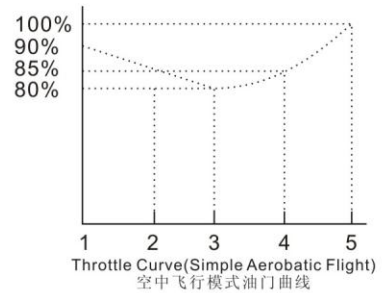

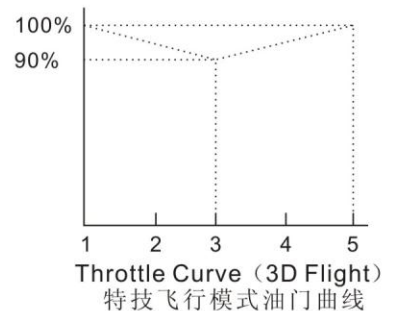

IDLE1:SPORT FLIGHT		Pitch 螺距
Throttle 油门		
5	100%	+9° ~+11°
3	90%	-5°
1	100%	+8° ~+10°

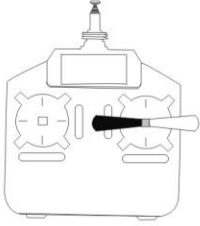
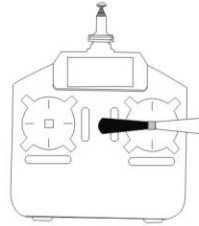
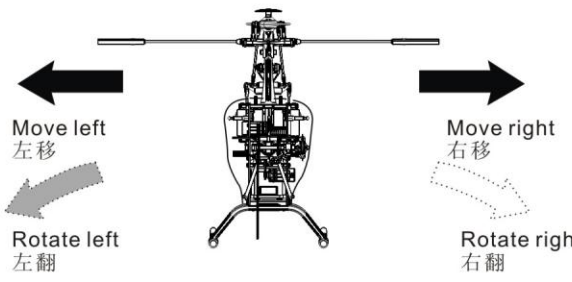
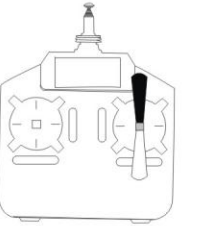
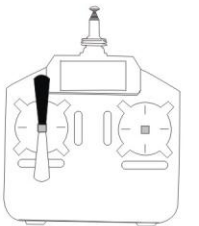
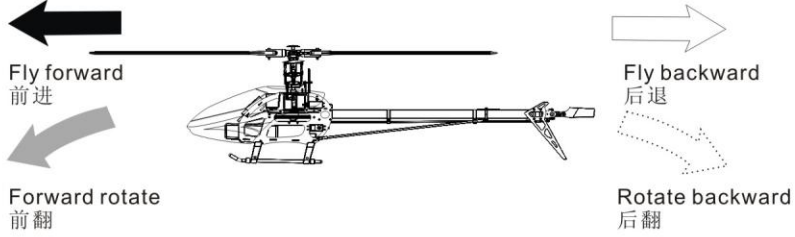
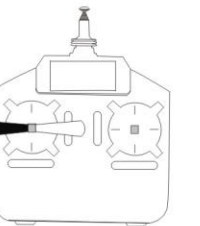
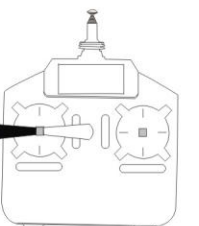
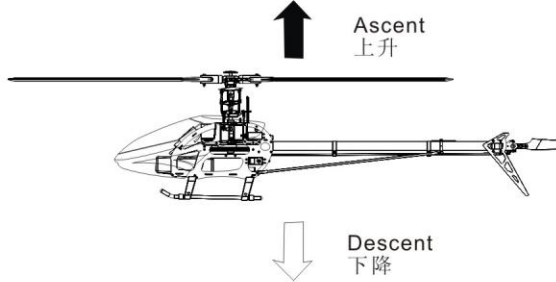

- CAUTION!
注意

- 1.Pitch range:Approx.25 degrees.
 - 2.If the pitch is set too high,it will result in shouter fight duration and poor motor performance.
 - 3.Setting the throttle to provide a higher speed is preferable to increasing the pitch too high.
 - 1.螺距 (Pitch) 总行程约25°
 - 2.过大螺距设定，会导致动力与飞行时间降低。
 - 3.动力提升以较高转速的设定方式，位于螺距调大的设定。

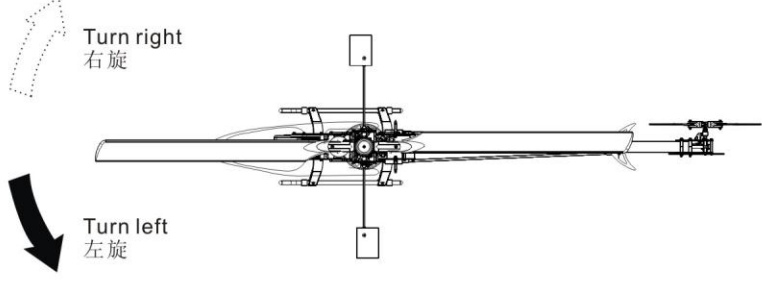
Mode 1	Mode 2		
 <p>Aileron副翼</p>		 <p>Move left 左移</p> <p>Rotate left 左翻</p> <p>Move right 右移</p> <p>Rotate right 右翻</p>	
 <p>Elevator升降/前后</p>		 <p>Fly forward 前进</p> <p>Forward rotate 前翻</p> <p>Fly backward 后退</p> <p>Rotate backward 后翻</p>	
 <p>Throttle油门</p>		 <p>Ascent 上升</p> <p>Descent 下降</p>	
 <p>Rudder方向</p>		 <p>Turn right 右旋</p> <p>Turn left 左旋</p>	

11.PARTS LIST 零件明细(1)



550-3TS
Main rotor holder
大桨夹



550-5TS
Flybar branch
arm of main holder
有副翼桨夹支臂



550-6TS
Control lever arm
支臂摇臂



550-7TS
Main housing
中联



550-36TS
POM Feathering
shaft tube
POM横轴套管



550-37TS
Feathering shaft
横轴



550-35TS
Feathering shaft
rubber ring
横轴减震胶圈



550-8TTS
Brake plate
刹车盘



550-9TS
Flybar control set
日字框



550-10TS
Flybar rod holder
副翼杆固定座



550-11TS
Flybar rod
3.0mm副翼杆



550-12TS
Washout base
向位器



550-13TS
Washout base
control arm
有副翼向位器摇臂



550-14TS
Shear type arm
剪型臂



550-4TS
Flybarless branch
arm of main holder
无副翼桨夹支臂



550-15TS
Washout base
control arm
无副翼向位器摇臂



550-1-TDT
TDT Main rotor
head
TDT旋翼头组



550-7-TDT-TS
TDT Main housing
TDT主中联



550-4-TDT-TS
TDT FBL Main rotor
support ram
TDT无副翼桨夹支臂



550-73TS
TDT FBL Connecting
rod
TDT无副翼转接连杆



550-74TTS
TDT Connecting rod
double ends bolt
TDT转接杆双头螺杆



550-16TS
CCPM swashplate
十字盘



550-17
Main shaft bearing
block
主轴轴承座



550-18
Main shaft bearing
block (down)
主轴轴承下座



550-20
Tail boom
stiffener
尾管固定座



550-21
Motor mount
马达固定座



550-22
Frame strengthening
plate
侧板加强片



550-23TTS
Anti-rotation
bracket
十字盘导轨



550-50
Main gear mount
大齿盘固定座



550-51
Main drive gear
大齿盘



550-52
Tail drive gear
小齿轮



550-40TS
Main shaft lock
ring
主轴限位环



550-38
Main shaft
主轴



550-41
CF Frame set
碳纤维侧板



550-42
CF bottom plate
碳纤维底板



550-43
CF battery plate
碳纤维电调板



550-44
CF plate of
receiver
碳纤维接收机板



550-45
Canopy mounting
bolt
机架连接柱



550-63
Canopy mounting
bolt
头罩支柱



550-83TTS
Canopy brace
rubber gasket
头罩支柱胶圈



550-38-TDT
TDT Main rotor
housing
TDT主轴FBL



550-71
Motor pinion 14T
马达齿14T



550-72
Motor pinion 15T
马达齿15T



550-75TTS
Canopy rubber
ring
头罩胶圈



550-79TTS
Mounting bolt
holder
机壳铝柱固定板



550-64TTS
Servo mounting
plate
舵机压片



550-65
Servo mount
舵机安装座



550-34
belt wheel
压带轮



550-67
Skid pipe
脚架铝管

11.PARTS LIST 零件明细(2)



550-68
Landing skid
脚架



550-69TTS
Landing skid
rubber ring
脚架管减震圈



550-48
Tail boom
尾管



550-60
Tail boom brace
尾撑杆



550-66
Drive belt
皮带



550-61TTS
Tail boom brace
damping plate
尾撑杆减震片



550-46TTS
Stabilizer mount
水平翼固定座



550-49TTS
Tail boom brace
mounting ring
尾推杆固定环



550-47TTS
Carbon horizontal
stabilizer
碳纤维水平翼



550-32
Vertical fin
垂直翼



550-24TTS
CF tail unit plate
碳纤维尾波箱侧板



550-33TTS
Tail unit
connecting bolt
尾波箱连接柱



550-27TTS
Tail rotor shaft
assembly
尾轴



550-28TTS
Tail pitch
assembly
尾推滑块



550-29TTS
Tail arm
尾摇臂



550-30TTS
Tail arm holder
尾摇臂固定座



550-31TTS
Tail unit holder
尾波箱座



550-82TTS
Tail rotor
holder
尾桨夹总成



550-80TTS
TDT Tail rotor
holder
TDT尾桨夹



550-81TTS
550 External
thread tail hub
外螺纹尾中联



550-53
Linkage rod
拉杆包



550-54TS
Linkage ball
球头扣包



550-55
Screw washer
螺丝固定垫片



550-56
Screw set
整机螺丝包



550-57
Washers
整机垫片包



550-58TTS
Stainless ball
part
不锈钢球头包



550-62
Tail linkage rod
尾推杆



550-70TTS
Main blade
holder
浆托



550-76TTS
battery tape
电池绑带



550-77TTS
Magic tape
魔术贴



550-78
FG Canopy
机头罩



1193-6
CF Tail blade
碳纤维旋翼



1193-9
CF Main blade
碳纤维主桨



1191-550
CF Flybar paddle
碳纤维副翼

12.REGULAR MAINTENANCE 常规维修

Regular maintenance is required to keep the KDS 550 helicopter in optimal and safe flying condition. The model requires precise configuration of the components and settings to be kept by the owner. Maintain regular maintenance on the model to avoid accidents or loss, and optimum performance.

请定期检查：KDS 550 电动摇控直升机为精密零组件构成之精细模型商品。所以飞行者须注意确保各控制组件及结构之性能良好，使能发挥优异稳定飞行特性。如果您的维护不当，飞行时将可以导致意外或任何损失，建议您注意养成直升机定期检查的习惯，以确保让您的爱机随时保持最佳性能。

MAIN ROTOR CHECKLIST 主旋翼机构检查重点

1. Main Rotor Housing: when the main rotor housing is worn or faulty, there will be obvious vibration and poor flight control. Check the main rotor, main shaft, and feathering shaft for wear or deformity. Replace parts as necessary to eliminate imbalance.
 2. O-Rings: The O-Rings will lose their elasticity over time. This will cause excess play on rotor and cause instability. Replace them as needed.
 3. Main Rotor Holder: When the helicopter does not fly or reacts sluggishly, even after checking for proper setting of pitch and throttle, check the following items: Plastic parts, Bearings, Ball bearings, Rotor Blades. Check for excess play or broken parts, or binding or restricted movement. It is important to check for main rotor balance before each flight. Operating the model when out of balance will cause excessive wear and premature failure of parts, possibly resulting in a dangerous situation.
 4. Control Arm Assembly: Check regularly for cracked, worn, bent or binding control arms and pushrods. Smooth movement of control arms and linkages is required for stable, vibration free flight.
 5. Swashplate: Check for excess slop in the main ball where the main shaft rides on, and slop or looseness between the plastic and metal surfaces. Swashplate wear will result in poor stability and lack of control during flight. Replace them as necessary.
1. 主旋翼固定座：当主旋翼运转发生异常时，飞行当中发生的震动情形，请检查主旋翼、横轴、主轴是否有变形或平衡不良，必要时请将主旋翼头固定座更新。
2. 主旋翼缓动油封：缓动油封长期使用会发生弹性疲乏，会影响飞行稳定性，此时建议更新。
3. 主旋翼夹座：主旋翼夹座一般飞行前虽然确认过螺距，但实际飞行时仍需增加螺距行程才足够使用，如果飞行时升降动作迟缓情形：检查重点包含了塑胶件以及轴承、球轴承等，塑胶件及球轴承若发现明显间隙，轴承钢轴脱落均需要更换新品。注意：飞行前主旋翼必须详细的做好动平衡的动作，并请修正双桨不良的状况，以提升升力效能，注意因平衡不佳将各导致零件损坏与松脱。
4. 控制臂组：定期检查各控制臂控制滑顺，减少左右摇晃虚位可确保停态稳定性能。
5. 十字盘组：当十字盘组发生严重虚位时，会导致停态时稳定性能不稳定，操控性能也会劣化，并可能发生不明原因的双桨现象，严重时则必须更新。

FUSELAGE/CHASSIS 机身组检查重点

1. Main Shaft Bearing: Normal replacement interval for proper operation is between 60-100 flights. If flying 3D or extreme aerobatics often, inspect the bearing more frequently and shorten the interval as necessary.
 2. One-way Bearing: One-way bearings have longer lifetimes. Failure is not common. To keep the one-way bearing in good operation, remove it to clean and lubricate after every 50 flights. If the main drive gear is loose, you should replace the one-way bearing.
 3. Drive Belt: KDS uses only top quality, stretch-proof belts. It is however, impossible to prevent the belt from stretching or wearing out. Check belt tension regularly, and check for the wear on the teeth. Replace it as necessary.
1. 主轴轴承：主轴轴承经长期重负载运作，正常飞行约60-100趟必须更换新品以维持动作顺畅度。但是若经常进行激烈的3D飞行，建议您必须时常检查主轴轴承，当发现主轴轴承有明显的间隙或是转动有明显的阻碍都必须更换新品。
2. 单向轴承组：单向轴承级并不常发生损坏的情形。但是为了保持良好的顺畅的运作，建议您约50趟的周期当中请拆卸下来上油。如果发生主齿轮明显异动，请立即更换单向轴承盘。
3. 尾转动皮带：尾转动皮带虽然采用日制原装纤维耐变形皮带，长时间使用时仍然会产生延展的现象。请随时检查施以心向尾管重新拉伸修正调整，以维持良好的尾舵控制机能。如果当您发现皮带的边缘磨损严重现象或是断齿的状况，为了维护飞行的安全建议您将它更新。

LINKAGE RODS & CONNECTING PARTS 控制杆组头检查重点

During assembly, take special care to keep the connecting parts in smooth operation, and avoid excess play or binding. Failure to do so will result in poor flight stability. The linkage rods and ends will break and wear due to normal usage, crashing, and poor maintenance and environment. Check for wear and proper operation regularly, replace them as needed.

控制连杆、控制臂连接座、升降舵连接座组装时请特别注意各连接部位需保持滑顺且尽量减少轴向左右摇晃间隙，此要点将严重影响飞行稳定性各连接杆如因跌机损坏之外。因自然磨损或是因飞行场地恶劣因素也会发生磨损或松脱的情形。当您发现任何连接杆发生间隙或是轻推即可脱出，建议您立即更新，确保飞行性能与安全。

TAIL ROTOR SYSTEM 尾旋翼系统检查重点

1. Tail Rotor Control Set: Check the tail rotor bearing regularly. If there is excess play or gaps, replace it immediately. Avoid any binding or improper contact on the tail components and bearings as this will cause excess wear and heat, potentially melting or deforming the tail system.
 2. Tail Unit Assembly: Avoid flying in tall grass or weeds. If grass or weed becomes lodged in the tail rotor unit, it will interfere with the operation, and cause the helicopter to lose control. Always check for foreign objects in the tail and clean them off immediately. Avoid using lubricants on the exposed surfaces of the model as it will attract and collect dirt and debris, and cause failure.
 3. Tail Rotor Housing: Disassemble tail rotor housing for cleaning and maintenance after every 50 flights. If the tail does not operate smoothly or shows any signs of stress or wear, please replace immediately.
 4. Tail Rotor: Check the tail rotor blades regularly for damage, especially if the helicopter ever strikes the ground while flying, or after hard landings. Damaged tail rotor blades can induce vibration.
1. 尾齿轮组：尾齿轮组请注意尾旋翼轴承的检查，当您发现轴承有明显的间隙时请更新，避免轴承咬死，并注意尾舵轮不可将它锁死。必须能保持顺畅运动以免发生塑胶件熔毁的情形。
2. 尾旋翼控制滑座：当您于草地飞行时，请注意避免尾旋翼滑座是否有发生落地时卷入杂草的状况，若有必须立即将它清除再进行下一次飞行，否则可能会因为杂草纤维阻碍动作。造成尾旋翼控制失常的情形，平常保养尽量避免使用润滑油于外部结构，避免沾染灰尘等杂物，严重时甚至会发生其它部位轴承磨损及尾旋翼滑座无法运作的情形。
3. 尾旋翼固定座：尾旋翼固定座飞行约50趟左右请拆卸进行清洁保养，确认轴承间隙是否正常。如转动不顺或间隙过大请更换轴承，确保控制系统完善。
4. 尾旋翼：飞行时发生触地的情形请立即检修。若发现尾旋翼有明显的外观损坏时请立即更换。以避免发生尾部震动并因此损坏其它零件，确保飞行品质。



SPECIFICATION (规格)	INNOVA 550
Length (长度)	1120mm
Width (宽度)	180mm
Height (高度)	366mm
Main Rotor Diameter (主旋翼直径)	Φ 1250mm
Main Blade Length (主旋翼长度)	550mm
Motor Pinion (马达齿)	14T
Brushless Motor (无刷马达)	1200KV
Main Drive Gear (主传动齿轮)	150T
Autoration Tail Drive Gear (尾驱动主齿)	42T
Drive Gear Ratio (齿轮传动比)	10.7:1:4.6
Weight(w/o power) (空机重量, 不含马达)	1650g

KDS MODEL

SHENZHEN KDS MODEL TECHNOLOGIES CO.,LTD

Block4, Fengmen Industrial Park, Egongling Village, Pinghu Town, Longgang District, Shenzhen 518111, China
www.kdsmodel.com