

Important Information about GloBee Glow Plugs

To start your Cox .049/.051 engine, the coil in your GloBee glow plug must glow bright orange. To test your glow plug battery with your glow plug clip, and cup your hands around the plug to keep it out of direct sunlight. BE CAREFUL, THE PLUG WILL GET HOT QUICKLY. The entire coil should glow bright orange.

If no part of the coil glows bright orange then disconnect the glow plug clip and check your battery and wire connections. Remember, GloBee plugs require 2 VOLTS, and may not operate on 1.5 volts (as from a dry cell battery) or 1.2 volts (as from a NiCad battery).

If only a portion of the coil glows orange, then the coil is either touching itself and creating an electrical short circuit, or it is touching the glass insulation sealing the top of the plug and losing heat. In either case, disconnect the glow plug clip and CAREFULLY separate the loops of the coil from each other, and lift the coil slightly away from the glass insulation with the tip of a hobby knife. Test the glow plug again before installing it in your LMH-100.

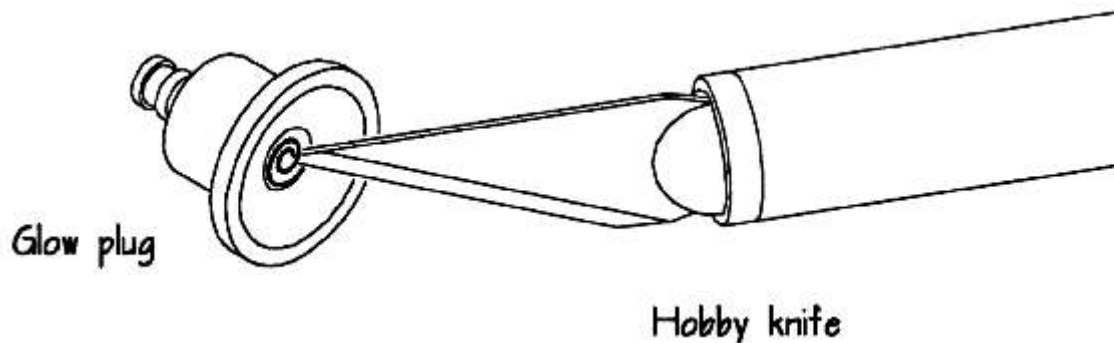

Alternate Fuels

Many LMH-100 fliers have reported good results with fuels containing less than 35% nitromethane such as Byron's 25% nitro. When selecting a fuel, make sure that the lubricant is at least 50% castor oil. Synthetic oils break down at high temperatures, so running fuels with 100% synthetic lubricant can ruin your Cox .049/.051 engine.

Electric Starter Effect on Glow Plug Operation and Engine Starting

Cox TD .051/H engines usually start easily, but some LMH-100 fliers have reported difficulties starting their engine even after reviewing the Engine Trouble Shooting section in the LMH-100 Operator's Guide. Some mention that their engine starts easily by hand when run on a bench with a propeller, but will not start in their LMH-100 helicopter.

On-going difficulty with engine starting is often a sign of a field-equipment problem. Many R/C fliers have a field box with a small 5 Ah Motorcycle battery that is used to light the glow plug and turn the electric starter motor when starting the engines in their models. Common electric starters are designed to start .40 and .60 sized engines, and therefore draw high current from the field box battery.

Even though a glow plug may appear to glow orange (hot) when connected to the field box battery by itself, it may cool substantially when the electric starter is operated. This means that the glow plug will stop working just as the starter motor begins to spin the engine, so the engine may not start. The plug will heat up again when the starter motor is turned off, making it appear as though the plug is working properly.

To see this effect, plug a glow plug clip and a standard electric starter into a power panel. Connect the glow plug clip to a glow plug, and cup your hands around the plug to keep it out of direct sunlight. The coil should glow bright orange. **BE CAREFUL, THE PLUG WILL GET HOT QUICKLY.**

Turn on the electric starter. If the field box battery is small, old, or low on charge, the plug coil will cool and stop glowing. Turn off the starter and the plug will again glow orange. Also try operating the starter in one second pulses. Notice that the glow plug remains hot longer if the starter is pulsed.

The following are suggested to detect/correct equipment-related engine starting problems:

1. Test glow plug with electric starter running
2. Recharge field box battery before every flying session
3. Replace old (worn-out) field box battery with new battery
4. Run large starters in short (one second) pulses.
5. Connect field box battery to a car battery for higher electrical current.
6. Use a smaller starter made for starting small engines
7. Power glow plug and starter with separate batteries.
8. Shorten leads on glow plug clip to reduce the electrical resistance caused by long wires.

Stability, Control Power and Climb Performance

The flight stability and control power of the LMH-100 are affected by the rotational speed of the main rotor. At high rotor speeds, the main rotor blades generate high gyroscopic forces that stabilize the main rotor, and minimize the effects of disturbance such as wind gusts. At high speeds, the rotor blades can also generate the high aerodynamic (air) forces needed to forcefully push the LMH-100 around when the pilot moves the controls. On fixed-pitch helicopters such as the LMH-100, the pitch of the main rotor blades determines the operating speed of the main rotor, and so directly affects stability, control power, and climb performance.

Generally, high blade pitch improves climb performance, but reduces stability and control power in hover. This is because rotor blades operating at a high pitch angle produce high lift at a relative low rotor speed. At the low speeds needed to hover, the rotor blades do not generate the gyroscopic forces needed for solid stability, or the aerodynamic forces needed for snappy control. Low blade pitch, on the other hand, increases rotor speed and stability, but hurts climb performance.

The LMH-100 climbs best with plus-six blade grips. Plus-six blade grips increase natural blade pitch by six degrees, and are identified by six raised dots on the top of the grips. The LMH-100 is generally more stable with the blades pitched to five degrees. To pitch the blades to five degrees, replace ONE plus-six grip with a plus-four grip, and re-track the rotor blades (as described in the LMH-100 Operator's Guide) so that both blades are pitched to five degrees.

When flying at low elevations (especially near sea level) with plus six grips, the LMH-100 may leave the ground with out adequate rotor speed for acceptable stability and control power. The common solution to this problem involves reducing blade pitch to increase rotor speed. To avoid over-speeding the engine, the nitromethane content of the fuel is normally reduced along with the blade pitch. Alternately, weight may be added to keep the LMH-100 on the ground at low rotor speeds (although it seems odd to purposefully add weight to a flying machine).

If, after adjusting the blade pitch, you would like even more control power, try moving the Z-links in the rotor head to the alternate (inner-most) holes on the pitch plate and mixing arms. This will reduce the stabilizing input of the Arlton Subrotor and increase the control input of the swashplate to the main rotors (thereby decreasing stability and increasing control power). By adjusting the blade pitch and Z-link position, you should be able to tune the flying qualities of your LMH-100 to some satisfactory point.

WARNING!

BE CAREFUL NOT TO REDUCE BLADE PITCH SO MUCH THAT THE MAIN ROTOR EXCEEDS ITS MAXIMUM RATED SPEED SINCE EXCESSIVE SPEED COULD DAMAGE THE ENGINE. WHEN FLYING AT LOW ELEVATIONS (NEAR SEA LEVEL), OR WHEN USING LOW BLADE PITCH (SUCH AS TWO PLUS-FOUR GRIPS), USE A FUEL CONTAINING LESS (20%-25%)NITROMETHANE TO REDUCE THE LOAD ON THE ENGINE.

Effect of CA Accelerator and Thread-Lock on Plastic

CA accelerator is a liquid commonly brushed or sprayed onto cyanoacrylate (CA) glue to make the glue harden more quickly. Thread-lock, such as *Loctite* brand thread-lock, is a liquid commonly applied to screw threads to keep screws from loosening and falling out.

Some brands of CA accelerator and thread-lock contain chemicals, such as acetone and other solvents that can damage parts from certain types of plastic. Most plastic parts of the LMH-100 helicopter are not particularly sensitive to these chemicals. The tail rotor gearbox, canopy mounting brackets and fuselage canopy, however, can be affected.

When applied to the surface of a part made of sensitive plastic, the chemicals in CA accelerator and thread-lock can soak into plastic and cause the plastic to become brittle. These chemicals can also cause the surface of the plastic to craze (form small cracks) that allow solvents to penetrate deeper into the plastic and weaken the part. Some gearbox cracks on the LMH-100 helicopter have been attributed to the use of accelerator when gluing the vertical fin to the gearbox, or the use of thread-lock on the tail rotor bellcrank bolt.

In general, do not apply CA accelerator to the tail rotor gearbox, canopy mounting brackets or fuselage canopy of the LMH-100 helicopter. If using thread-lock with plastic parts, make sure that the thread-lock is labeled "plastic compatible" by the manufacturer.

Engine Problems Due to Fuel Contamination

Ninety percent (90%) of the technical questions received by Lite Machines on the Norvel Vmax-6 helicopter engine involve a fuel-related problem. The proper choice of fuel and field equipment is important to achieve the best performance from your Norvel engine.

Effect of Fuel Contamination

Certain brands of model engine fuel contain chemical additives that can foul the glow plug on the Norvel Vmax-6 helicopter engine. Sometimes engines operated on these fuels will run well for a flight or two, but then lose power. Sometimes engines will not start at all. These problems are commonly caused by contaminants that coat the glow plug coil and preventing the glow plug from operating properly.

All model glow-engines use a glow plug with a platinum metal glow plug coil. The platinum metal in the coil acts as a catalyst to maintain properly combustion of the air/fuel mixture in the engine. In order for glow engines to operate properly, the air/fuel mixture must actually touch the platinum wire for the catalytic reaction to occur. If the wire is coated with anything, even if only a few atoms thick, the catalytic reaction cannot occur and the engine stops running.

Rubber Contaminates Fuel

Many varieties of rubber will dissolve in glow fuel and quickly foul the glow plug. Avoid rubber fuel bulbs, syringes with rubber inserts, and neoprene fuel line when transferring fuel to your Lite Machines helicopter. Use only silicone fuel line and plastic (polyethylene) containers to store or transfer fuel.

Contaminated Glow Plugs Must be Discarded

After a glow plug coil has been contaminated, there is no practical way of cleaning it. Make sure to discard the contaminated glow plug when changing to a new fuel or after using rubber in the fuel system.

Needle Valve Damage

It is possible to damage the needle valve on the Norvel Vmax-6 engine by overtightening the needle valve in the spraybar assembly. Overtightening the needle valve can result in a notch or groove around the tapered end of the needle valve. This notch or groove prevents the needle valve from finely metering the fuel into the carburetor, and makes engine starting almost impossible. Even a small groove will make needle valve adjustments difficult, and engine operation erratic.

To determine if a needle valve is damaged, compare it to the drawings below. If the needle valve is notched or grooved, replace both the needle valve and spraybar assembly, since the interior of the spraybar will likely be damaged also.

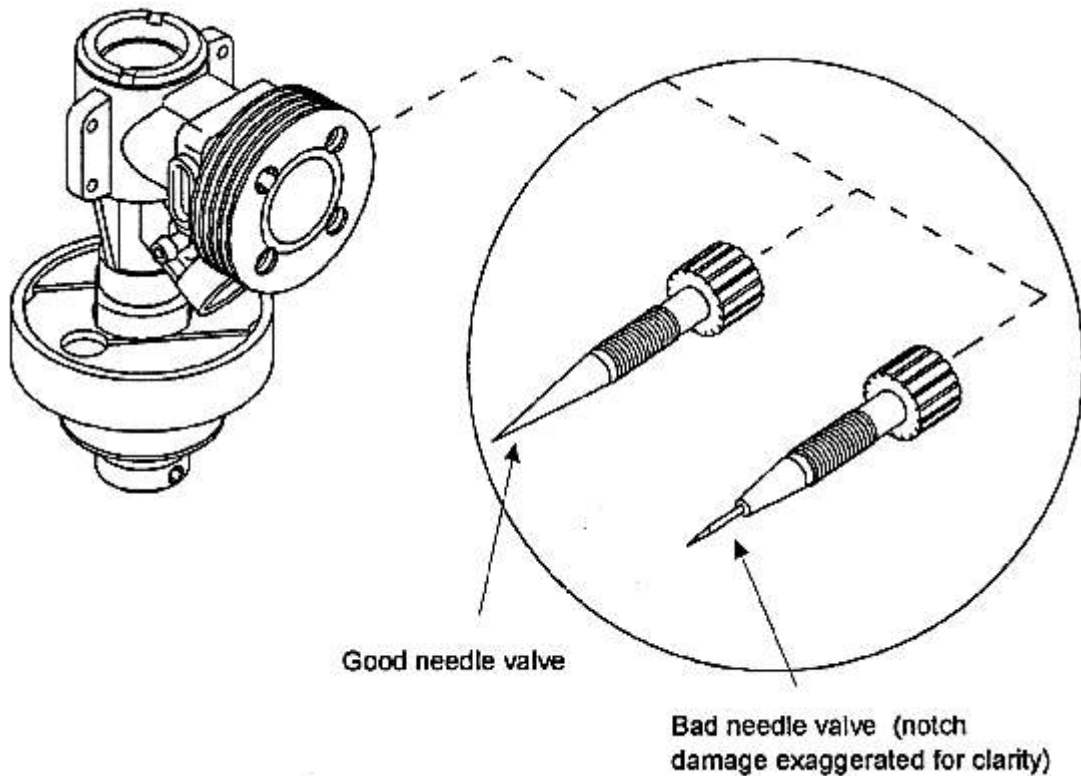

Recommended Fuels for Norvel Vmax-6 Helicopter Engines

Certain brands of model engine fuel contain chemical additives that can foul the glow plug on the Norvel Vmax-6 engine. Sometimes engines operated on these fuels will run well for a flight or two, but then lose power. Sometimes engines will not start at all. These problems are commonly caused by contaminants that coat the glow plug coil and prevent the glow plug from operating properly. Common fuel contaminants include fuel additives that are meant to keep large engines from rusting.

The following brands of fuel are known to foul glow plugs on Norvel Vmax-6 engines (do **not** use these fuels):

- 1) **Byron's standard fuels**
- 2) **Powermaster fuel**

The following fuels are recommended (many other fuels will work as well):

- 1) **Norvel NVX 15% to 25% nitro**
- 2) **Morgan's Omega 15% nitro**
- 3) **Sig Champion Racing Fuels, 15% to 25% nitro**
- 4) **Byron's 25% nitro 1/2A Blend**

Do Not Use Fuels Containing Only Synthetic Oils

Some brands of fuel contain only synthetic oils that break down at relatively low temperatures. During a lean run, synthetic oils may provide insufficient lubrication. In the extreme, the lack of proper lubrication can strip the plating from the piston cylinder walls or even lead to piston seizure and connecting rod breakage.

Do not use model engine fuels containing only synthetic oil with your Norvel Vmax-6 helicopter engine. Use only fuels containing castor oil or castor/synthetic oil blends. For instance, do not use **Morgan's Cool Power** fuel with synthetic oil, instead use **Morgan's Omega** fuel with castor/synthetic oil blend.

Effect of Fuel Line Vibration on Engine Performance

In normal operation of a model piston engine (such as in a model boat, airplane or helicopter) fuel from the fuel tank is transferred to the engine through a flexible fuel line (usually made of silicone tubing). The fuel tank itself is normally located inside a body or framework of the model, so the fuel line generally must pass through a bulkhead or wall in order to reach the engine. Modelers typically seal the hole in the bulkhead or frame to prevent fuel from entering the body of the model, and often support the fuel line in some fashion to prevent the fuel tubing from chaffing against the framework.

If the fuel line is securely attached to the model body or framework, engine vibration transmitted to the fuel tubing can reduce the fuel flow through the tubing. This means that the engine may idle well (when the vibration level is low), but may not run at top speed (when the vibration level is high). The engine may also overheat at high throttle settings (at high vibration levels) because fuel flow is reduced and the fuel/air mixture set by the needle valve on the carburetor goes "lean".

To reduce the possibility of fuel line vibration, do not attach the fuel line securely to the model body or framework. Instead, use oversize holes in bulkheads to allow the fuel line to slide easily relative to the body or framework. In addition, avoid securing the fuel tubing in an orientation parallel to the engine piston cylinder. Because piston engines produce a small explosion and shock on every piston stroke, vibration is highest in the direction of piston travel (parallel to the piston cylinder).

If you own a Lite Machines Model 110 helicopter, make sure the fuel line slides easily through the fuel line hole in the keel. If you are at all unsure of your fuel line installation, remove (and discard) the rubber grommet to allow the fuel line to slide more easily. After about every thirty flights inspect the fuel line for chaffing against the keel.

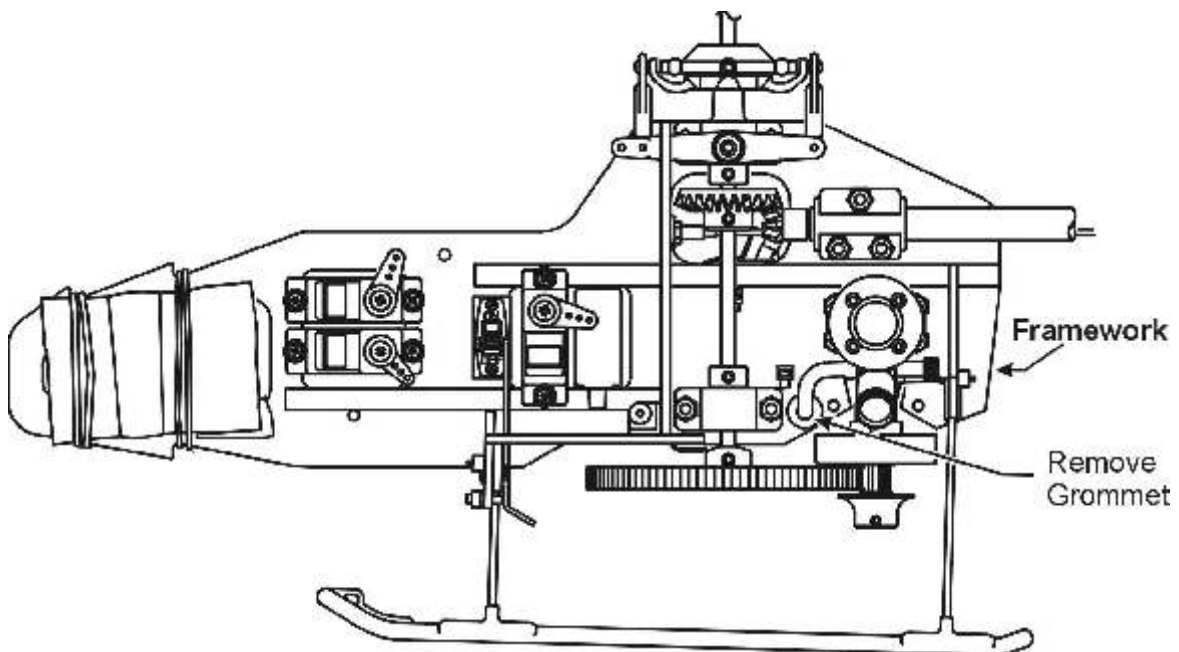

This Technical Bulletin supplements the information already found in the *Corona* Construction Manual and Operator's Guide regarding installation and operation of the *Fusion 35* speed controller in the Lite Machines *Corona* electric helicopter.

Incorrect assembly, reverse voltage, crashes, high currents and natural variation among electrical components (which include integrated circuit (IC) chips, electrical connections, motors and wiring), can all contribute to stress and failure of electrical components. Weak components can fail soon after they are placed in service. This is called "infant-mortality syndrome."

Unlike mechanical components, which typically show signs of wear or damage before failure, electrical components can fail suddenly without warning. Failures are more likely to occur during or after periods of heavy use, or after a change has been made to the electrical system (such as after the replacement of a worn or damaged component). When flying any radio controlled model keep in mind that component failure in the radio system, servos, motor, motor speed controller or gyro stabilizer can cause the model to operate erratically and/or uncontrollably. **NEVER FLY ABOVE OR AROUND PEOPLE OR PROPERTY IN CASE YOU LOSE CONTROL OF YOUR MODEL THROUGH SOME UNEXPECTED CONDITION SUCH AS COMPONENT FAILURE.**

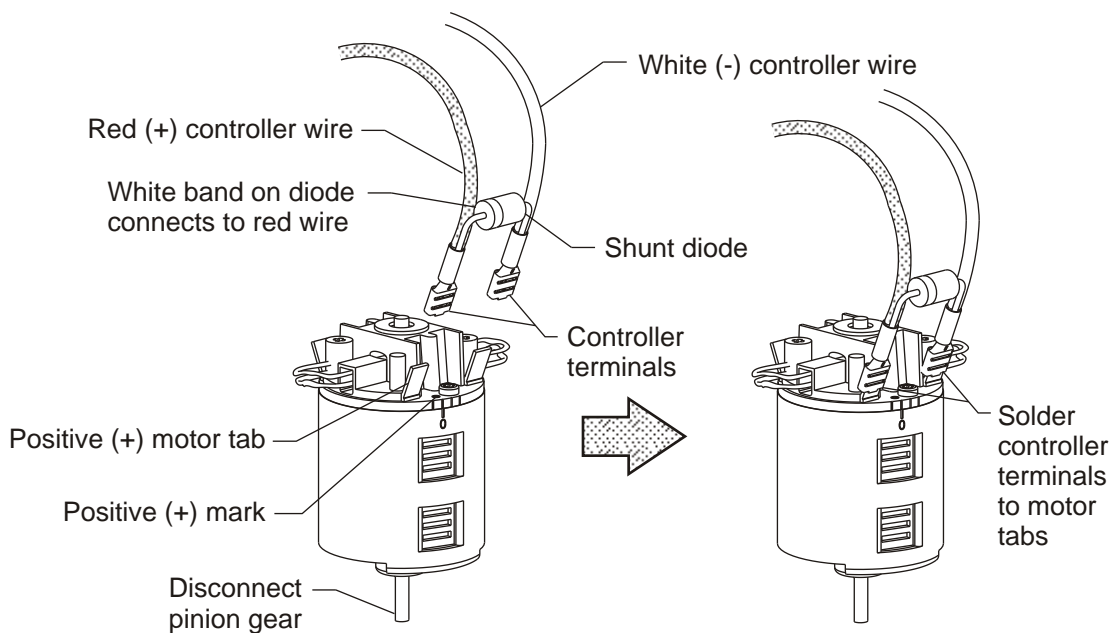

Motor installation.

1. Disconnect the motor pinion gear on your *Corona* helicopter so that the rotor blades cannot start turning unexpectedly and strike you or someone else.
2. Follow the instructions contained in the *Corona* Construction Manual, and the figure shown above, to connect the *Fusion 35* controller to the motor in your *Corona* helicopter. Attach the red controller wire to the positive (+) motor terminal, and the white wire to the unmarked negative terminal.
3. Check that the controller wires are connected properly, and solder the terminals to the motor tabs.

WARNING: The *Fusion 35* controller is equipped with a shunt diode across the motor power leads for additional protection against component damage. **DO NOT REMOVE THE SHUNT DIODE. IF THE DIODE IS DAMAGED OR REMOVED, RETURN YOUR CONTROLLER TO CASTLE CREATIONS FOR SERVICE.**

Spherical Cylinder Seals and *Vmax* Engines

Norvel *Vmax-6B* and *Vmax-7* engines now include a spherical seal washer which can improve the seal between the piston cylinder and glow plug. The spherical seal fits into the base of the special heat sink and uniformly distributes sealing pressure along the outer edge of the glow plug. For best operation, always use the spherical seal and spherical seal heat sink together. The effect of the spherical seal can be increased in some cases by lightly greasing the spherical seal washer with high temperature grease before assembly.

Note that the piston cylinder on the *Vmax-6B* engine is slightly taller than the cylinder on the standard *Vmax-6* to allow for the added height of the spherical seal washer. When using a standard heat sink with a *Vmax-6B* new piston cylinder, do not use the spherical washer. In addition, copper glow plug washers may be needed on top of the glow plug to properly seat the heat sink against the glow plug.

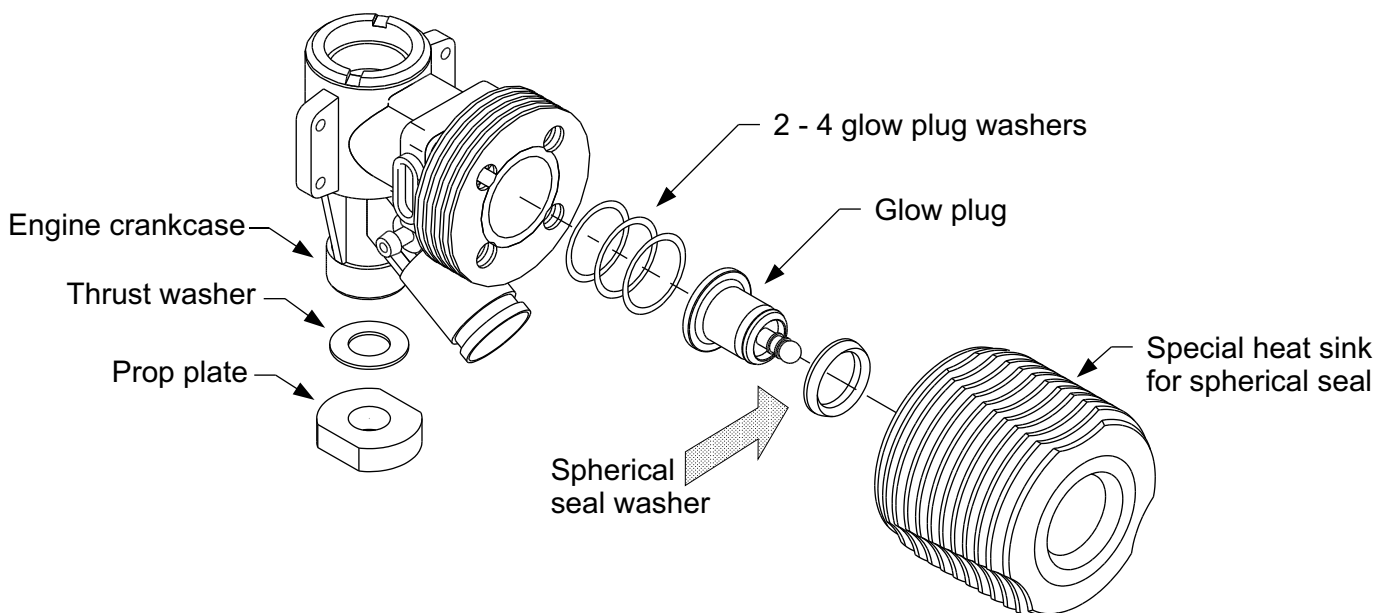

Note: Make sure to install the steel thrust washer between the engine crankcase and prop plate when assembling a *Vmax* engine and clutch.