

# HEAD LOCK AND STANDARD

## DUAL RATE GYRO

### NOTE

When the gyro is ready, the rudder servo may run to one direction. (when the gyro is in head lock mode) This phenomenon is NORMAL.

The unit is sold as is. No modification service will be provided.

### INSTALLING THE GYRO

Tape the Gyro down using the supplied foam tape. Make sure the gyro is on a solid platform, and in a well ventilated area, away from exhaust and or heat.

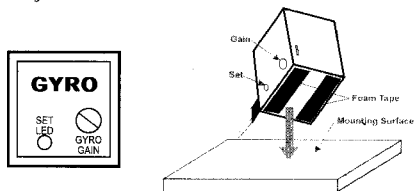

### CABLE CONNECTIONS FOR GYRO

Simply connects the Gyro in series between receiver and servo.

### Single Mode Connections :

(ONLY Support "Headlock Mode" when single mode connection is established.)

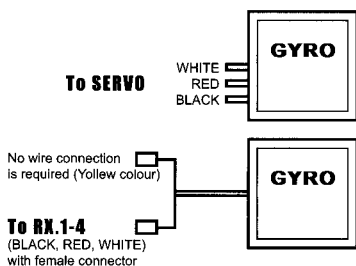

Step 1: Connect the rudder servo to the "SERVO" connection at the gyro. An extension may be necessary.

Step 2: For Futaba PPM/PCM Radio Transmitter: Connect the cable from "RX-1-4" of the gyro to the "Channel 4" of the Receiver.  
For JR PPM/SPCM/ZPCM Radio Transmitter: Connect the cable from "RX-1-4" of the gyro to the "RUDD" of the Receiver.

### Table of Connections :

		RX-1-4 connect to receiver's
Radio Transmitter	JR PPM/SPCM	"RUDD"
Radio Transmitter	Futaba PPM/PCM	Channel 4
Radio Transmitter	JR ZPCM	"RUDD"

### Dual Mode Connections :

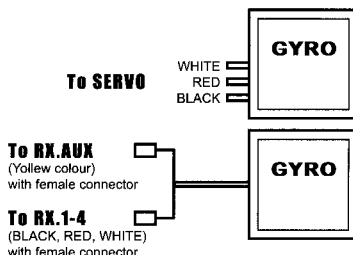

Step 1: Connect the rudder servo to the "SERVO" connection at the gyro. An extension may be necessary.

Step 2: For Futaba PPM/PCM Radio Transmitter: Connect the cable from "RX-1-4" of the gyro to the "Channel 4" of the Receiver.

For JR PPM/SPCM/ZPCM Radio Transmitter: Connect the cable from "RX-1-4" of the gyro to the "RUDD" of the Receiver.

Step 3: For Futaba PPM/PCM Radio Transmitter: Connect the cable from "RX-AUX" of the gyro to "CHANNEL 5" of the receiver.

For JR PPM/SPCM Radio Transmitter: Connect the cable from "RX-AUX" of the gyro to "AUX2" or "AUX3" + \*\* of the receiver.

For JR ZPCM Radio Transmitter: Connect the cable from "RX-AUX" of the gyro to "AUX2" + \*\* of the receiver.

### Table of Connections :

		RX-1-4 connect to receiver's	RX-AUX connect to receiver's
Radio Transmitter	JR PPM/SPCM	"RUDD"	"AUX 2" or "AUX 3"+**
Radio Transmitter	Futaba PPM/PCM	Channel 4	Channel 5
Radio Transmitter	JR ZPCM	"RUDD"	"AUX 2"+**

### JR TYPE

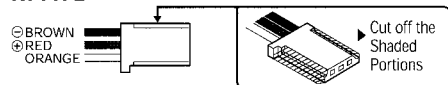

## SETTING UP

1. Switch on your transmitter.
2. Switch on your helicopter's receiver and DO NOT move the helicopter body until the LED on the gyro lights up. (It takes few seconds to light up.)
3. Set up your transmitter

Set **OFF** for the following functions (if there is any) of your transmitter:

- ATS (Automatic tail stabilization)
- Pilot authority mixing
- Throttle to rudder mixing
- Rudder to gyro mixing
- Pitch to rudder mixing
- Revolution mixing

4. Set the direction switch A ↔ B on the gyro to make tail pitch move to the right compensation.
5. Gain Control

**Single mode** : Adjust the gain control – ↔ + on the gyro (by using the small screwdriver to tune the rotary switch), to obtain maximum performance.

**Dual mode** : Adjust the gain control on transmitter Gyro gain channel of ATV to obtain maximum performance.

## TRIM ADJUSTMENT OF RUDDER BEFORE FLYING

In order for the gyro to function properly, it is utmost importance to trim the gyro properly.

1. Set the rudder trim (and sub-trim if available) to neutral.
2. Identify the gyro gain switch position on your transmitter which gives the standard gain mode and the head-lock mode. This can be done by observing the rudder servo behavior by applying full rudder command followed by release: in the standard gain mode, the rudder servo will return rapidly to the neutral position when the rudder stick is released, whereas in the head-lock mode, the rudder servo will tend to remain at its full travel limit. (Single mode connection ignore this step)
3. Set the gyro gain switch to the head-lock mode: you will find that the **RUDDER SERVO WILL CREEP IN ONE DIRECTION**.
4. Set the rudder trim (or preferably the sub-trim) so that the creep in the rudder servo is minimized. You will find that there will still be some slow residual creeping which is normal. This slow residual creeping will take 10 to 20 seconds for the rudder serve to full travel.
5. Once this trim position has been found, no further adjustment should be needed. However, some slight adjustment of the tail control linkages may still be needed in order to reduce any offset effects in the standard gain mode. (This could only be done through flight trials).
6. Select the head-lock mode and hover the helicopter.
7. Applying short stabs to the rudder control and see whether there is any tendency for the tail to oscillate. Reduce the gyro gain if oscillation is seen. Conversely, increase the gain if no oscillation is seen. (The aim of to use the highest possible gain without introducing oscillation)

8. Observe, any trim offset in the tail and correct with the rudder trim.
9. Select the standard gain mode and repeat the exercise. In this case, any offset effects should be corrected by adjusting the tail rotor linkages.

## IMPORTANT :

1. If after adjusting the gyro gain with the transmitter and tail is still hunting slightly move the control link to a different position on the rudder servo disk (the extreme outside fourth position is recommended)

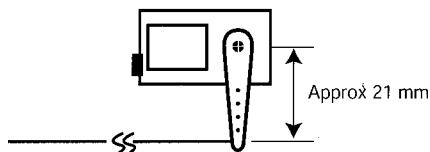

2. In order to let the gyro adapt to the temperature and humidity of the flying field, it is strongly recommended to leave the gyro and receiver in ON position for at least 5 minutes, then switch on/off to reset the receiver afterward.

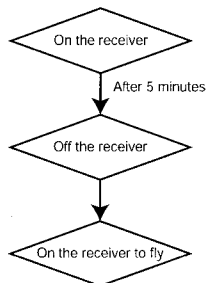

## Cautions :

This device is not a toy.

Safety is the top priority.

We do not assume any liability for consequential damages as result of the product use, and in any event, our liability shall not exceed the original price of the device unit.

\* ALL BRAND NAMES AND TRADEMARKS ARE THE PROPERTY OF RESPECTIVE OWNERS

\* SPECIFICATIONS SUBJECT TO CHANGE WITHOUT NOTICE.

# RECOMMENDED RADIO TRANSMITTER SETTINGS

SET INHIBIT	TAIL ROTOR, PILOT AUTHORITY MIXING SYSTEMS, REVOLUTION, GYRO SENSE, TAIL MIXING
GAIN CHANNEL	CHANNEL 5
GAIN SWITCH	CHANNEL 5
ATV VALUE (RUDDER CHANNEL)	50% (BOTH DIRECTION)
ATV VALUE (GYRO GAIN CHANNEL)	50% (BOTH STANDARD AND HEAD LOCK MODE)
RUDDER TRIM	SUB - TRIM

## Use of Adhesive Foam during Gyro Installation

Vibration can do a lot of damage to a gyro, therefore it is important to mount the gyro to a surface where there is little vibration. It is also important to increase damping to the gyro, in order to decrease vibrations. For the best result, please follow these instructions for mounting the gyro using adhesive foam.

When installing the gyro, follow the steps regarding the use of adhesive foam below:

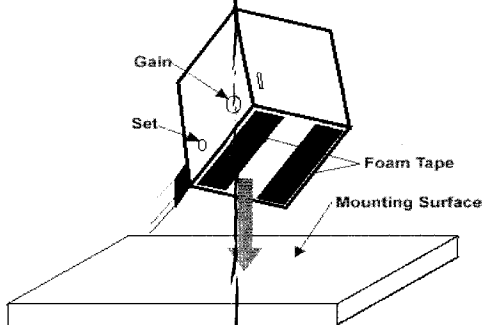

1. Find a position at or near the centre of mass of the R/C helicopter where there should be little vibration.
2. Clean the mounting surface and the bottom surface of the gyro using alcohol.
3. Using the two pieces of adhesive foam provided, attach one piece at each end of the bottom surface of the gyro, then adhere the gyro onto the mounting surface. Do not use one large piece of adhesive foam that covers the whole bottom of the gyro.

**IMPORTANT:** Do not use double-sided tape without foam padding.

It is important to replace the adhesive foam when it starts to become less adhesive, worn down, loose, etc. It is recommended that you use adhesive foam that is 3mm thick. An example of an adhesive foam which can be used is Telefoam, product no. 301. When removing the gyro to replace the adhesive tape, lever the gyro off the mounting surface such as a flat-head screwdriver, etc.